

CKG57NX7S2A226M500JJ

TDK item description : CKG57NX7S2A226MT***



Application & Main Feature

Automotive grade (MEGACAP)

Series

CKG57N(5750) [EIA 2220]

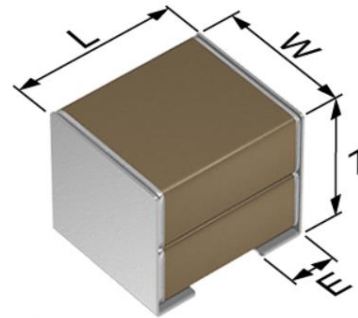

Dimensions

L 6.00±0.50 mm
W 5.00±0.50 mm
T 5.00±0.50 mm
E 1.60±0.30 mm

Temperature Characteristic

X7S (-55 to +125 degC, ±22%)

Rated Voltage

2A (100Vdc)

Capacitance

22µF

Capacitance Tolerance

M (±20%)

DF

5 % max.

Insulation Resistance

22 Mohm min.

AEC-Q200

Yes

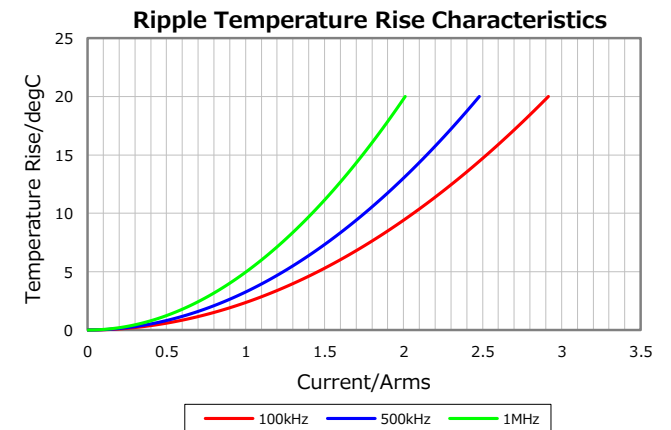
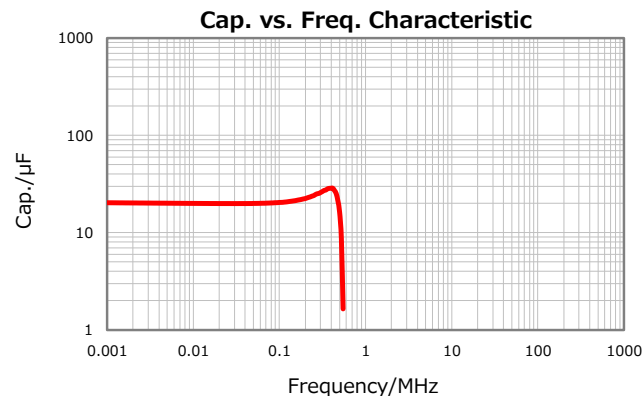
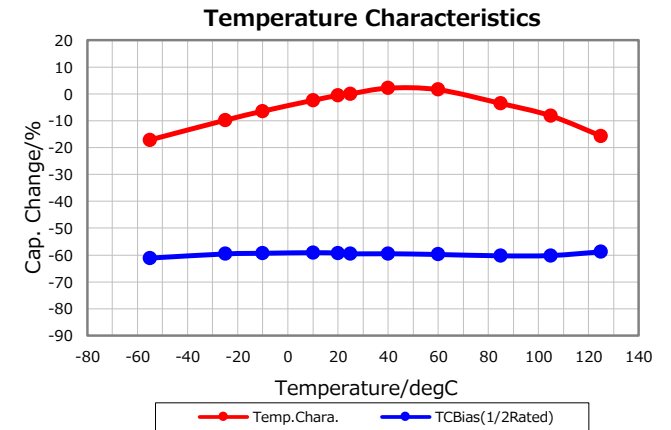
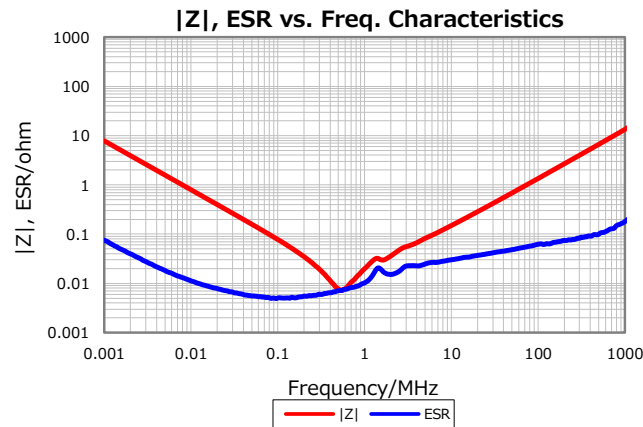
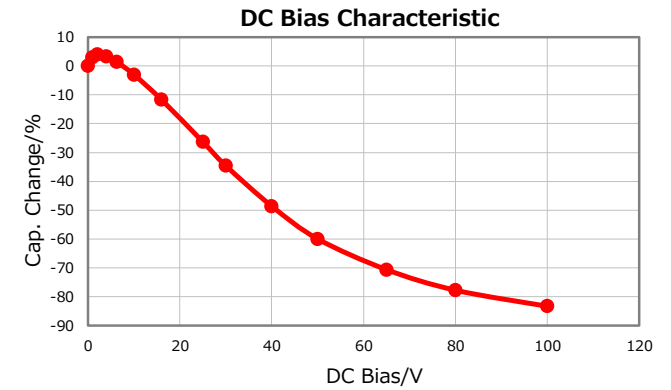

Characterization Sheet (Multilayer Ceramic Chip Capacitors)



⚠ All specifications are subject to change without notice.

March 19, 2022