

LQH3NPN101NG0#

"#" indicates a package specification code.

Size Code 3030 (1212) in mm (in inch), 1.0mm max. Thickness



< List of part numbers with package codes >
LQH3NPN101NG0K LQH3NPN101NG0L

Appearance & Shape

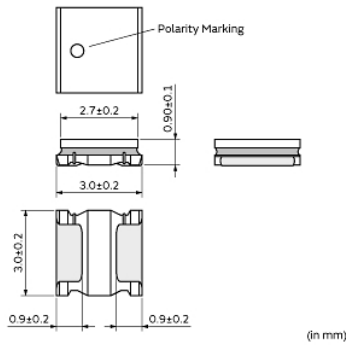
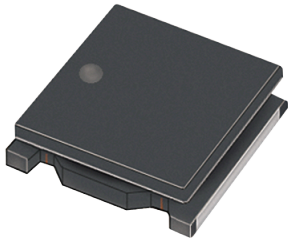

References

Packaging	Specifications	Standard Packing Quantity
K	330Embossed Tape	6000
L	180Embossed Tape	1500

Mass (typ.)	
1 piece	0.034g

Notices

When rated current is applied to the products, inductance will be within $\pm 30\%$ of nominal inductance value. When rated current is applied to the products, the temperature rise caused by self-generated heat shall be limited to 40°C max. Keep the temperature (ambient temperature plus self-generation of heat) under 125°C.

Attention

- 1.This datasheet is downloaded from the website of Murata Manufacturing Co., Ltd. Therefore, it's specifications are subject to change or our products in it may be discontinued without advance notice. Please check with our sales representatives or product engineers before ordering.
- 2.This datasheet has only typical specifications because there is no space for detailed specifications. Therefore, please review our product specifications or consult the approval sheet for product specifications before ordering.

LQH3NPN101NG0#

“#” indicates a package specification code.



Specifications

L size	3.0±0.2mm
W size	3.0±0.2mm
T size	0.9±0.1mm
Size code inch (mm)	1212 (3030)
Inductance	100µH±30%
Inductance Test Frequency	1MHz
Rated current (Isat) (Based on Inductance change)	140mA
Rated current (Itemp) (Based on Temperature rise)	165mA
Max. of DC resistance	9.6Ω
Class of magnetic shield	Magnetic Resin
Self resonance frequency (min.)	10MHz
Operating Temperature Range(Self-temperature rise is not included)	-40°C to 85°C
Brand	Murata
DC Resistance Intermediate Values	8.0Ω±20%
Series	LQH3NPN_G0

Attention

- 1.This datasheet is downloaded from the website of Murata Manufacturing Co., Ltd. Therefore, it's specifications are subject to change or our products in it may be discontinued without advance notice. Please check with our sales representatives or product engineers before ordering.
- 2.This datasheet has only typical specifications because there is no space for detailed specifications. Therefore, please review our product specifications or consult the approval sheet for product specifications before ordering.

LQH3NPN101NG0#

"#" indicates a package specification code.

Characteristic Data

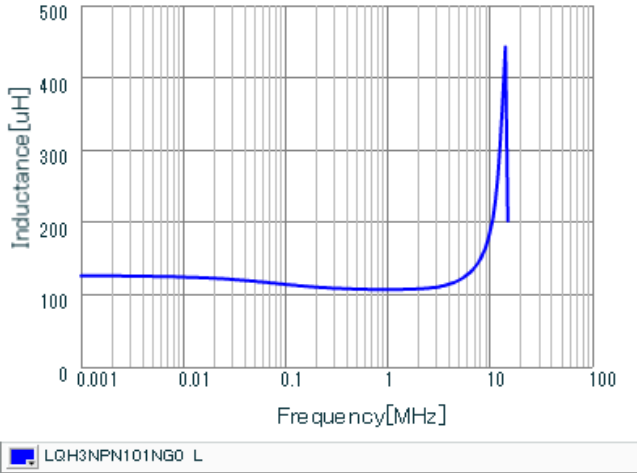

Inductance - Frequency Characteristics

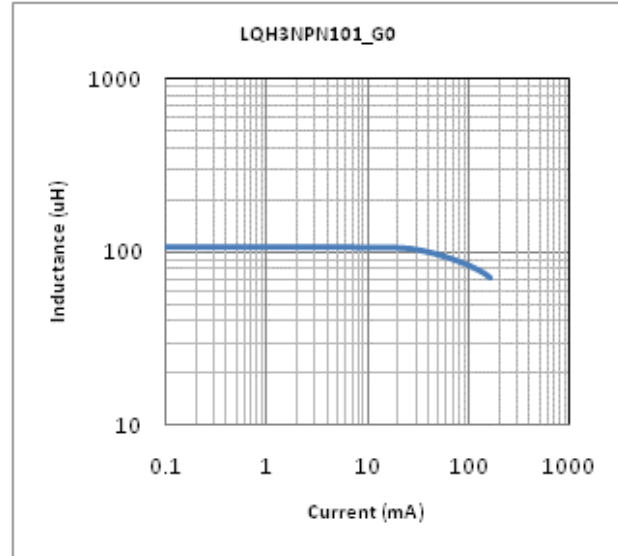

Impedance - Current Characteristics

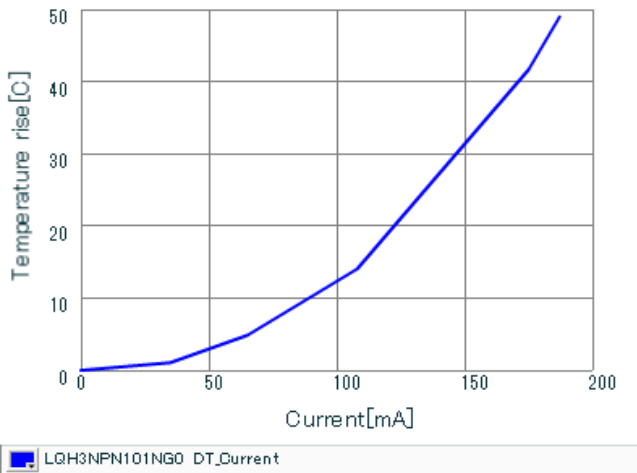

Temperature Increase Characteristic

Attention

- 1.This datasheet is downloaded from the website of Murata Manufacturing Co., Ltd. Therefore, it's specifications are subject to change or our products in it may be discontinued without advance notice. Please check with our sales representatives or product engineers before ordering.
- 2.This datasheet has only typical specifications because there is no space for detailed specifications. Therefore, please review our product specifications or consult the approval sheet for product specifications before ordering.