

FEATURES

- 50 Mbps to 1.25 Gbps operation**
- Single 3.3 V operation**
- Bias current range: 2 to 100 mA**
- Modulation current range: 5 to 80 mA**
- Monitor photo diode current: 50 μ A to 1200 μ A**
- 50 mA supply current at 3.3 V**
- Closed-loop control of power and extinction ratio**
- Full current parameter monitoring**
- Laser fail and laser degrade alarms**
- Automatic laser shutdown (ALS)**
- Optional clocked data**
- Supports FEC rates**
- 32-lead, 5 mm \times 5 mm LFCSP_VQ package**

APPLICATIONS

- SONET OC-1/3/12/24**
- SDH STM-0/1/4**
- Fibre Channel**
- Gigabit Ethernet**

GENERAL DESCRIPTION

The ADN2848 uses a unique control algorithm to control both the average power and the extinction ratio of the laser diode (LD) after initial factory setup. External component count and PCB area are low because both power and extinction ratio control are fully integrated. Programmable alarms are provided for laser fail (end of life) and laser degrade (impending fail).

FUNCTIONAL BLOCK DIAGRAM

Figure 1.

Rev. B

[Document Feedback](#)

Information furnished by Analog Devices is believed to be accurate and reliable. However, no responsibility is assumed by Analog Devices for its use, nor for any infringements of patents or other rights of third parties that may result from its use. Specifications subject to change without notice. No license is granted by implication or otherwise under any patent or patent rights of Analog Devices. Trademarks and registered trademarks are the property of their respective owners.

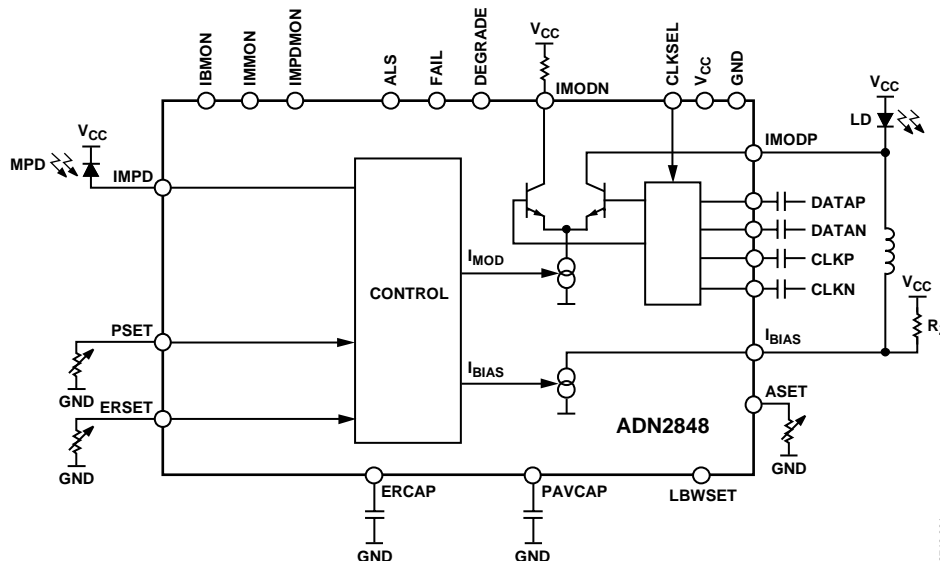
One Technology Way, P.O. Box 9106, Norwood, MA 02062-9106, U.S.A.
 Tel: 781.329.4700 ©2003–2013 Analog Devices, Inc. All rights reserved.
[Technical Support](#) www.analog.com

TABLE OF CONTENTS

Features	1	Alarms.....	7
Applications.....	1	Monitor Currents	8
General Description	1	Data and Clock Inputs	8
Functional Block Diagram	1	CCBIAS.....	8
Revision History	2	I _{BIAS}	8
Specifications.....	3	Automatic Laser Shutdown.....	8
Absolute Maximum Ratings.....	5	Alarm Interfaces	8
ESD Caution.....	5	Power Consumption	9
Pin Configuration and Function Descriptions.....	6	Laser Diode Interfacing.....	9
Theory of Operation	7	Optical Supervisor.....	9
Control.....	7	Outline Dimensions	12
Loop Bandwidth Selection	7	Ordering Guide	12

REVISION HISTORY

2/13—Rev. A to Rev. B

Added EPAD Notation.....	6
Changes to Endnote	8
Updated Outline Dimensions	12
Changes to Ordering Guide	12

8/06—Rev. 0 to Rev. A

Updated Format.....	Universal
Changes to Figure 1.....	1
Changes to Specifications	3
Changes to Figure 8.....	10
Changes to Figure 9 to Figure 11.....	11
Updated Outline Dimensions	12
Changes to Ordering Guide	12

1/03—Revision 0: Initial Version

SPECIFICATIONS

$V_{CC} = 3.0\text{ V}$ to 3.6 V . All specifications T_{MIN} to T_{MAX} , unless otherwise noted.¹ Typical values are specified at 25°C .

Table 1.

Parameter	Min	Typ	Max	Unit	Conditions/Comments
LASER BIAS Current (I_{BIAS} , ALS)					
Output Current I_{BIAS}	2		100	mA	I_{BIAS} When ALS asserted $I_{BIAS} < 10\%$ of nominal
Compliance Voltage	1.2		V_{CC}	V	
I_{BIAS}			0.1	mA	
ALS Response Time			5	μs	
CCBIAS Compliance Voltage	1.2		V_{CC}	V	
MODULATION CURRENT (I_{MODP} , I_{MODN})					
Output Current I_{MOD}	5		80	mA	When ALS asserted
Compliance Voltage	1.5		V_{CC}	V	
I_{MOD}			0.1	mA	
Rise Time ²		80	170	ps	
Fall Time ²		80	170	ps	
Random Jitter ²		1	1.5	ps	
Pulse Width Distortion ²		15		ps	
MONITOR PD (MPD)					
Current	50		1200	μA	Average current
Compliance Voltage			1.65	V	
POWER SET INPUT (PSET)					
Capacitance			80	pF	Average current
Monitor Photodiode Current into RPSET Resistor	50		1200	μA	
Voltage	1.1	1.2	1.3	V	
EXTINCTION RATIO SET INPUT (ERSET)					
Allowable Resistance Range	1.2		25	$\text{k}\Omega$	
Voltage	1.1	1.2	1.3	V	
ALARM SET (ASET)					
Allowable Resistance Range	1.2		25	$\text{k}\Omega$	
Voltage	1.1	1.2	1.3	V	
Hysteresis		5		%	
CONTROL LOOP					Low loop bandwidth selection
Time Constant		0.22		sec	LBWSET = GND
		2.25		sec	LBWSET = V_{CC}
DATA INPUTS (DATAP, DATAN, CLKP, CLKN) ³					
V p-p (Single-Ended, Peak-to-Peak)	100		500	mV	Data and clock inputs are ac-coupled See Figure 2 See Figure 2
Input Impedance (Single-Ended)		50		Ω	
t_{SETUP} ⁴	50			ps	
t_{HOLD} ⁴	100			ps	
LOGIC INPUTS (ALS, LBWSET, CLKSEL)					
V_{IH}	2.4			V	
V_{IL}			0.8	V	
ALARM OUTPUTS (FAIL, DEGRADE)					Internal 30 $\text{k}\Omega$ pull-up
V_{OH}	2.4			V	
V_{OL}			0.8	V	
IBMON, IMMON, IMPDMON					
IMMON Division Ratio		100		A/A	
IMPDMON		1		A/A	
Compliance Voltage	0		$V_{CC} - 1.2$	V	

Parameter	Min	Typ	Max	Unit	Conditions/Comments
SUPPLY					
I_{CC}^5		50		mA	$I_{BIAS} = I_{MOD} = 0$
V_{CC}^6	3.0	3.3	3.6	V	

¹ Temperature range is -40°C to $+85^{\circ}\text{C}$.

² Measured into a $25\ \Omega$ load using a 0-1 pattern at 622 Mbps.

³ When the voltage on DATAP is greater than the voltage on DATAN, the modulation current flows in the IMODP pin.

⁴ Guaranteed by design and characterization. Not production tested.

⁵ I_{CCMIN} for power calculation on Page 9 is the typical I_{CC} given.

⁶ All V_{CC} pins should be shorted together.

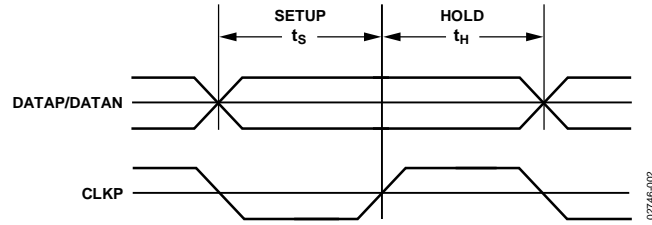

Figure 2. Setup and Hold Time

02746-002

ABSOLUTE MAXIMUM RATINGS

Table 2.

Parameter	Rating
V _{CC} to GND	4.2 V
Digital Inputs (ALS, LBWSET, CLKSEL)	-0.3 V to V _{CC} + 0.3 V
IMODN, IMODP	V _{CC} + 1.2 V
Operating Temperature Range	
Industrial	-40°C to +85°C
Storage Temperature Range	-65°C to +150°C
Junction Temperature (T _J Max)	150°C
32-Lead LFCSP_VQ Package	
Power Dissipation ¹	(T _J Max - T _A)/θ _{JA} W
θ _{JA} Thermal Impedance ²	32°C/W
Lead Temperature (Soldering for 10 sec)	300°C

¹ Power consumption formulas are provided on Page 9.

² θ_{JA} is defined when device is soldered in a 4-layer board.

Stresses above those listed under Absolute Maximum Ratings may cause permanent damage to the device. This is a stress rating only; functional operation of the device at these or any other conditions above those indicated in the operational section of this specification is not implied. Exposure to absolute maximum rating conditions for extended periods may affect device reliability.

ESD CAUTION



ESD (electrostatic discharge) sensitive device. Charged devices and circuit boards can discharge without detection. Although this product features patented or proprietary protection circuitry, damage may occur on devices subjected to high energy ESD. Therefore, proper ESD precautions should be taken to avoid performance degradation or loss of functionality.

PIN CONFIGURATION AND FUNCTION DESCRIPTIONS

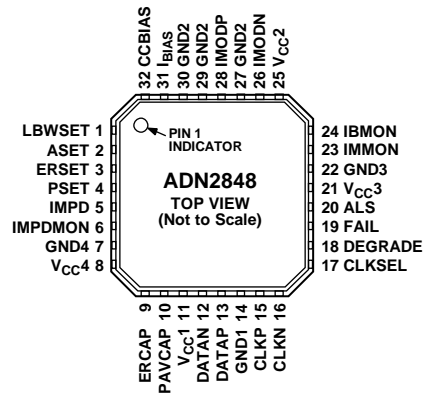

NOTES

1. THE EXPOSED PAD ON THE BOTTOM OF THE PACKAGE MUST BE CONNECTED TO THE DEVICE GND.

02746-003

Figure 3. Pin Configuration

Table 3. Pin Function Descriptions

Pin No.	Mnemonic	Description
1	LBWSET	Loop Bandwidth Select.
2	ASET	Alarm Threshold Set Pin.
3	ERSET	Extinction Ratio Set Pin.
4	PSET	Average Optical Power Set Pin.
5	IMPD	Monitor Photodiode Input.
6	IMPDMON	Mirrored Current from Monitor Photodiode—Current Source.
7	GND4	Supply Ground.
8	V _{CC4}	Supply Voltage.
9	ERCAP	Extinction Ratio Loop Capacitor.
10	PAVCAP	Average Power Loop Capacitor.
11	V _{CC1}	Supply Voltage.
12	DATAN	Data Negative Differential Terminal.
13	DATAP	Data Positive Differential Terminal.
14	GND1	Supply Ground.
15	CLKP	Data Clock Positive Differential Terminal. This pin is used if CLKSEL = V _{CC} .
16	CLKN	Data Clock Negative Differential Terminal. This pin is used if CLKSEL = V _{CC} .
17	CLKSEL	Clock Select (Active = V _{CC}). This pin is used if data is clocked into chip.
18	DEGRADE	DEGRADE Alarm Output.
19	FAIL	FAIL Alarm Output.
20	ALS	Automatic Laser Shutdown.
21	V _{CC3}	Supply Voltage.
22	GND3	Supply Ground.
23	IMMON	Modulation Current Mirror Output—Current Source.
24	IBMON	Bias Current Mirror Output—Current Source.
25	V _{CC2}	Supply Voltage.
26	IMODN	Modulation Current Negative Output. Connect this pin via a matching resistor to V _{CC} .
27	GND2	Supply Ground.
28	IMODP	Modulation Current Positive Output. Connect this pin to the laser diode.
29, 30	GND2	Supply Ground.
31	I _{BIAS}	Laser Diode Bias Current—Current Sink.
32	CCBIAS	Connected to V _{CC} When DC-Coupled to Laser Diode; Connected to I _{BIAS} When AC-Coupled to Laser Diode—Current Sink.
EP	EPAD	Exposed Pad. The exposed pad on the bottom of the package must be connected to the device GND.

THEORY OF OPERATION

A laser diode (LD) has current-in to light-out transfer functions, as shown in Figure 4. Two key characteristics of this transfer function are the threshold current, I_{TH} , and slope in the linear region beyond the threshold current, referred to as slope efficiency, or LI.

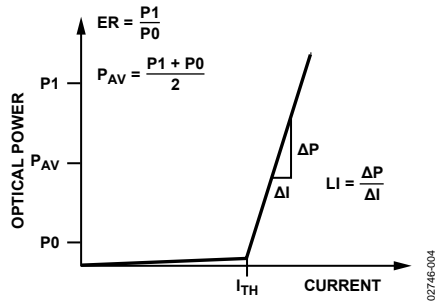

Figure 4. Laser Transfer Function

CONTROL

A monitor photodiode, MPD, is required to control the LD. The MPD current is fed into the ADN2848 to control the power and extinction ratio, continuously adjusting the bias current and modulation current in response to the laser's changing threshold current and light-to-current slope efficiency.

The ADN2848 uses automatic power control, APC, to maintain a constant average power over time and temperature.

The ADN2848 uses closed-loop extinction ratio control to allow optimum setting of extinction ratio for every device. Thus, SONET/SDH interface standards can be met over device variation, temperature, and laser aging. Closed-loop modulation control eliminates the need to either overmodulate the LD or include external components for temperature compensation. This reduces research and development time and second sourcing issues caused by characterizing LDs.

Average power and extinction ratio are set using the PSET and ERSET pins, respectively. Potentiometers are connected between these pins and ground. The potentiometer R_{PSET} is used to change the average power. The potentiometer R_{ERSET} is used to adjust the extinction ratio. Both PSET and ERSET are kept 1.2 V above GND.

For an initial setup, R_{PSET} and R_{ERSET} potentiometers can be calculated using the following formulas:

$$R_{PSET} = \frac{1.2 \text{ V}}{I_{AV}} (\Omega)$$

$$R_{ERSET} = \frac{1.2 \text{ V}}{\frac{I_{MPD_CW}}{P_{CW}} \times \frac{ER - 1}{ER + 1} \times P_{AV}} (\Omega)$$

where:

I_{AV} is the average MPD current.

P_{CW} is the dc optical power specified on the laser data sheet.

I_{MPD_CW} is the MPD current at that specified P_{CW} .

P_{AV} is the average power required.

ER is the desired extinction ratio ($ER = P_1/P_0$).

Note that I_{ERSET} and I_{PSET} change from device to device; however, the control loops determine the actual values. It is not required to know the exact values for LI or MPD optical coupling.

LOOP BANDWIDTH SELECTION

For continuous operation, the user hardwires the LBWSET pin high and uses 1 μF capacitors to set the actual loop bandwidth. These capacitors are placed between the PAVCAP and ERCAP pins and ground. It is important that these capacitors are low leakage multilayer ceramics with an insulation resistance greater than 100 G Ω or a time constant of 1000 seconds, whichever is less.

Setting LBSET low and using 47 nF capacitors results in a shorter loop time constant (a 10 \times reduction over using 1 μF capacitors and keeping LBWSET high).

Table 4.

Operation Mode	LBWSET	Recommended PAVCAP	Recommended ERCAP
Continuous 50 Mbps to 1.25 Gbps	High	1 μF	1 μF
Optimized for 1.25 Gbps	Low	47 nF	47 nF

ALARMS

The ADN2848 is designed to allow interface compliance to ITU-T-G958 (11/94), section 10.3.1.1.2 (transmitter fail) and section 10.3.1.1.3 (transmitter degrade). The ADN2848 has two active high alarms, DEGRADE and FAIL. A resistor between ground and the ASET pin is used to set the current at which these alarms are raised. The current through the ASET resistor is a ratio of 100:1 to the FAIL alarm threshold. The DEGRADE alarm is raised at 90% of this level.

Example:

$$I_{FAIL} = 50 \text{ mA so } I_{DEGRADE} = 45 \text{ mA}$$

$$I_{ASET} = \frac{I_{FAIL}}{100} = \frac{50 \text{ mA}}{100} = 500 \mu\text{A}$$

$$R_{ASET}^* = \frac{1.2 \text{ V}}{I_{ASET}} = \frac{1.2}{500 \mu\text{A}} = 2.4 \text{ k}\Omega$$

*The smallest valid value for R_{ASET} is 1.2 k Ω , because this corresponds to the maximum I_{BIAS} of 100 mA.

The laser degrade alarm, DEGRADE, is provided to give a warning of imminent laser failure if the laser diode degrades further or if environmental conditions such as increasing temperature continue to stress the LD.

The laser fail alarm, FAIL, is activated when the transmitter can no longer be guaranteed to be SONET/SDH compliant. This occurs when one of the following conditions arise:

- The ASET threshold is reached.
- The ALS pin is set high. This shuts off the modulation and bias currents to the LD, resulting in the MPD current dropping to zero. This gives closed-loop feedback to the system that ALS has been enabled.

DEGRADE is raised only when the bias current exceeds 90% of ASET current.

MONITOR CURRENTS

IBMON, IMMON, and IMPDMON are current controlled current sources from V_{CC} . They mirror the bias, modulation, and MPD current for increased monitoring functionality. An external resistor to GND gives a voltage proportional to the current monitored.

If the monitoring function IMPDMON is not required, the IMPD pin must be grounded and the monitor photodiode output must be connected directly to the PSET pin.

DATA AND CLOCK INPUTS

Data and clock inputs are ac-coupled (10 nF capacitors recommended) and terminated via a 100 Ω internal resistor between DATAP and DATAN and also between the CLKP and CLKN pins. There is a high impedance circuit to set the common-mode voltage, which is designed to allow for maximum input voltage headroom over temperature. It is necessary that ac coupling be used to eliminate the need for matching between common-mode voltages.

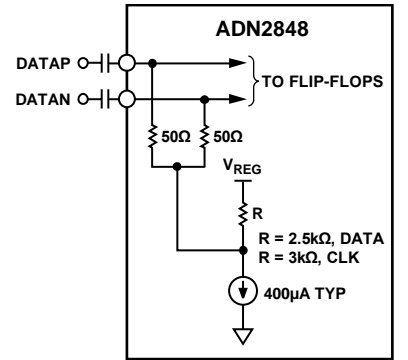

Figure 5. AC Coupling of Data Inputs

For input signals that exceed 500 mV p-p single-ended, it is necessary to insert an attenuation circuit as shown in Figure 6.

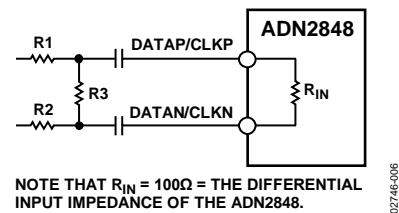

Figure 6. Attenuation Circuit

CCBIAS

When the laser is used in ac-coupled mode, the CCBIAS pin and the I_{BIAS} pin are tied together (see Figure 9). In dc-coupled mode, CCBIAS is tied to V_{CC} .

I_{BIAS}

To achieve optimum optical eye quality, a pull-up resistor R_Z , as shown in Figure 8 and Figure 9, is required. The recommended R_Z value is approximately 200 Ω ~ 500 Ω .

AUTOMATIC LASER SHUTDOWN

The ADN2848 ALS allows compliance to ITU-T-G958 (11/94), section 9.7. When ALS is logic high, both the bias and the modulation currents are turned off. Correct operation of ALS is confirmed by the FAIL alarm being raised when ALS is asserted. Note that this is the only time that DEGRADE is low while FAIL is high.

ALARM INTERFACES

The FAIL and DEGRADE outputs have an internal 30 k Ω pull-up resistor that is used to pull the digital high value to V_{CC} . However, the alarm output can be overdriven with an external resistor, allowing alarm interfacing to non- V_{CC} levels. **Non- V_{CC} alarm output levels must be below the V_{CC} used for the ADN2848.**

POWER CONSUMPTION

The ADN2848 die temperature must be kept below 125°C. The LFCSP_VQ package has an exposed paddle. The exposed paddle should be connected in such a manner that it is at the same potential as the ADN2848 ground pins. The θ_{JA} for the package is shown under the Absolute Maximum Ratings. Power consumption can be calculated using

$$I_{CC} = I_{CCMIN} + 0.3 I_{MOD}$$

$$P = V_{CC} \times I_{CC} + (I_{BIAS} \times V_{BIAS_PIN}) + I_{MOD} (V_{MODP_PIN} + V_{MODN_PIN})/2$$

$$T_{DIE} = T_{AMBIENT} + \theta_{JA} \times P$$

Thus, the maximum combination of $I_{BIAS} + I_{MOD}$ must be calculated

where:

$I_{CCMIN} = 50$ mA, the typical value of I_{CC} provided on Page 3 with $I_{BIAS} = I_{MOD} = 0$.

T_{DIE} = die temperature.

$T_{AMBIENT}$ = ambient temperature.

V_{BIAS_PIN} = voltage at I_{BIAS} pin.

V_{MODP_PIN} = average voltage at I_{MODP} pin.

V_{MODN_PIN} = average voltage at I_{MODN} pin.

LASER DIODE INTERFACING

Many laser diodes designed for 1.25 Gbps operation are packaged with an internal resistor to bring the effective impedance up to 25 Ω in order to minimize transmission line effects. In high current applications, the voltage drop across this resistor, combined with the laser diode forward voltage, makes direct connection between the laser and the driver impractical in a 3 V system. AC coupling the driver to the laser diode removes this headroom constraint.

Caution must be used when choosing component values for ac coupling to ensure that the time constants (L/R and RC , see Figure 9) are sufficiently long for the data rate and the expected number of CIDs (consecutive identical digits). Failure to do this could lead to pattern dependent jitter and vertical eye closure. For designs with low series resistance, or where external components become impractical, the ADN2848 supports direct connection to the laser diode (see Figure 8). In this case, care must be taken to ensure that the voltage drop across the laser diode does not violate the minimum compliance voltage on the I_{MODP} pin.

OPTICAL SUPERVISOR

The PSET and ERSET potentiometers can be replaced with a dual digital potentiometer, the ADN2850 (see Figure 7). The ADN2850 provides an accurate digital control for the average optical power and extinction ratio and ensures excellent stability over temperature.

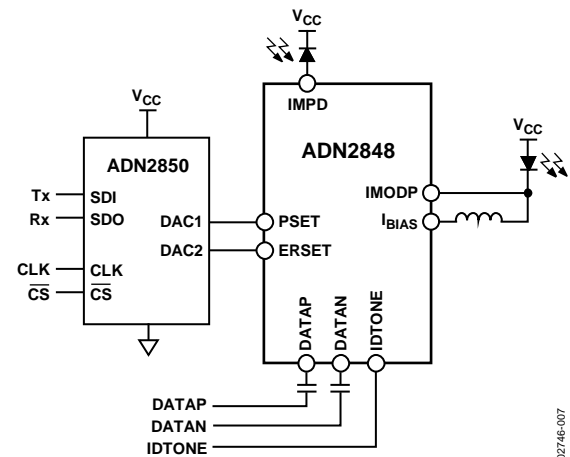
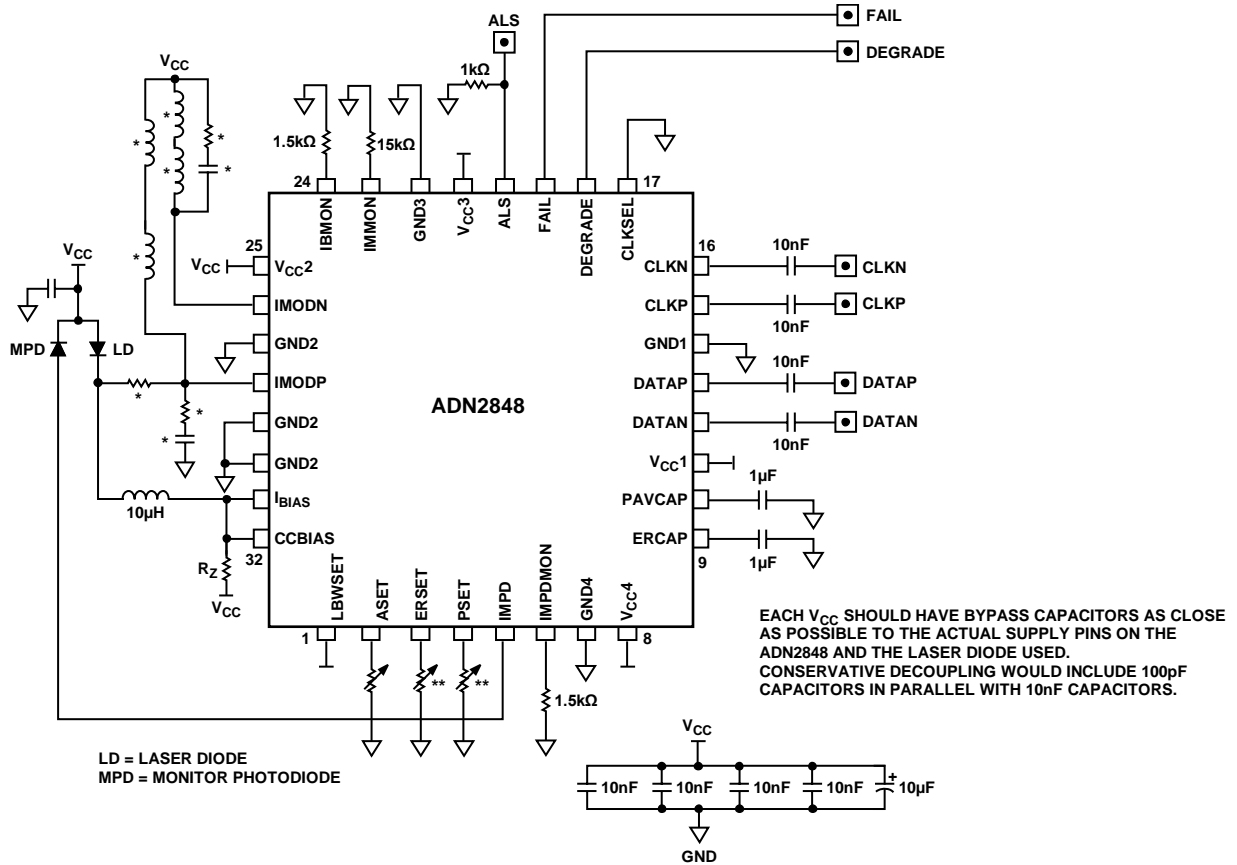

Figure 7. Application Using the ADN2850 Dual 10-Bit Digital Potentiometer with Extremely Low Temperature Coefficient as an Optical Supervisor



NOTES
 * DESIGNATES COMPONENTS THAT NEED TO BE OPTIMIZED FOR THE TYPE OF LASER USED.
 **FOR DIGITAL PROGRAMMING. THE ADN2850 OR THE ADN2860 OPTICAL SUPERVISOR CAN BE USED.

Figure 9. AC-Coupled 50 Mbps to 1.25 Gbps Test Circuit, Data Not Clocked

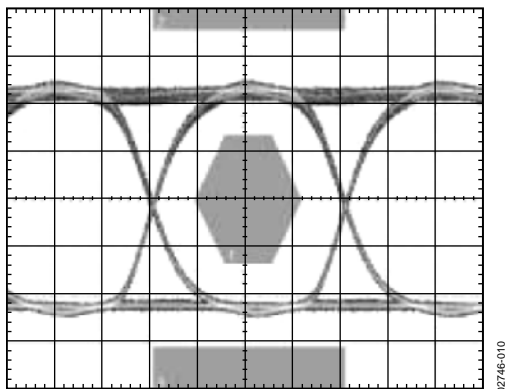

Figure 10. A 1.244 Mbps Optical Eye. Temperature at 25°C. Average Power = 0 dBm, Extinction Ratio = 10 dB, PRBS 31 Pattern, 1 Gb Ethernet Mask. Eye Obtained Using a DFB Laser.

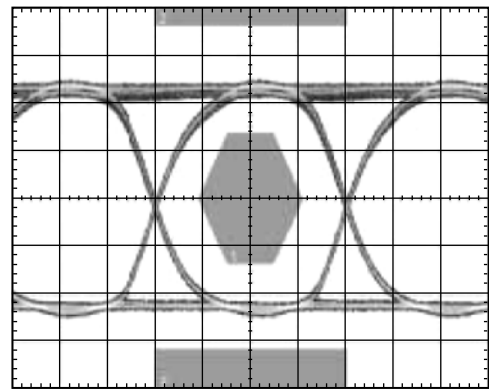
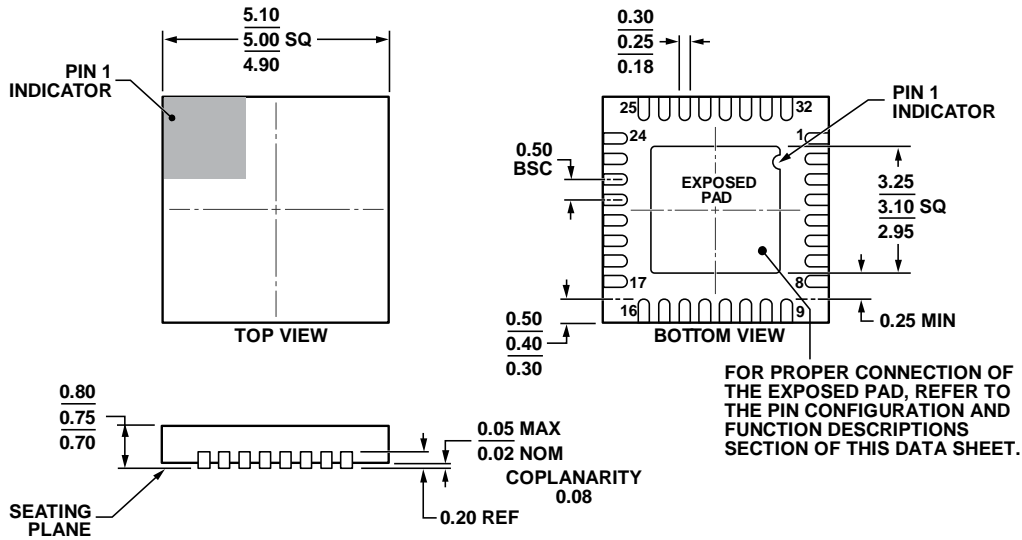

Figure 11. A 1.244 Mbps Optical Eye. Temperature at 85°C. Average Power = 0 dBm, Extinction Ratio = 10 dB, PRBS 31 Pattern, 1 Gb Ethernet Mask. Eye Obtained Using a DFB Laser.

OUTLINE DIMENSIONS



COMPLIANT TO JEDEC STANDARDS MO-220-WHHD.

Figure 12. 32-Lead Lead Frame Chip Scale Package [LFCSP_WQ]
 5 mm × 5 mm Body, Very Very Thin Quad
 (CP-32-7)
 Dimensions shown in millimeters

112408-A

ORDERING GUIDE

Model ¹	Temperature Range	Package Description	Package Option
ADN2848ACPZ-32	-40°C to +85°C	32-Lead LFCSP_WQ	CP-32-7
ADN2848ACPZ-32-RL	-40°C to +85°C	32-Lead LFCSP_WQ	CP-32-7
ADN2848ACPZ-32-RL7	-40°C to +85°C	32-Lead LFCSP_WQ	CP-32-7

¹ Z = RoHS Compliant Part.