

CGA8M1X7R3A103K200KA

TDK Item Description : CGA8M1X7R3A103KT****



Equivalent C4532X7R3A103K for Automotive

Application & Main Feature

Automotive Grade (High Voltage (1000V and over))

Series

CGA8(4532) [EIA CC1812]

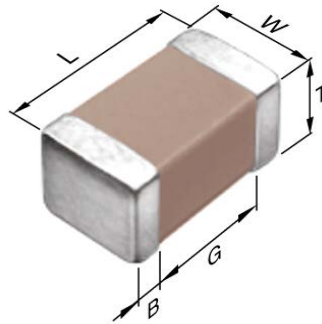

Dimensions

L 4.50mm +/-0.4mm
 W 3.20mm +/-0.4mm
 T 2.00mm +/-0.2mm
 B 0.20mm Min.
 G

Temperature Characteristic

X7R (-55 to 125 degC +/-15%)

Rated Voltage

3A (1000Vdc)

Capacitance

10nF

Capacitance Tolerance

K (+/-10%)

Dissipation Factor

3% Max.

Insulation Resistance

10Gohm Min.

AEC-Q200

Yes

DC Bias Characteristic

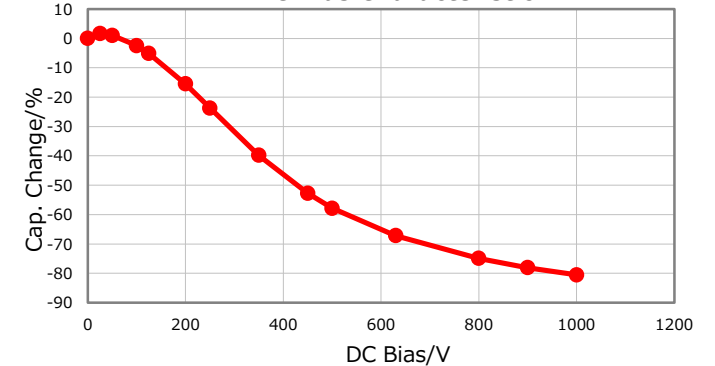

|Z|, ESR vs. Freq. Characteristics

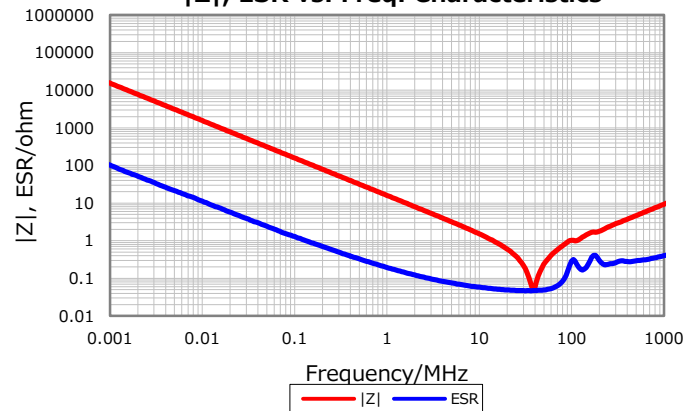

Temperature Characteristics

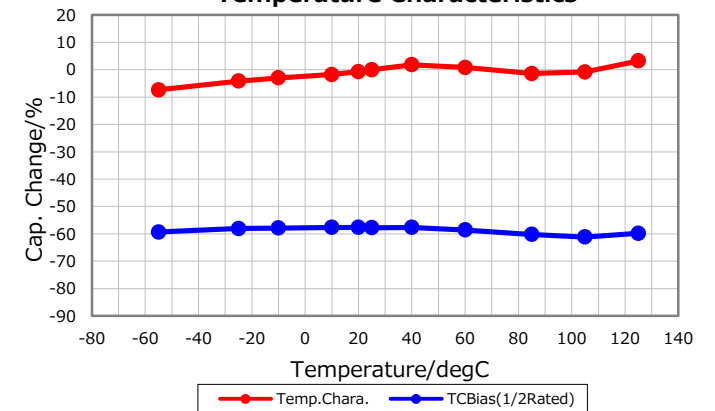

Cap. vs. Freq. Characteristic

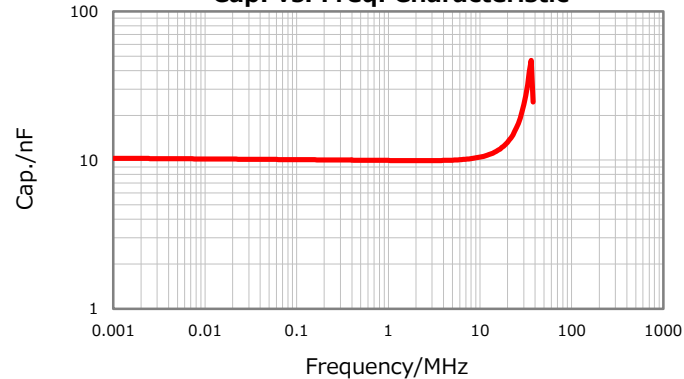

Ripple Temperature Rise Characteristics

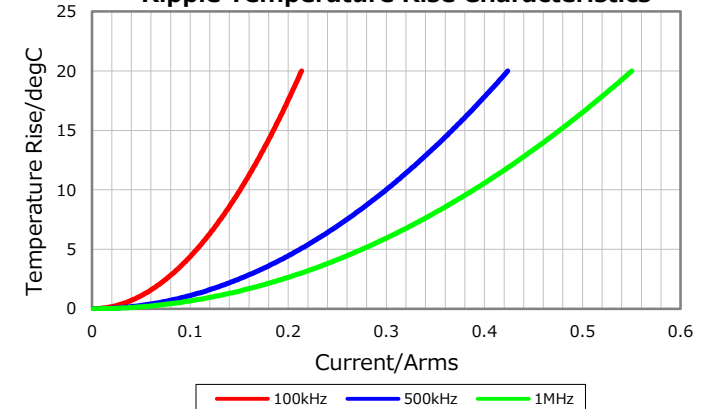

Characterization Sheet (Multilayer Ceramic Chip Capacitors)



All specifications are subject to change without notice.

March 23, 2018