

ADXL202EB

GENERAL DESCRIPTION

The ADXL202EB is a simple evaluation board that allows the user to quickly evaluate the performance of the ADXL202 dual axis $\pm 2 g$ accelerometer. Only three additional through-hole passive components must be added, depending on the bandwidth required in your application. The ADXL202EB has a 5-pin 0.1 inch spaced header for access to all power and signal lines that may be attached to a prototyping board (breadboard) or wired via a standard plug. Two holes are provided for mechanical attachment of the ADXL202EB to applications.

CIRCUIT DESCRIPTION

The ADXL202EB schematic and parts list are shown in Figure 1 and Table I, respectively. The minimal application will require at least one resistor (R_{SET}) added to the board to set the PWM period (T_2). Analog bandwidth may be set by adding capacitors C2 and C3. Refer to the ADXL202 data sheet for a complete description of the operation of the accelerometer. The part layout of the ADXL202EB is shown in Figure 2. The ADXL202EB has two factory-installed 2200 pF capacitors (C1 and C4) at X_{FILT} and Y_{FILT} to satisfy the minimum filter capacitor specification of the ADXL202. Most applications will likely require narrower bandwidth (and lower noise), in which case a through-hole capacitor may be added in parallel in the space provided at C2 and C3, respectively. When calculating the capacitance required to achieve the desired analog bandwidth, do not forget to subtract the 2200 pF already on the PCB. The pinout description of the ADXL202EB is shown in Table II.

SETTING THE PERIOD OF THE DUTY CYCLE MODULATOR

The DCM period is set by R_{SET} . Choose a value between 100 k Ω and 2 M Ω . See Table III for some typical R_{SET} values.

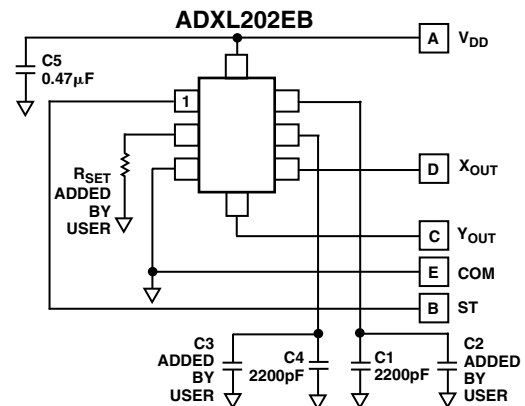

Figure 1. ADXL202EB Schematic

REV. A

Information furnished by Analog Devices is believed to be accurate and reliable. However, no responsibility is assumed by Analog Devices for its use, nor for any infringements of patents or other rights of third parties that may result from its use. No license is granted by implication or otherwise under any patent or patent rights of Analog Devices. Trademarks and registered trademarks are the property of their respective companies.

ADXL202EB

Table I. ADXL202EB Parts List

Reference	Value	Function
C1	2200 pF/25 V	X_{FILT} . Sets X axis analog bandwidth along with C2.
C2	Added by User	X_{FILT} . Sets X axis analog bandwidth along with C1.
C3	Added by User	Y_{FILT} . Sets Y axis analog bandwidth along with C4.
C4	2200 pF/25 V	Y_{FILT} . Sets Y axis analog bandwidth along with C3.
C5	0.47 μ F	Power Supply Bypass
J1	Connector	All power and signal connections made through J1.
R1	Added by User	R_{SET} . Sets the PWM period (T_2).
U1	ADXL202	Dual Axis $\pm 2 g$ Accelerometer

Table II. ADXL202EB Pinout Description

Pin Reference	Pinout
E	Ground
B	Self-Test Input
D	X Axis Duty Cycle Out
C	Y Axis Duty Cycle Out
A	+V Supply (3 V to 5 V DC)

Table III. DCM Period vs. R_{SET} Value

T_2 Period (ms)	R_{SET}
1	124 k Ω
2	248 k Ω
5	620 k Ω
10	1.24 M Ω

Table IV. Typical X_{FILT} and Y_{FILT} Values vs. Bandwidth and Noise Performance

X_{FILT} , Y_{FILT} (μ F)	Bandwidth (Hz)	RMS Noise (mg)
0.01	500	12.7
0.047	100	7
0.1	50	4.2
0.47	10	2.3

SETTING THE ADXL202's BANDWIDTH

The ADXL202EB is supplied with the minimum specified X_{FILT} and Y_{FILT} values installed. Applications will likely require a narrower bandwidth to improve noise performance. See Table IV for some typical capacitor values.

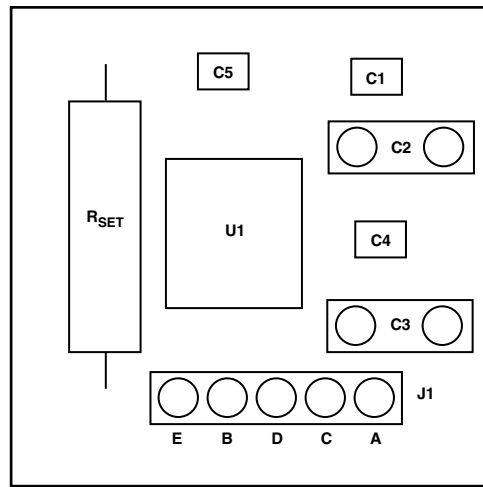

Figure 2. ADXL202EB Part Layout (Top View)

SPECIAL NOTES ON HANDLING

Note that the ADXL202EB is not reverse polarity protected. Reversing the $+V_{SUPPLY}$ and ground pins will damage the ADXL202.

Dropping the ADXL202EB on a hard surface may generate several thousand g of acceleration, enough to damage the accelerometer. Please refer to the ADXL202 data sheet for information on shock survivability.