

CKG45NX7R2A225M500JJ

TDK item description : CKG45NX7R2A225MT***



Application & Main Feature

Automotive grade (MEGACAP)

Series

CKG45N(4532) [EIA 1812]

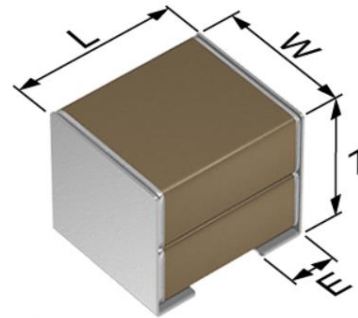

Dimensions

L 5.00±0.50 mm
W 3.50±0.50 mm
T 5.00±0.50 mm
E 1.10±0.30 mm

Temperature Characteristic

X7R (-55 to +125 degC, ±15%)

Rated Voltage

2A (100Vdc)

Capacitance

2.2µF

Capacitance Tolerance

M (±20%)

DF

3 % max.

Insulation Resistance

227 Mohm min.

AEC-Q200

Yes

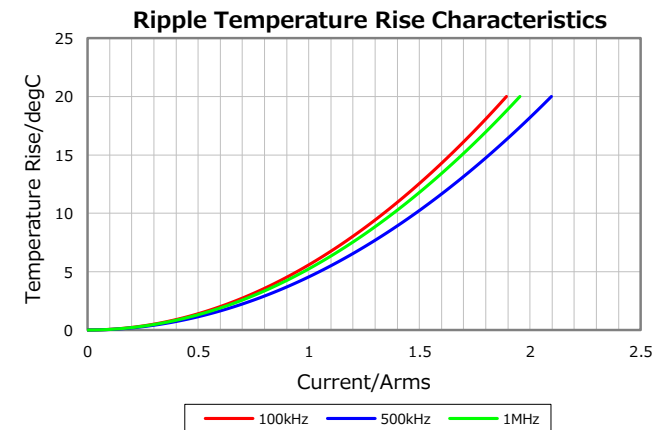
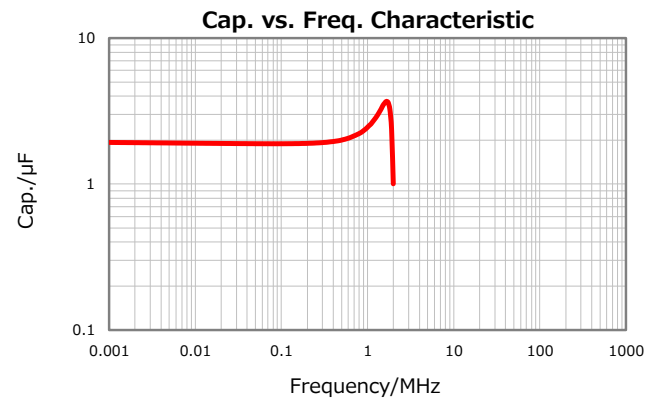
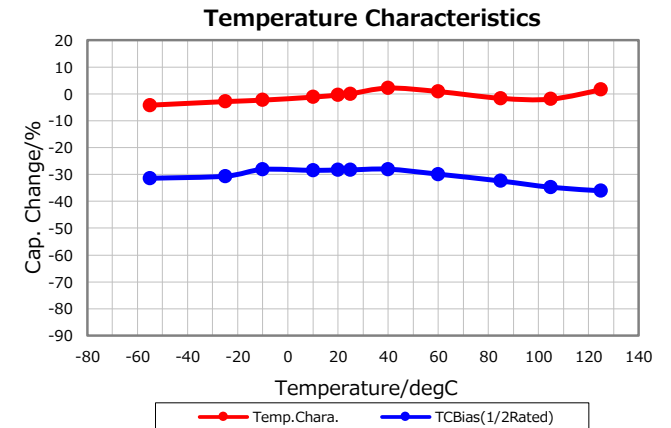
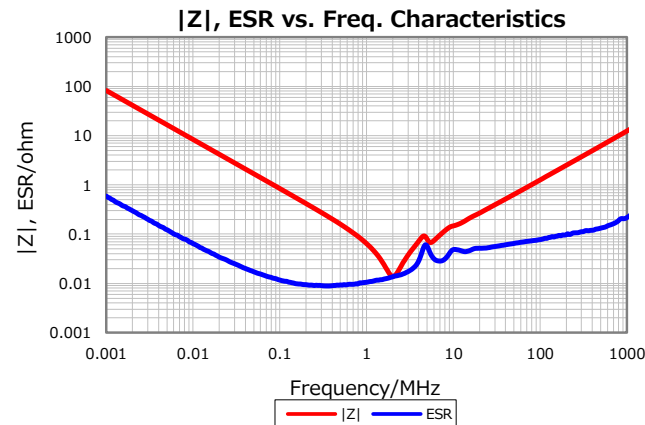
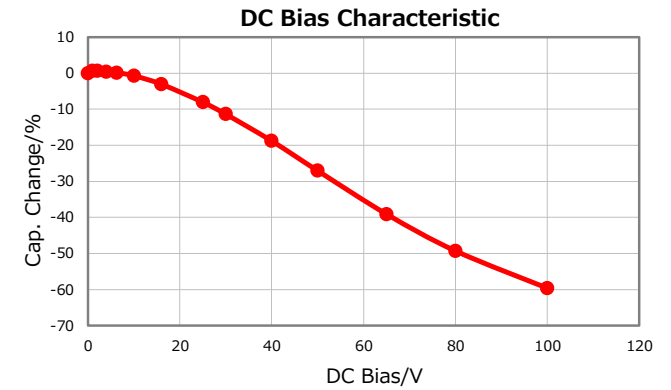

Characterization Sheet (Multilayer Ceramic Chip Capacitors)



All specifications are subject to change without notice.

April 10, 2022