

LQH44PN3R3MP0#

“#” indicates a package specification code.

Size Code 4040 (1515) in mm (in inch), 1.8mm max. Thickness



< List of part numbers with package codes >
LQH44PN3R3MP0K LQH44PN3R3MP0L

Appearance & Shape

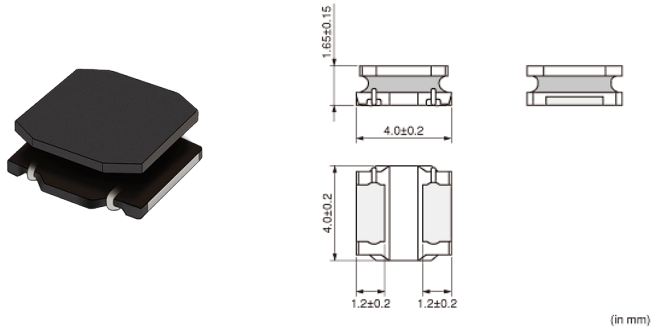

References

Packaging	Specifications	Standard Packing Quantity
K	330 Embossed Tape	3500
L	180 Embossed Tape	1000

Mass (typ.)	
1 piece	0.1g

Notices

When rated current is applied to the products, inductance will be within $\pm 30\%$ of nominal inductance value. When rated current is applied to the products, temperature rise caused by self-generated heat shall be limited to 40°C max. Keep the temperature (ambient temperature plus self-generation of heat) under 125°C.

Attention
1. This datasheet is downloaded from the website of Murata Manufacturing Co., Ltd. Therefore, its specifications are subject to change or our products in it may be discontinued without advance notice. Please check with our sales representatives or product engineers before ordering.
2. This datasheet has only typical specifications because there is no space for detailed specifications. Therefore, please review our product specifications or consult the approval sheet for product specifications before ordering.

LQH44PN3R3MP0#

“#” indicates a package specification code.



Specifications

L size	4.0±0.2mm
W size	4.0±0.2mm
T size	1.65±0.15mm
Size code inch (mm)	1515 (4040)
Inductance	3.3μH±20%
Inductance Test Frequency	1MHz
Rated current (Isat) (Based on Inductance change)	2100mA
Rated current (Itemp) (Based on Temperature rise)	1770mA
Max. of DC resistance	0.078Ω
Operating Temperature Range (Self-temperature rise is included)	-40°C to 125°C
Class of magnetic shield	Magnetic Resin
Self resonance frequency (min.)	50MHz
Operating Temperature Range (Self-temperature rise is not included)	-40°C to 85°C
Brand	Murata
DC Resistance Intermediate Values	0.065Ω±20%
Series	LQH44PN_P0

Attention

- 1.This datasheet is downloaded from the website of Murata Manufacturing Co., Ltd. Therefore, it's specifications are subject to change or our products in it may be discontinued without advance notice. Please check with our sales representatives or product engineers before ordering.
- 2.This datasheet has only typical specifications because there is no space for detailed specifications. Therefore, please review our product specifications or consult the approval sheet for product specifications before ordering.

LQH44PN3R3MP0#

"#" indicates a package specification code.

Characteristic Data

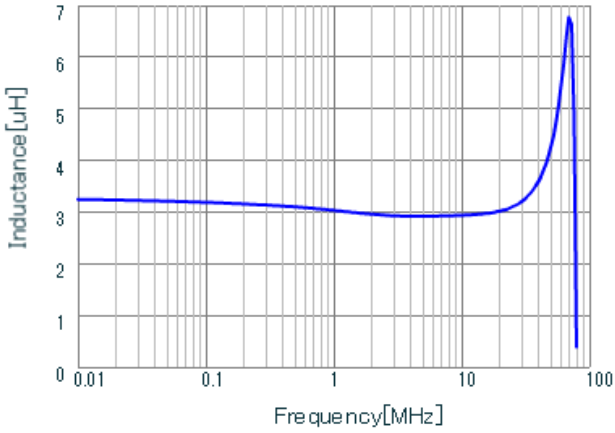

LQH44PN3R3MP0 L

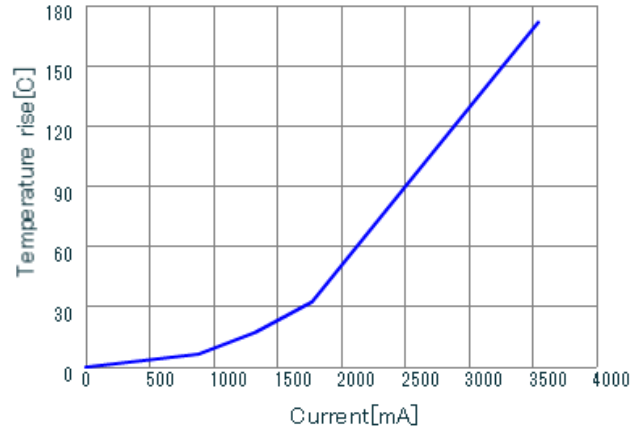

LQH44PN3R3MP0 DT_Current

Inductance - Frequency Characteristics

Temperature Increase Characteristic

Attention

- 1.This datasheet is downloaded from the website of Murata Manufacturing Co., Ltd. Therefore, it's specifications are subject to change or our products in it may be discontinued without advance notice. Please check with our sales representatives or product engineers before ordering.
- 2.This datasheet has only typical specifications because there is no space for detailed specifications. Therefore, please review our product specifications or consult the approval sheet for product specifications before ordering.