

- Ideal for 418.0 MHz Remote Control and Security Transmitters
- Very Low Series Resistance
- Quartz Stability
- Surface-mount Ceramic Case
- Complies with Directive 2002/95/EC (RoHS)



The RO3103D is a true one-port, surface-acoustic-wave (SAW) resonator in a surface-mount, ceramic case. It provides reliable, fundamental-mode, quartz frequency stabilization of fixed-frequency transmitters operating at 418.0 MHz. This SAW is designed specifically for transmitters used in remote control and wireless security applications.

Absolute Maximum Ratings

Rating	Value	Units
CW RF Power Dissipation (See Test Circuit)	0	dBm
DC Voltage Between Terminals (Observe ESD Precautions)	12	VDC
Case Temperature	-40 to +85	°C
Soldering Temperature (10 seconds / 5 cycles maximum)	260	°C

RO3103D

**418.00 MHz
SAW
Resonator**

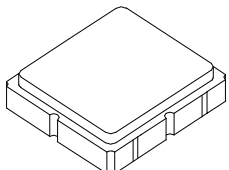

**SM3838-6 Case
3.8 x 3.8 mm**

Electrical Characteristics

Characteristic		Sym	Notes	Minimum	Typical	Maximum	Units
Frequency, +25 °C	Nominal Frequency	f_C	2, 3, 4, 5	417.925		418.075	MHz
	Tolerance from 418.0 MHz	Δf_C					
Insertion Loss		IL	2, 5, 6		1.4	2.0	dB
Quality Factor	Unloaded Q	Q_U	5, 6, 7		10400		
	50 Ω Loaded Q	Q_L			1400		
Temperature Stability	Turnover Temperature	T_O	6, 7, 8	10	25	40	°C
	Turnover Frequency	f_O			f_C		
	Frequency Temperature Coefficient	FTC			0.032		
Frequency Aging	Absolute Value during the First Year	$ f_A $	1, 6		10		ppm/yr
DC Insulation Resistance between Any Two Terminals			5	1.0			MΩ
RF Equivalent RLC Model	Motional Resistance	R_M	5, 6, 7, 9		16.7		Ω
	Motional Inductance	L_M			64.8		μH
	Motional Capacitance	C_M			2.2		fF
	Transducer Static Capacitance	C_O		5, 6, 9	2.4		pF
Test Fixture Shunt Inductance		L_{TEST}	2, 7		60.1		nH
Lid Symbolization				717 // YWWS			
Standard Reel Quantity	Reel Size 7 Inch		10	500 Pieces/Reel			
	Reel Size 13 Inch			3000 Pieces/Reel			

CAUTION: Electrostatic Sensitive Device. Observe precautions for handling.

NOTES:

1. Frequency aging is the change in f_C with time and is specified at +65 °C or less. Aging may exceed the specification for prolonged temperatures above +65 °C. Typically, aging is greatest the first year after manufacture, decreasing in subsequent years.
2. The center frequency, f_C , is measured at the minimum insertion loss point, IL_{MIN} , with the resonator in the 50 Ω test system (VSWR ≤ 1.2:1). The shunt inductance, L_{TEST} , is tuned for parallel resonance with C_O at f_C . Typically, $f_{OSCILLATOR}$ or $f_{TRANSMITTER}$ is approximately equal to the resonator f_C .
3. One or more of the following United States patents apply: 4,454,488 and 4,616,197.
4. Typically, equipment utilizing this device requires emissions testing and government approval, which is the responsibility of the equipment manufacturer.
5. Unless noted otherwise, case temperature $T_C = +25 \pm 2$ °C.
6. The design, manufacturing process, and specifications of this device are subject to change.
7. Derived mathematically from one or more of the following directly measured parameters: f_C , IL, 3 dB bandwidth, f_C versus T_C , and C_O .
8. Turnover temperature, T_O , is the temperature of maximum (or turnover) frequency, f_O . The nominal frequency at any case temperature, T_C , may be calculated from: $f = f_O [1 - FTC (T_O - T_C)^2]$. Typically *oscillator* T_O is approximately equal to the specified *resonator* T_O .
9. This equivalent RLC model approximates resonator performance near the resonant frequency and is provided for reference only. The capacitance C_O is the static (nonmotional) capacitance between the two terminals measured at low frequency (10 MHz) with a capacitance meter. The measurement includes parasitic capacitance with "NC" pads unconnected. Case parasitic capacitance is approximately 0.05 pF. Transducer parallel capacitance can be calculated as: $C_P \approx C_O - 0.05$ pF.
10. Tape and Reel Standard Per ANSI / EIA 481.

Electrical Connections

The SAW resonator is bidirectional and may be installed with either orientation. The two terminals are interchangeable and unnumbered. The callout NC indicates no internal connection. The NC pads assist with mechanical positioning and stability. External grounding of the NC pads is recommended to help reduce parasitic capacitance in the circuit.

Pin	Connection
1	NC
2	Terminal
3	NC
4	NC
5	NC
6	Terminal
7	NC
8	NC

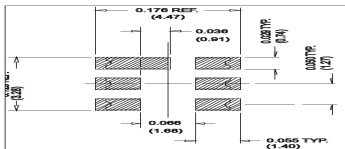
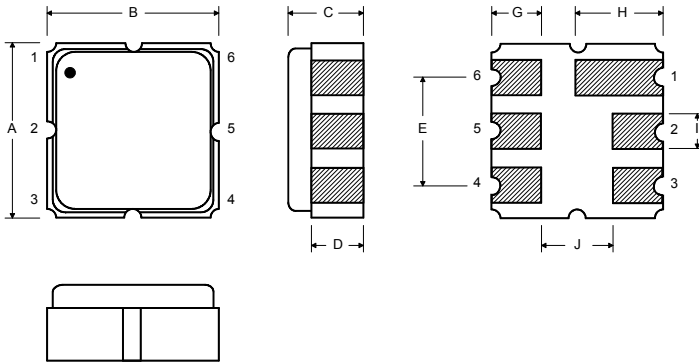

Case Dimensions

Dimension	mm			Inches		
	Min	Nom	Max	Min	Nom	Max
A	3.60	3.80	4.00	0.142	0.150	0.157
B	3.60	3.80	4.00	0.142	0.150	0.157
C	1.10	1.30	1.50	0.043	0.050	0.060
D	0.95	1.10	1.25	0.037	0.043	0.049
E	2.39	2.54	2.69	0.094	0.100	0.106
G	0.90	1.00	1.10	0.035	0.040	0.043
H	1.90	2.00	2.10	0.748	0.079	0.083
I	0.50	0.60	0.70	0.020	0.024	0.028
J	1.70	1.80	1.90	0.067	0.071	0.075

Equivalent RLC Model

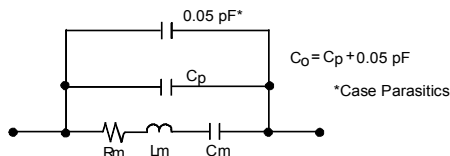

Parameter Test Circuit

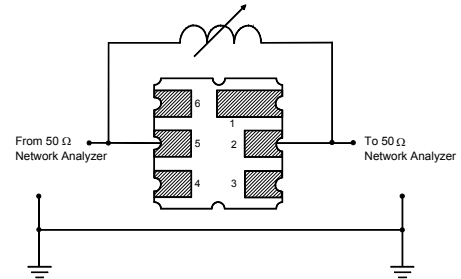

Power Test Circuit

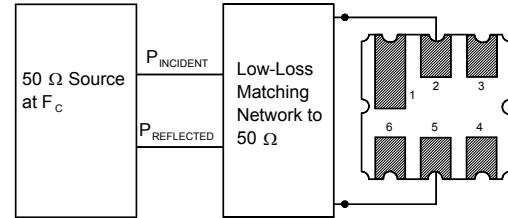

Example Application Circuits

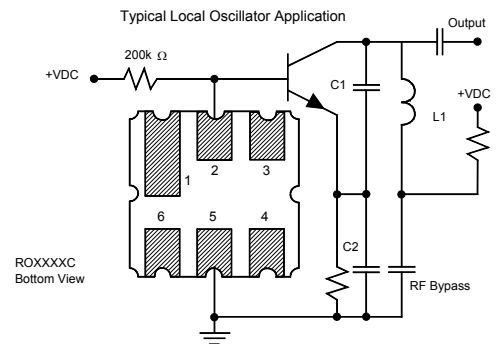
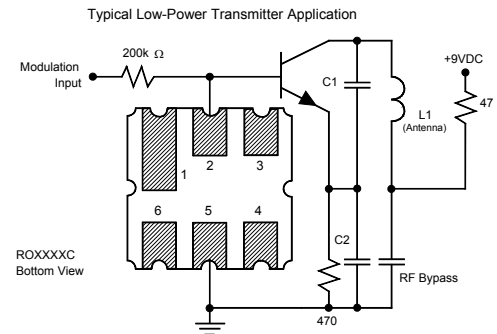

Temperature Characteristics

The curve shown on the right accounts for resonator contribution only and does not include LC component temperature contributions.

