

# S29AL032D Known Good Die

16 Megabit (2 M x 8-Bit/1 M x 16-Bit)  
CMOS 3.0 Volt-only, Boot Sector Flash Memory



*Supplement*

---

## General Description

The S29AL032D in Known Good Die (KGD) form is 32 Mbit, 3.0 volt-only Flash memory. Spansion defines KGD as standard product in die form, tested for functionality and speed. Spansion KGD products have the same reliability and quality as Spansion products in packaged form.

## Distinctive Characteristics

- **Single power supply operation**
  - 2.7 to 3.6 V for read, program, and erase operations
- **Manufactured on 200  $\mu$ m process technology**
- **High performance**
  - Access times as fast as 90 ns
- **Ultra low power consumption (typical values at 5 MHz)**
  - 200 nA Automatic Sleep mode current
  - 200 nA standby mode current
  - 9mA read current
  - 20 mA program/erase current
- **Flexible sector architecture**
  - Eight 8 Kbyte, sixty-three 64 Kbyte; top or bottom boot block configurations available
  - Supports full chip erase
- **Sector Protection**
  - A hardware method of locking a sector to prevent any program or erase operations within that sector
  - Sectors can be locked in-system or via programming equipment
  - Temporary Sector Unprotect feature allows code changes in previously locked sectors
- **Unlock Bypass Program Command**
  - Reduces overall programming time when issuing multiple program command sequences
- **Embedded Algorithms**
  - Embedded Erase algorithm automatically preprograms and erases the entire chip or any combination of designated sectors
  - Embedded Program algorithm automatically writes and verifies data at specified addresses
- **Compatibility with JEDEC standards**
  - Pinout and software compatible with single-power supply Flash
  - Superior inadvertent write protection
- **CFI (Common Flash Interface) compliant**
  - Provides device-specific information to the system, allowing host software to easily reconfigure for different Flash devices
- **Data# Polling and toggle bits**
  - Provides a software method of detecting program or erase operation completion
- **Ready/Busy# pin (RY/BY#)**
  - Provides a hardware method of detecting program or erase cycle completion
- **Erase Suspend/Erase Resume**
  - Suspends an erase operation to read data from, or program data to, a sector that is not being erased, then resumes the erase operation
- **Hardware reset pin (RESET#)**
  - Hardware method to reset the device to reading array data
- **20-year typical data retention**
- **1,000,000 cycle typical endurance per sector**
- **Tested to data sheet specifications at temperature**
- **Quality and reliability levels equivalent to standard packaged components**

## S29AL032D Features

The S29AL032D is a 32 Mbit, 3.0 volt-only Flash memory organized as 4,194,304 bytes or 2,097,152 words. The word-wide data (x16) appears on DQ15–DQ0; the byte-wide (x8) data appears on DQ7–DQ0. To eliminate bus contention, the device has separate chip enable (CE#), write enable (WE#) and output enable (OE#) controls.

The device requires only a **single 3.0 volt power supply** for both read and write functions. Internally generated and regulated voltages are provided for the program and erase operations. No VPP is required for program or erase operations. The device can also be programmed in standard EPROM programmers.

The device is entirely command set compatible with the **JEDEC single-power-supply Flash standard**. Commands are written to the command register using standard microprocessor write timings. Register contents serve as input to an internal state-machine that controls the erase and programming circuitry. Write cycles also internally latch addresses and data needed for the programming and erase operations. Reading data out of the device is similar to reading from other Flash or EPROM devices.

Device programming occurs by executing the program command sequence. This initiates the **Embedded Program** algorithm—an internal algorithm that automatically times the program pulse widths and verifies proper cell margin. The **Unlock Bypass** mode facilitates faster programming times by requiring only two write cycles to program data instead of four.

Device erasure occurs by executing the erase command sequence. This initiates the **Embedded Erase** algorithm—an internal algorithm that automatically preprograms the array (if it is not already programmed) before executing the erase operation. During erase, the device automatically times the erase pulse widths and verifies proper cell margin.

The host system can detect whether a program or erase operation is complete by observing the RY/BY# pin, or by reading the DQ7 (Data# Polling) and DQ6 (toggle) **status bits**. After a program or erase cycle is completed, the device is ready to read array data or accept another command.

The **sector erase architecture** allows memory sectors to be erased and reprogrammed without affecting the data contents of other sectors. The device is fully erased when shipped from the factory.

**Hardware data protection** measures include a low  $V_{CC}$  detector that automatically inhibits write operations during power transitions. The **hardware sector protection** feature disables both program and erase operations in any combination of the sectors of memory. This can be achieved in-system or via programming equipment.

The **Erase Suspend** feature enables the user to put erase on hold for any period of time to read data from, or program data to, any sector that is not selected for erasure. True background erase can thus be achieved.

The **hardware RESET#** input terminates any operation in progress and resets the internal state machine to reading array data. The RESET# pin may be tied to the system reset circuitry. A system reset would thus also reset the device, enabling the system microprocessor to read the boot-up firmware from the Flash memory.

The device offers two power-saving features. When addresses are stable for a specified amount of time, the device enters the **automatic sleep mode**. The system can also place the device into the **standby mode**. Power consumption is greatly reduced in both these modes.

Spansion's Flash technology combines years of Flash memory manufacturing experience to produce the highest levels of quality, reliability and cost effectiveness. The device electrically erases all bits within a sector simultaneously via Fowler-Nordheim tunneling. The data is programmed using hot electron injection.

## Table of Contents

General Description .....	1
Distinctive Characteristics .....	1
S29AL032D Features .....	2
1. Electrical Specifications .....	4
2. Die Photograph & Pad Locations .....	4
3. Pad Description .....	5
3.1 Pad Relative to Die Center .....	5
3.2 Pads Relative to $V_{CC}$ .....	6
4. Ordering Information .....	7
4.1 Valid Combinations .....	7
5. Packaging Information .....	8
5.1 Surftape Packaging .....	8
5.2 Waffle Pack Packaging .....	8
6. Product Test Flow .....	9
7. Physical Specifications .....	10
8. DC Operating Conditions .....	10
9. Manufacturing Information .....	10
10. Special Handling Instructions .....	10
10.1 Processing .....	10
10.2 Storage .....	10
11. Terms and Conditions of Sale for Spansion Non-Volatile Memory Die .....	11
12. Revision History .....	12

## 1. Electrical Specifications

Refer to the S29AL032D data sheet, publication number S29AL032D\_00, for full electrical specifications on the S29AL032D in KGD form.

Family Part Number	S29AL032D KGD
Speed Option ( $V_{CC} = 2.7 - 3.6\text{ V}$ )	90
Max Access Time, $t_{ACC}$ (ns)	90
Max CE# Access, $t_{CE}$ (ns)	90
Max OE# Access, $t_{OE}$ (ns)	35

## 2. Die Photograph & Pad Locations

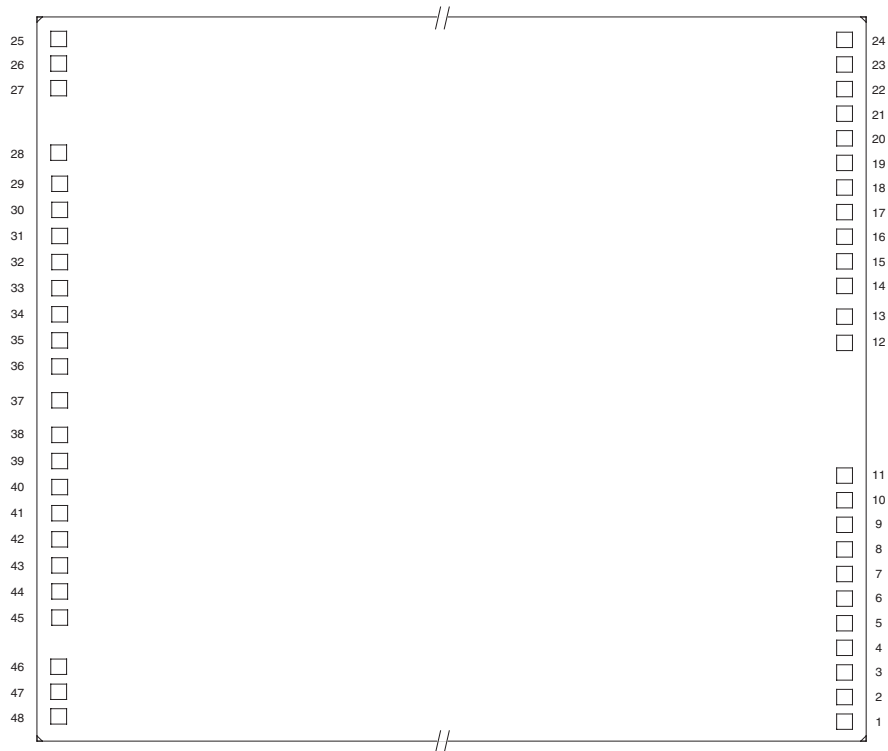
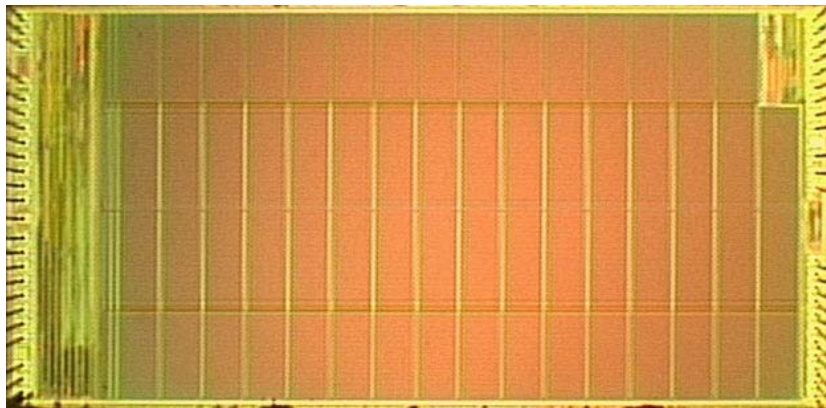

**Note**  
Wirebond must be 100% within bond pad opening.

### 3. Pad Description

#### 3.1 Pad Relative to Die Center

See pad description relative to die center in [Table 3.1](#).

**Table 3.1** Pads Relative to Die Center

Pad No.	Signal	Pad Center (mils)		Pad Center (millimeters)		Pad No.	Signal	Pad Center (mils)		Pad Center (millimeters)	
		X	Y	X	Y			X	Y	X	Y
1	A15	71.057	151.857	1.805	3.857	25	A0	-70.520	-151.836	-1.791	-3.857
2	A14	65.954	151.857	1.675	3.857	26	CE#	-65.418	-151.836	-1.662	-3.857
3	A13	60.852	151.857	1.546	3.857	27	VSS	-60.314	-151.836	-1.532	-3.857
4	A12	55.750	151.857	1.416	3.857	28	OE#	-46.941	-151.836	-1.192	-3.857
5	A11	50.647	151.857	1.286	3.857	29	DQ0	-40.480	-151.630	-1.028	-3.851
6	A10	45.545	151.857	1.157	3.857	30	DQ8	-35.066	-151.630	-0.891	-3.851
7	A9	40.443	151.857	1.027	3.857	31	DQ1	-29.661	-151.630	-0.753	-3.851
8	A8	35.340	151.857	0.898	3.857	32	DQ9	-24.247	-151.630	-0.616	-3.851
9	A19	30.238	151.857	0.768	3.857	33	DQ2	-18.834	-151.630	-0.478	-3.851
10	A20	25.136	151.857	0.638	3.857	34	DQ10	-13.420	-151.630	-0.341	-3.851
11	WE#	20.033	151.857	0.509	3.857	35	DQ3	-8.016	-151.630	-0.204	-3.851
12	RESET#	-7.494	151.857	-0.190	3.857	36	DQ11	-2.601	-151.630	-0.066	-3.851
13	WP#/ACC	-12.922	151.857	-0.328	3.857	37	VCC	4.414	-151.630	0.112	-3.851
14	RY/BY#	-19.299	151.857	-0.490	3.857	38	DQ4	11.591	-151.630	0.294	-3.851
15	NC	-24.401	151.857	-0.620	3.857	39	DQ12	17.005	-151.630	0.432	-3.851
16	A18	-29.503	151.857	-0.749	3.857	40	DQ5	22.409	-151.630	0.569	-3.851
17	A17	-34.606	151.857	-0.879	3.857	41	DQ13	27.823	-151.630	0.707	-3.851
18	A7	-39.708	151.857	-1.009	3.857	42	DQ6	33.236	-151.630	0.844	-3.851
19	A6	-44.810	151.857	-1.138	3.857	43	DQ14	38.650	-151.630	0.982	-3.851
20	A5	-49.913	151.857	-1.268	3.857	44	DQ7	44.055	-151.630	1.119	-3.851
21	A4	-55.015	151.857	-1.397	3.857	45	DQ15/A-1	49.469	-151.630	1.257	-3.851
22	A3	-60.118	151.857	-1.527	3.857	46	VSS	59.668	-151.836	1.516	-3.857
23	A2	-65.220	151.857	-1.657	3.857	47	BYTE#	64.860	-151.836	1.647	-3.857
24	A1	-70.322	151.857	-1.786	3.857	48	A16	69.963	-151.836	1.777	-3.857

**Note**

The coordinates above are relative to the die center and can be used to operate wire bonding equipment.

### 3.2 Pads Relative to V<sub>CC</sub>

See pad description relative to V<sub>CC</sub> in Table 3.2.

Table 3.2 Pads Relative to V<sub>CC</sub>

Pad No.	Signal	Pad Center (mils)		Pad Center (millimeters)		Pad No.	Signal	Pad Center (mils)		Pad Center (millimeters)	
		X	Y	X	Y			X	Y	X	Y
1	A15	66.643	303.487	1.693	7.708	25	A0	-74.934	-0.206	-1.903	-0.006
2	A14	61.540	303.487	1.563	7.708	26	CE#	-69.832	-0.206	-1.774	-0.006
3	A13	56.438	303.487	1.434	7.708	27	VSS	-64.728	-0.206	-1.644	-0.006
4	A12	51.336	303.487	1.304	7.708	28	OE#	-51.355	-0.206	-1.304	-0.006
5	A11	46.233	303.487	1.174	7.708	29	DQ0	-44.894	0.000	-1.140	0.000
6	A10	41.131	303.487	1.045	7.708	30	DQ8	-39.480	0.000	-1.003	0.000
7	A9	36.029	303.487	0.915	7.708	31	DQ1	-34.075	0.000	-0.865	0.000
8	A8	30.926	303.487	0.786	7.708	32	DQ9	-28.661	0.000	-0.728	0.000
9	A19	25.824	303.487	0.656	7.708	33	DQ2	-23.248	0.000	-0.590	0.000
10	A20	20.722	303.487	0.526	7.708	34	DQ10	-17.834	0.000	-0.453	0.000
11	WE#	15.619	303.487	0.397	7.708	35	DQ3	-12.430	0.000	-0.316	0.000
12	RESET#	-11.908	303.487	-0.302	7.708	36	DQ11	-7.015	0.000	-0.178	0.000
13	WP#/ACC	-17.336	303.487	-0.440	7.708	37	VCC	0.000	0.000	0.000	0.000
14	RY/BY#	-23.713	303.487	-0.602	7.708	38	DQ4	7.177	0.000	0.182	0.000
15	NC	-28.815	303.487	-0.732	7.708	39	DQ12	12.591	0.000	0.320	0.000
16	A18	-33.917	303.487	-0.861	7.708	40	DQ5	17.995	0.000	0.457	0.000
17	A17	-39.020	303.487	-0.991	7.708	41	DQ13	23.409	0.000	0.595	0.000
18	A7	-44.122	303.487	-1.121	7.708	42	DQ6	28.822	0.000	0.732	0.000
19	A6	-49.224	303.487	-1.250	7.708	43	DQ14	34.236	0.000	0.870	0.000
20	A5	-54.327	303.487	-1.380	7.708	44	DQ7	39.641	0.000	1.007	0.000
21	A4	-59.429	303.487	-1.509	7.708	45	DQ15/A-1	45.055	0.000	1.145	0.000
22	A3	-64.532	303.487	-1.639	7.708	46	VSS	55.254	-0.206	1.404	-0.006
23	A2	-69.634	303.487	-1.769	7.708	47	BYTE#	60.446	-0.206	1.535	-0.006
24	A1	-74.736	303.487	-1.898	7.708	48	A16	65.549	-0.206	1.665	-0.006

## 4. Ordering Information

Spansion standard products are available in several packages and operating ranges. The order number (Valid Combination) is formed by a combination of the elements below.

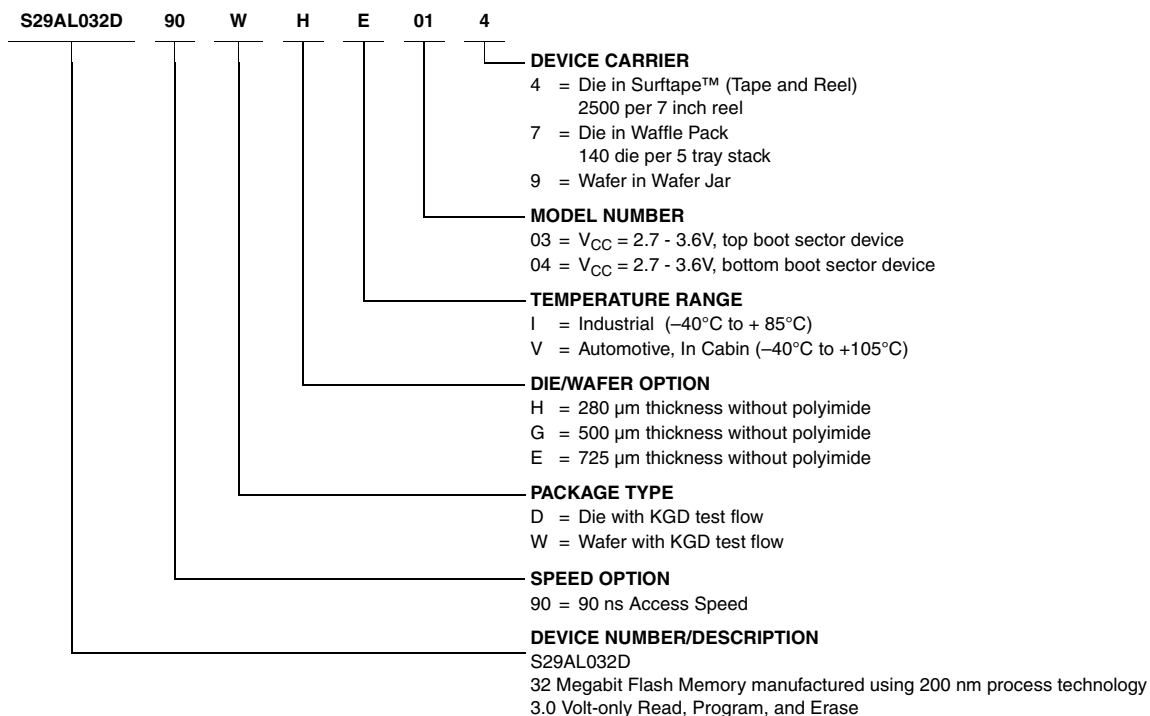

### 4.1 Valid Combinations

Valid Combinations list configurations planned to be supported in volume for this device. Consult the local Spansion sales office to confirm availability of specific valid combinations and to check on newly released combinations.

S29AL032D Valid Combinations				
Device Number	Speed Option	Package Type, and Temperature Range	Model Number	Device Carrier
S29AL032D	90	WHI, WHV, WGI, WGV WEI, WEV	03, 04	9

## 5. Packaging Information

### 5.1 Surftape Packaging

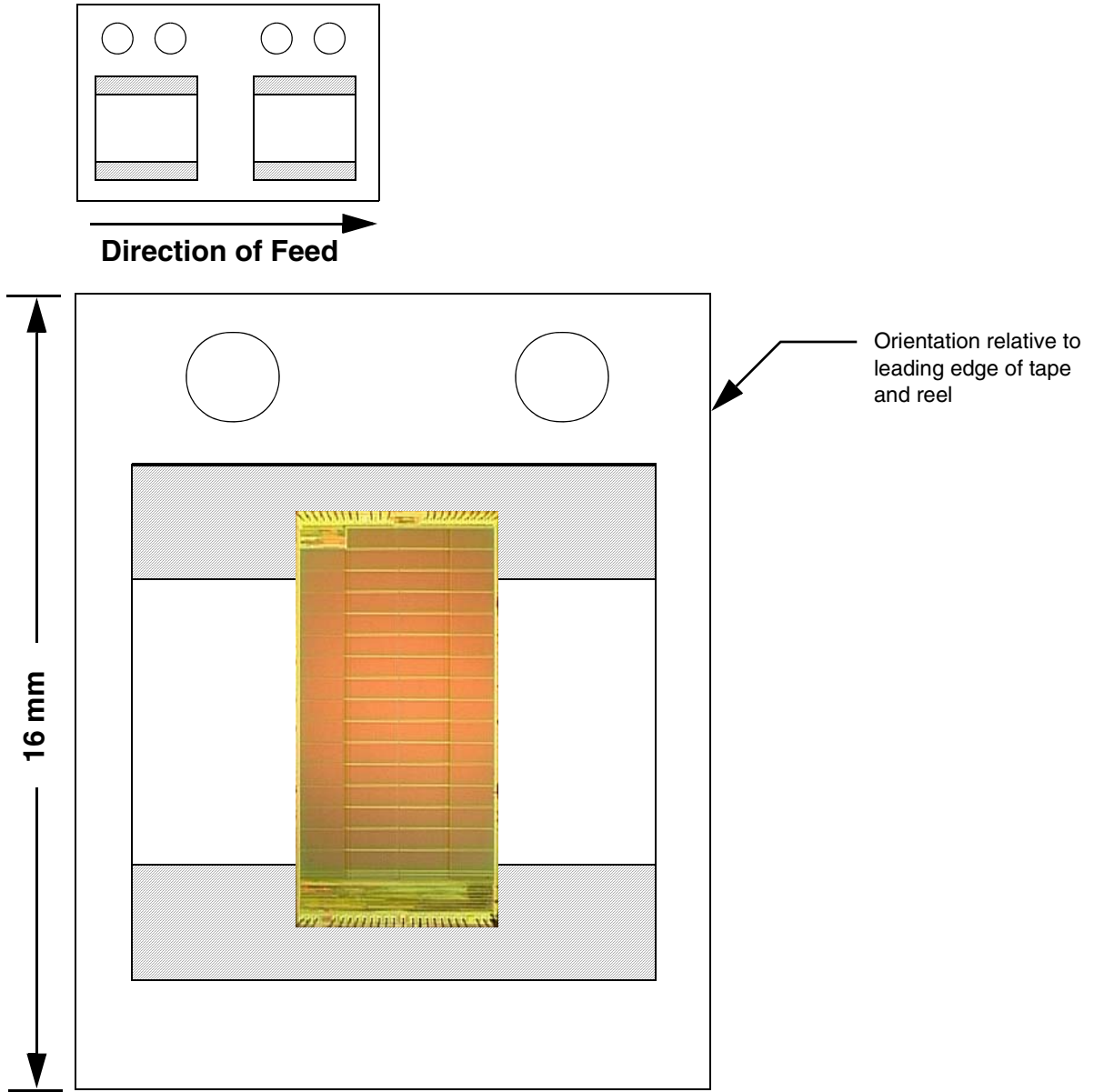

### 5.2 Waffle Pack Packaging

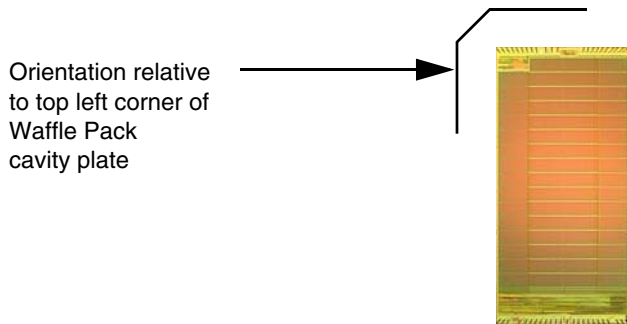



## 6. Product Test Flow

Figure 6.1 provides an overview of Spansion’s Known Good Die test flow. For more detailed information, refer to the S29AL032D product qualification database supplement for KGD. Spansion implements quality assurance procedures throughout the product test flow. In addition, an off-line quality monitoring program (QMP) further guarantees Spansion quality standards are met on Known Good Die products. These QA procedures also allow Spansion to produce KGD products without requiring or implementing burn-in.

Figure 6.1 Spansion KGD Product Test Flow

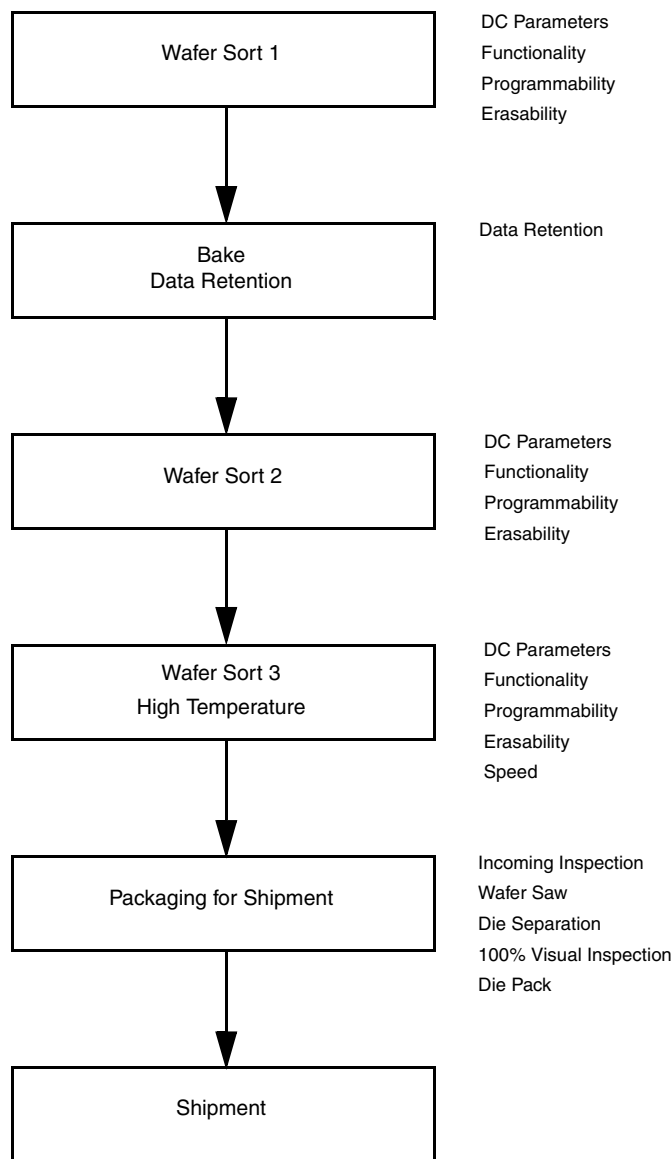

## 7. Physical Specifications

Description	Specification
Die dimensions	153.54 mils X 318.10 mils 3.9 mm x 8.1 mm
Die Thickness	725 $\mu$ m
Bond Pad Size	3.19 mils x 3.19 mils 81 $\mu$ m x 81 $\mu$ m
Pad Area Free of Passivation	10.18 mils <sup>2</sup> 6,561 $\mu$ m <sup>2</sup>
Pads Per Die	48
Bond Pad Metalization	Al/Cu
Die Backside	No metal
Passivation	Nitride/SOG/Nitride

## 8. DC Operating Conditions

Description	Specification
V <sub>CC</sub> (Supply Voltage)	2.7 V to 3.6 V
Operating Temperature	-40°C to +85°C (Industrial) -40°C to +105°C (Automotive, in-cabin)

## 9. Manufacturing Information

Description	Specification
Manufacturing	Spansion
Test	Spansion
Manufacturing ID	(Top Boot) 98M57A (Bottom Boot) 98M57AB
Preparation for Shipment	Penang, Malaysia
Fabrication Process	CS49SS
Die Revision	1

## 10. Special Handling Instructions

### 10.1 Processing

Do not expose KGD products to ultraviolet light or process them at temperatures greater than 250°C. Failure to adhere to these handling instructions will result in irreparable damage to the devices. For best yield, Spansion recommends assembly in a Class 10K clean room with 30% to 60% relative humidity.

### 10.2 Storage

Store at a maximum temperature of 30°C in a nitrogen-purged cabinet or vacuum-sealed bag. Observe all standard ESD handling procedures.

## 11. Terms and Conditions of Sale for Spansion Non-Volatile Memory Die

All transactions relating to unpackaged die under this agreement shall be subject to Spansion's standard terms and conditions of sale, or any revisions thereof, which revisions Spansion reserves the right to make at any time and from time to time. In the event of conflict between the provisions of Spansion's standard terms and conditions of sale and this agreement, the terms of this agreement shall be controlling.

Spansion warrants its manufactured unpackaged die whether shipped to customer in individual dice or wafer form ("Known Good Die," "KGD", "Die," "Known Good Wafer", "KGW", or Wafer(s)) will meet Spansion's published specifications and against defective materials or workmanship for a period of one (1) year from date of shipment.

This limited warranty does not extend beyond the first purchaser of said Die or Wafer(s).

Buyer assumes full responsibility to ensure compliance with the appropriate handling, assembly and processing of KGD or KGW (including but not limited to proper Die preparation, Die attach, backgrinding, singulation, wire bonding and related assembly and test activities), and compliance with all guidelines set forth in Spansion's specifications for KGD or KGW, and Spansion assumes no responsibility for environmental effects on KGD or KGW or for any activity of Buyer or a third party that damages the Die or Wafer(s) due to improper use, abuse, negligence, improper installation, improper backgrinding, improper singulation, accident, loss, damage in transit, or unauthorized repair or alteration by a person or entity other than Spansion ("Limited Warranty Exclusions")

The liability of Spansion under this limited warranty is limited, at Spansion's option, solely to repair the Die or Wafer(s), to send replacement Die or Wafer(s), or to make an appropriate credit adjustment or refund in an amount not to exceed the original purchase price actually paid for the Die or Wafer(s) returned to Spansion, provided that: (a) Spansion is promptly notified by Buyer in writing during the applicable warranty period of any defect or nonconformity in the Die or Wafer(s); (b) Buyer obtains authorization from Spansion to return the defective Die or Wafer(s); (c) the defective Die or Wafer(s) is returned to Spansion by Buyer in accordance with Spansion's shipping instructions set forth below; and (d) Buyer shows to Spansion's satisfaction that such alleged defect or nonconformity actually exists and was not caused by any of the above-referenced Warranty Exclusions. Buyer shall ship such defective Die or Wafer(s) to Spansion via Spansion's carrier, collect. Risk of loss will transfer to Spansion when the defective Die or Wafer(s) is provided to Spansion's carrier. If Buyer fails to adhere to these warranty returns guidelines, Buyer shall assume all risk of loss and shall pay for all freight to Spansion's specified location. The aforementioned provisions do not extend the original limited warranty period of any Die or Wafer(s) that has either been replaced by Spansion.

THIS LIMITED WARRANTY IS EXPRESSED IN LIEU OF ALL OTHER WARRANTIES, EXPRESSED OR IMPLIED, INCLUDING THE IMPLIED WARRANTY OF FITNESS FOR A PARTICULAR PURPOSE, THE IMPLIED WARRANTY OF MERCHANTABILITY OR NONINFRINGEMENT AND OF ALL OTHER OBLIGATIONS OR LIABILITIES ON Spansion's PART, AND IT NEITHER ASSUMES NOR AUTHORIZES ANY OTHER PERSON TO ASSUME FOR Spansion ANY OTHER LIABILITIES. THE FOREGOING CONSTITUTES THE BUYER'S SOLE AND EXCLUSIVE REMEDY FOR THE FURNISHING OF DEFECTIVE OR NON CONFORMING KNOWN GOOD DIE OR KNOWN GOOD WAFER(S) AND Spansion SHALL NOT IN ANY EVENT BE LIABLE FOR INCREASED MANUFACTURING COSTS, DOWNTIME COSTS, DAMAGES RELATING TO BUYER'S PROCUREMENT OF SUBSTITUTE DIE OR WAFER(S) (i.e., "COST OF COVER"), LOSS OF PROFITS, REVENUES OR GOODWILL, LOSS OF USE OF OR DAMAGE TO ANY ASSOCIATED EQUIPMENT, OR ANY OTHER INDIRECT, INCIDENTAL, SPECIAL OR CONSEQUENTIAL DAMAGES BY REASON OF THE FACT THAT SUCH KNOWN GOOD DIE OR KNOWN GOOD WAFER(S) SHALL HAVE BEEN DETERMINED TO BE DEFECTIVE OR NON CONFORMING.

Buyer agrees that it will make no warranty representations to its customers which exceed those given by Spansion to Buyer unless and until Buyer shall agree to indemnify Spansion in writing for any claims which exceed Spansion's limited warranty. Known Good Die or Known Good Wafer(s) are not designed or authorized for use as components in life support appliances, devices or systems where malfunction of the Die or Wafer(s) can reasonably be expected to result in a personal injury. Buyer's use of Known Good Die or Known Good Wafer(s) for use in life support applications is at Buyer's own risk and Buyer agrees to fully indemnify Spansion for any damages resulting in such use or sale.

Known Good Die or Known Good Wafer are not designed or authorized for use as components in life support appliances, devices or systems where malfunction of the die or wafer can reasonably be expected to result in a personal injury. Buyer's use of Known Good Die or Known Good Wafer for use in life support applications is at Buyer's own risk and Buyer agrees to fully indemnify Spansion for any damages resulting in such use or sale.

## 12. Revision History

Section	Description
<b>Revision 01 (December 20, 2006)</b>	
Global	Initial release.
<b>Revision 02 (July 18, 2007)</b>	
Packaging Information	Removed references to Gel-Pak, replaced die photo
Valid Combinations Table	Modified table

**Colophon**

The products described in this document are designed, developed and manufactured as contemplated for general use, including without limitation, ordinary industrial use, general office use, personal use, and household use, but are not designed, developed and manufactured as contemplated (1) for any use that includes fatal risks or dangers that, unless extremely high safety is secured, could have a serious effect to the public, and could lead directly to death, personal injury, severe physical damage or other loss (i.e., nuclear reaction control in nuclear facility, aircraft flight control, air traffic control, mass transport control, medical life support system, missile launch control in weapon system), or (2) for any use where chance of failure is intolerable (i.e., submersible repeater and artificial satellite). Please note that Spansion will not be liable to you and/or any third party for any claims or damages arising in connection with above-mentioned uses of the products. Any semiconductor devices have an inherent chance of failure. You must protect against injury, damage or loss from such failures by incorporating safety design measures into your facility and equipment such as redundancy, fire protection, and prevention of over-current levels and other abnormal operating conditions. If any products described in this document represent goods or technologies subject to certain restrictions on export under the Foreign Exchange and Foreign Trade Law of Japan, the US Export Administration Regulations or the applicable laws of any other country, the prior authorization by the respective government entity will be required for export of those products.

**Trademarks and Notice**

The contents of this document are subject to change without notice. This document may contain information on a Spansion product under development by Spansion. Spansion reserves the right to change or discontinue work on any product without notice. The information in this document is provided as is without warranty or guarantee of any kind as to its accuracy, completeness, operability, fitness for particular purpose, merchantability, non-infringement of third-party rights, or any other warranty, express, implied, or statutory. Spansion assumes no liability for any damages of any kind arising out of the use of the information in this document.

Copyright © 2006–2007 Spansion Inc. All rights reserved. Spansion®, the Spansion Logo, MirrorBit®, MirrorBit® Eclipse™, ORNAND™, HD-SIM™ and combinations thereof, are trademarks of Spansion LLC in the US and other countries. Other names used are for informational purposes only and may be trademarks of their respective owners.