

RS9110-N-11-22 – Wireless Device Server Datasheet

Redpine Signals, Inc.

2107 N. First Street, #680

San Jose, CA 95131.

Tel: (408) 748-3385

Fax: (408) 705-2019

Email: info@redpinesignals.com

Website: www.redpinesignals.com

Overview

Overview

The RS9110-N-11-22 module is a complete IEEE 802.11bgn based wireless device server that directly provides a wireless interface to any equipment with a serial or SPI interface for data transfer. It integrates a MAC, baseband processor, RF transceiver with power amplifier, a frequency reference, and an antenna in hardware; and all WLAN protocol and configuration functionality, networking stack in embedded firmware to make a fully self-contained 802.11n WLAN solution for a variety of applications.

Applications:

- Seamless Wi-Fi connectivity for Application Processors
- Industrial M2M communications
- Point of Sale Terminals
- Metering (Parking Meters, Utility Meters, Power Meters, etc.)
- Security Cameras and Surveillance Equipment
- Logistics and Freight Management
- Warehousing
- Digital Picture Frames

- Several medical applications including Patient Monitoring, Remote Diagnostics

Device Features:

- Compliant to 802.11b/g and single stream 802.11n
- Fully self-contained serial-to-wireless functionality
- Supports WPA2-PSK, WEP (64 and 128 bit) and TKIP security in infrastructure mode
- Supports WEP (64 and 128 bit) security in ad-hoc mode
- Payload data through Serial Interface and SPI
- Terminates TCP and UDP connections
- Configuration through UART/SPI
- Integrated antenna, frequency reference. Option for external antenna through u.FL connector
- Ultra-low-power operation with power-save modes
- Ad-hoc and infrastructure modes for maximum deployment flexibility
- Single supply – 3.1 to 3.6V operation
- Device Dimensions 22mm x 28mm x 2.8mm

RS9110-N-11-22 System Block Diagram

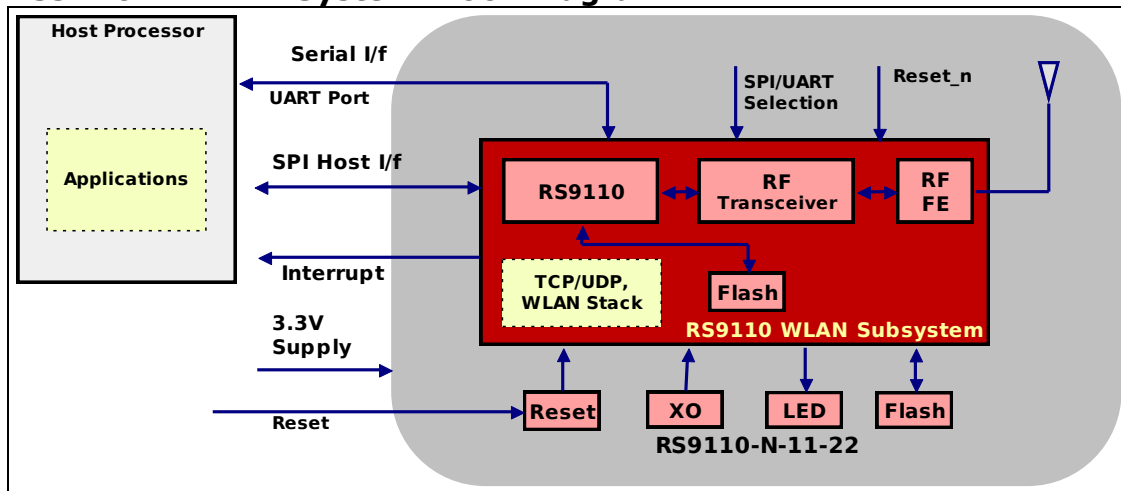

Table of Contents

1	Detailed Feature List.....	7
1.1	Host Interfaces.....	7
1.2	WLAN	7
1.3	Networking Protocols	7
1.4	Configuration.....	8
1.5	Software.....	8
1.6	Compliance and Certification.....	8
2	Package Description	9
2.1	Top View	9
2.2	Bottom View	9
2.3	Package Dimensions	10
2.4	PCB Landing Pattern	11
2.5	Recommended Reflow Profile.....	12
2.6	Baking Instructions	12
3	Pin Description	13
3.1	Module Pinout.....	13
3.2	Pin Description	13
4	Electrical Characteristics	17
4.1	Absolute Maximum Ratings.....	17
4.2	Recommended Operating Conditions.....	17
4.3	DC Characteristics – Digital I/O Signals	17
4.4	AC Characteristics – Digital I/O Signals.....	18
4.4.1	SPI Interface.....	18
4.4.2	Reset Sequence and Timing	18
5	Performance Specifications	20
5.1	Wireless Specifications	20
5.2	Receive Sensitivity.....	20
5.3	Throughput.....	20
5.4	Standards Compliance	21
6	Software Architecture Overview	22
6.1	Host	23
6.1.1	UART	23
6.1.2	SPI	23
6.1.3	Thin SPI Driver.....	23
6.2	RS9110-N-11-22.....	23
6.2.1	SPI	23
6.2.2	UART	24
6.2.3	Host Abstraction Layer (HAL)	24
6.2.4	Wireless Control Block (WCB).....	24
6.2.5	Wi-Fi Control Frames	24
6.2.6	TCP/IP Control Frames	24
6.2.7	Station Management Entity (SME)	24
6.2.8	WPA Supplicant.....	24
6.3	Power Save Modes.....	24

6.3.1	Power Mode 0	25
6.3.2	Power Mode 1	25
6.3.3	Power Mode 2	25
7	Ordering Information	27
	Contact Information	27
	Device Ordering Information	27
	Collateral.....	28
8	Command Reference (AT commands and SPI commands) .	29

Table of Figures

Figure 1:Top View of the Module	9
Figure 2:Bottom View of the Module	9
Figure 3: Package Dimensions.....	10
Figure 4:PCB Landing Pattern	11
Figure 5:Reflow Profile.....	12
Figure 6:Pinout of the Module	13
Figure 7:Interface Timings – SPI Interface	18
Figure 9:Reset Pin Timing Diagram	19
Figure 10:RS9110-N-11-22 Software Architecture Block Diagram	22

List of Tables

Table 1: Pin Description	16
Table 2: Absolute Maximum Ratings.....	17
Table 3: Recommended Operating Conditions	17
Table 4: Input/Output DC Characteristics	17
Table 5: AC Characteristics – SPI Interface.....	18
Table 6: Wireless Specifications	20
Table 7: Receive Characteristics – Sensitivity	20
Table 8: Device Ordering Information	28

1 Detailed Feature List

1.1 Host Interfaces

- UART
 - The UART forms the physical layer of the TCP/IP stack, transferring frames between a Host processor and the module.
 - The UART interface supports variable baud rates from 9600 to 3686400 bps
 - AT Command Interface for configuration and module operation
- SPI
 - Standard 4-wire SPI
 - Operation up to a maximum clock speed of 25MHz¹

1.2 WLAN

MAC

- Conforms to IEEE 802.11b/g/n standards
- Dynamic selection of fragment threshold, data rate, and antenna depending on the channel statistics
- Hardware accelerated implementation of WEP 64/128-bit and AES
- Infrastructure and Ad-hoc modes
- Security - WPA/WPA2-PSK, WEP

Baseband Processing

- Supports DSSS (1, 2 Mbps) and CCK (5.5, 11 Mbps) modes
- Supports all OFDM data rates (6, 9, 12, 18, 24, 36, 48, and 54 Mbps)
- Supports IEEE 802.11n single-stream modes with data rates up to 65 Mbps
- Supports long, short, and HT preamble modes
- High-performance multipath compensation in OFDM, DSSS, and CCK modes

RF

- Highly integrated 2.4 GHz transceiver and Power Amplifier with direct conversion architecture
- Integrated frequency reference and antenna

1.3 Networking Protocols

- TCP
- UDP

¹ This frequency depends on the external delays also.

- ARP
- ICMP
- DHCP Client

The RS9110-N-11-22 comes with flexible frameworks to enable usage in various application scenarios, viz., high throughput, more network features, etc.

1.4 Configuration

The RS9110-N-11-22 module can be configured through UART or SPI. The following are some of the commands that can be given to the module:

- Scan
- Connect
- Pre-shared Keys
- SSID of hidden WLAN networks
- DHCP Enable/Disable
- Create/Join an IBSS (ad-hoc) network
- Open/Close sockets for TCP, UDP

1.5 Software

- Sample Host driver for SPI interface
- Configuration and management GUI for Windows XP for UART
- Embedded software for complete WLAN functionality including 802.11n aggregation and Block-ACK, auto rate adaptation, security and also complete network stack and applications including TCP, UDP, ARP, ICMP, DHCP client.

1.6 Compliance and Certification

- Reference design is FCC, IC, and CE certified
- RoHS (Restriction of Hazardous Substances) compliant

2 Package Description

2.1 Top View



Figure 1:Top View of the Module

2.2 Bottom View

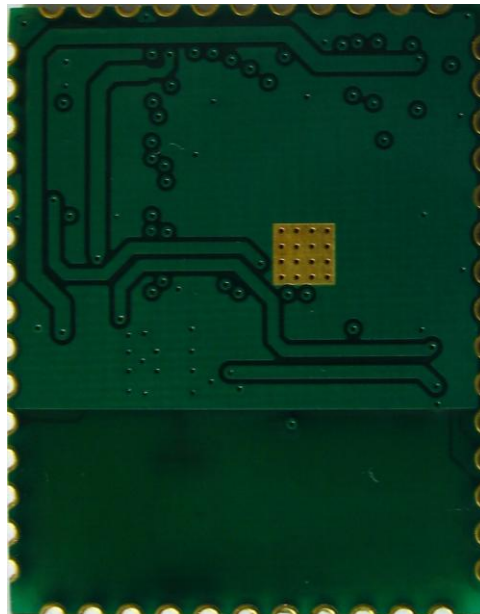

Figure 2:Bottom View of the Module

2.3 Package Dimensions

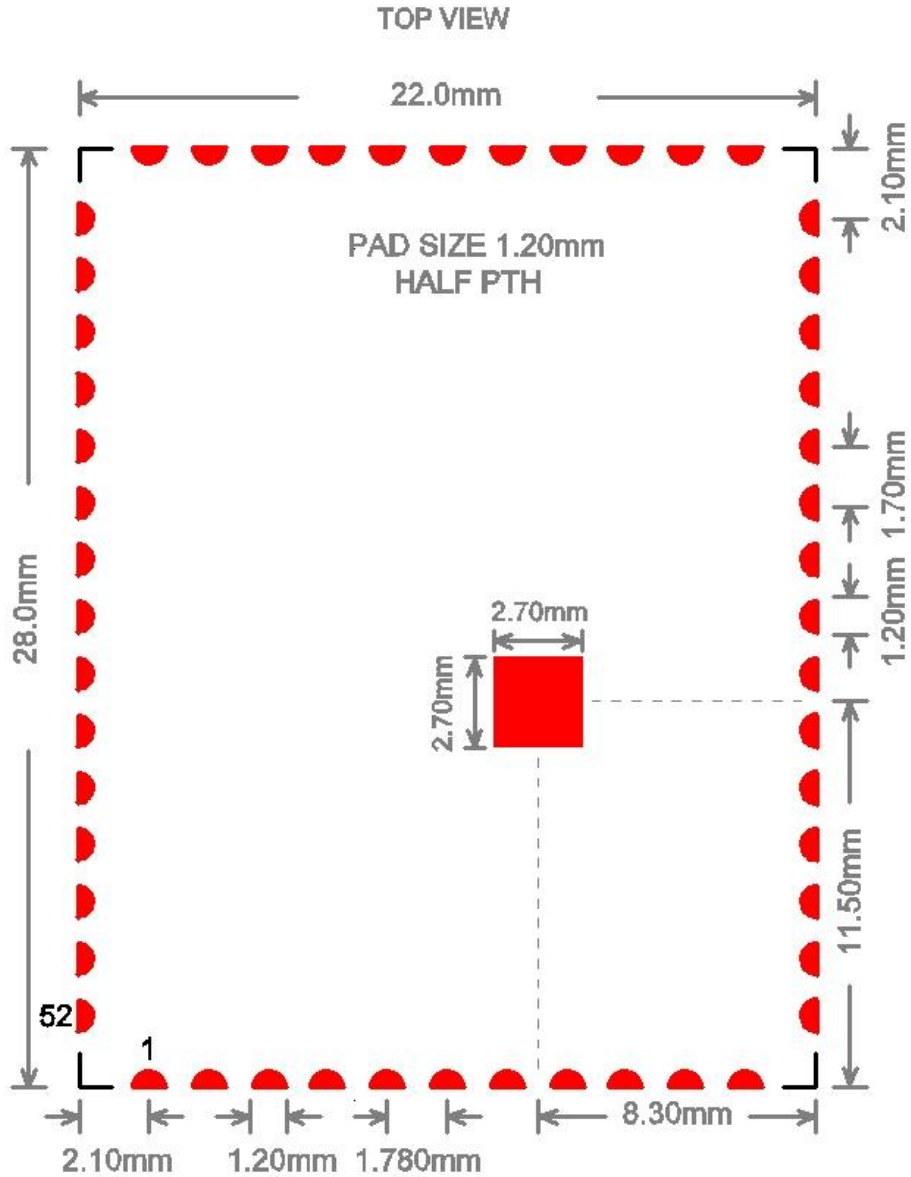

Figure 3: Package Dimensions

Module height = 2.8 mm

2.4 PCB Landing Pattern

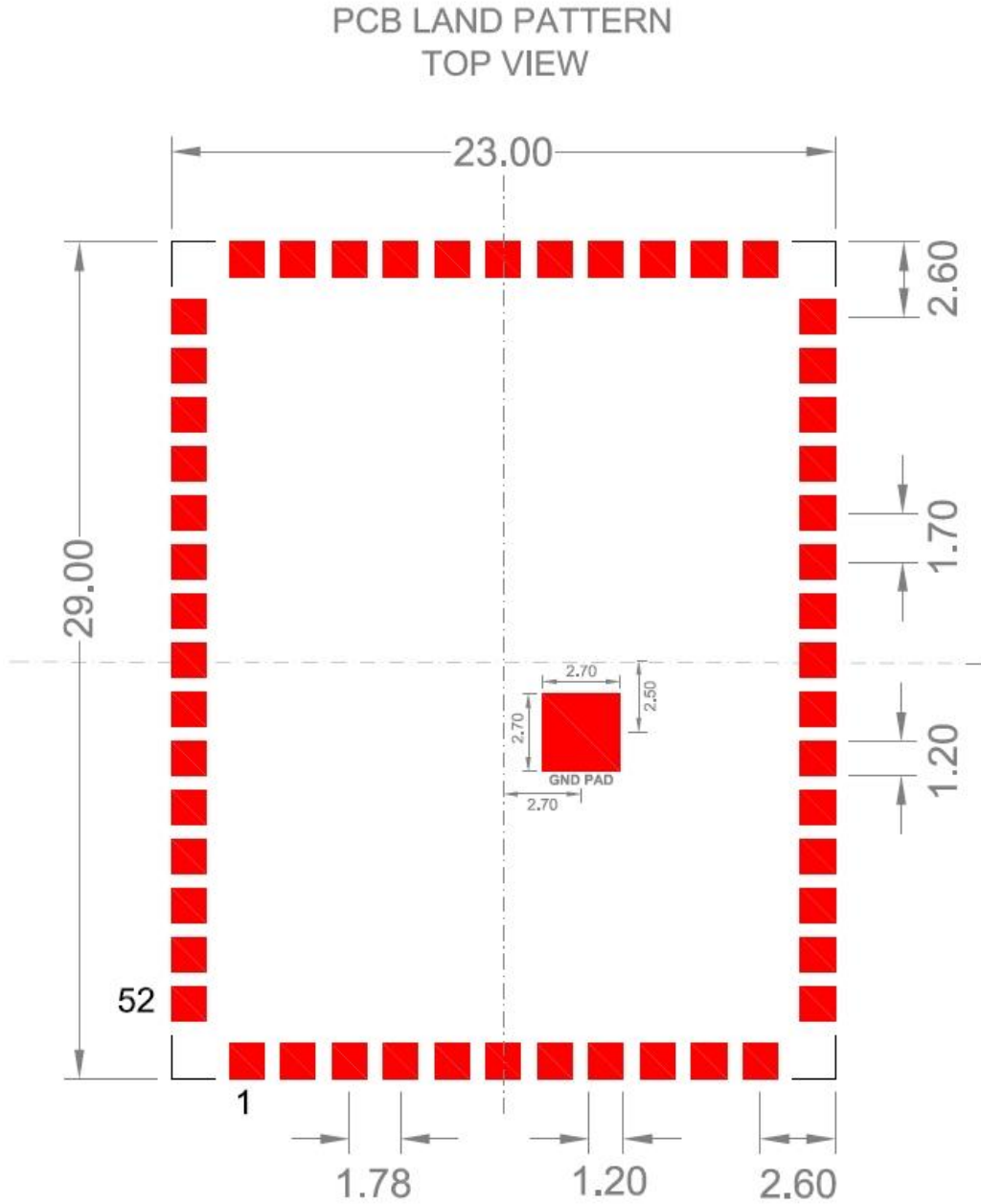

Figure 4:PCB Landing Pattern

2.5 Recommended Reflow Profile

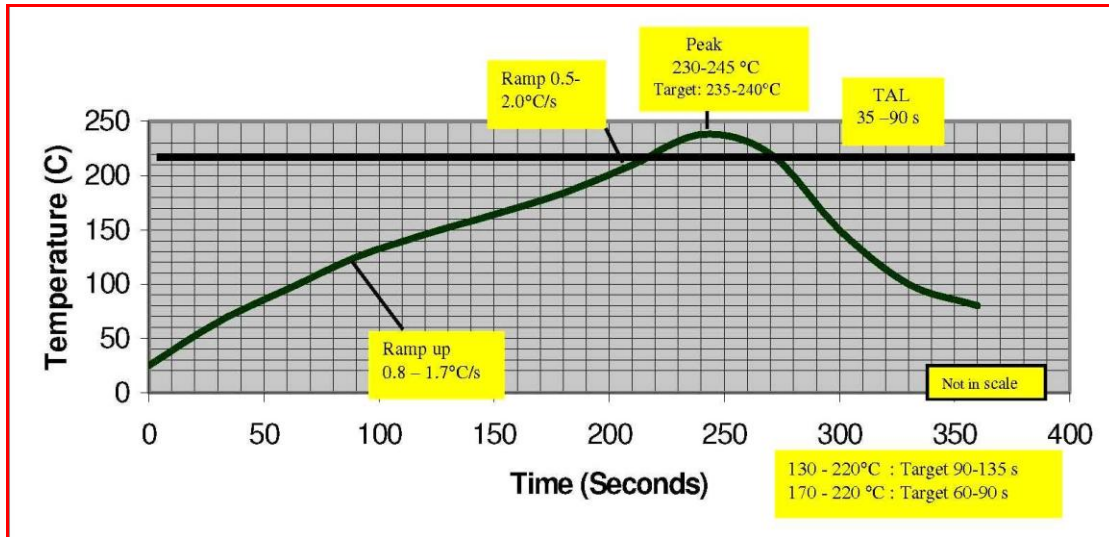

Figure 5: Reflow Profile

NOTE: The profile shown is based on SAC 305 solder (3% silver, 0.5% copper). We recommend the ALPHA OM-338 lead-free solder paste. This profile is provided mainly for guidance. The total dwell time depends on the thermal mass of the assembled board and the sensitivity of the components on it.

2.6 Baking Instructions

The RS9110-N-11-22 package is moisture sensitive and devices must be handled appropriately. After the devices are removed from their vacuum sealed packs, they should be taken through reflow for board assembly within 168 hours at room conditions, or stored at under 10% relative humidity. If these conditions are not met, the devices must be baked before reflow. The recommended baking time is nine hours at 125° C.

3 Pin Description

3.1 Module Pinout

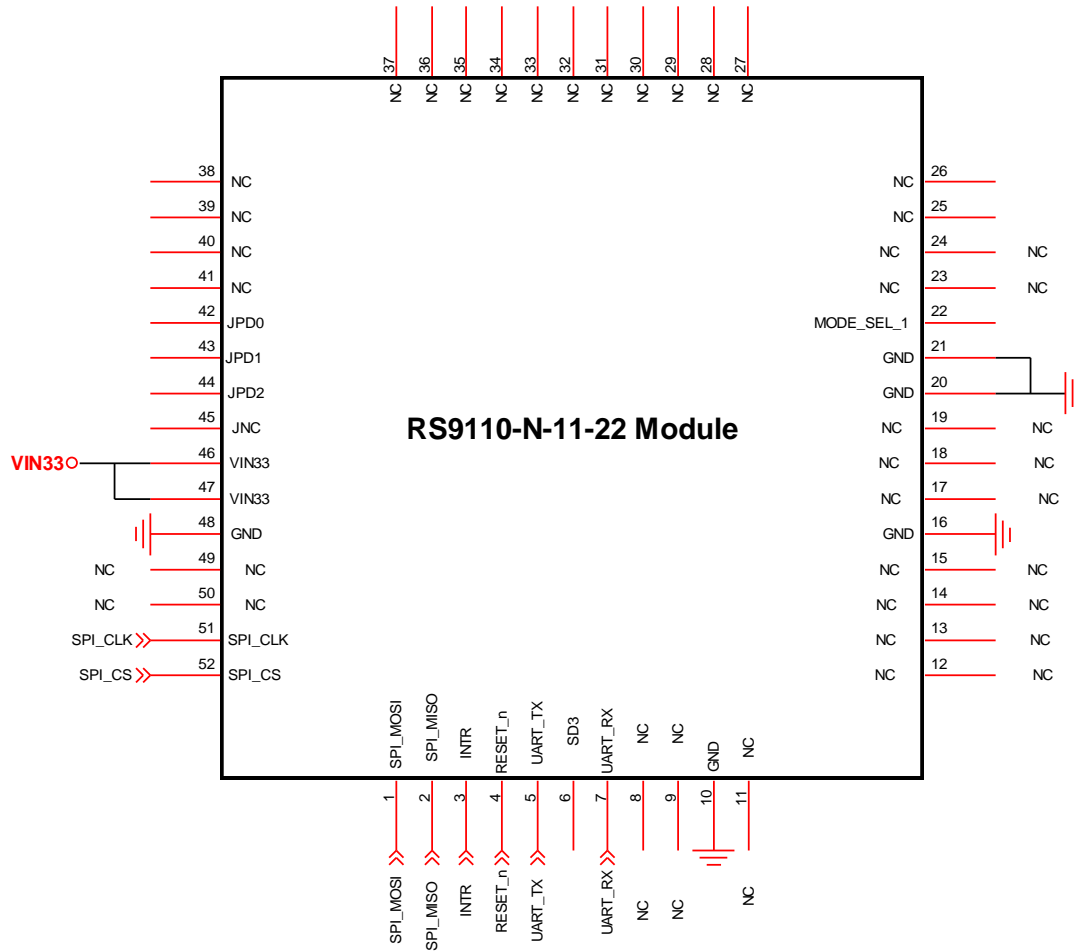

Figure 6: Pinout of the Module

3.2 Pin Description

Pin No.	Pin Name	Direction	Type	Description
1	SPI_MOSI	Input	LVC MOS 8mA	SPI Data Input. In UART mode, connect pull-down (1K to 10K Ohms)
2	SPI_MISO	Output	LVC MOS 8mA	SPI Data output. No connect in UART mode
3	INTR	Output	LVC MOS	Interrupt to the host. Active high, level

Pin No.	Pin Name	Direction	Type	Description
			8mA	triggered. Asserted by the module when: 1.The module has to transmit data to the host through SPI. 2.When the module wakes up from sleep mode
4	RESET_n	Input	LVC MOS	Power on reset. Active low, required to be active for at least 10 ms after power on, to reset the module.
5	UART_TX	Output	LVC MOS 4mA	UART output. No connect in SPI mode.
6	SD3	-		No connect in SPI mode. In UART mode, connect pull-down (1K to 10K Ohms)
7	UART_RX	Input	LVC MOS 4mA	UART input. No connect in SPI mode.
8	NC	-		No connect
9	NC	-		No connect
10	GND	Ground		Ground. Connect all the GND pins directly to a ground plane or copper ground fill
11	NC	-		No Connect
12	NC	-		No connect
13	NC	-		No connect
14	NC	-		No connect
15	NC	-		No connect
16	GND	Ground		Ground. Connect all the GND pins directly to a ground plane or copper ground fill
17	NC	-		No connect
18	NC	-		No connect
19	NC	-		No connect
20	GND	Ground		Ground. Connect all the GND pins directly to a ground plane or copper ground fill.
21	GND	Ground		Ground. Connect all the GND pins directly to a ground plane or copper ground fill
22	MODE_SEL_1	Input	LVC MOS 2mA	SPI Mode: Connect pull down (3.9K Ohms to 4.7K Ohms) UART Mode: No connect

Pin No.	Pin Name	Direction	Type	Description
23	NC	-		No connect
24	NC	-		No connect
25	NC	-		No Connect
26	NC	-		No Connect
27	NC	-		No Connect
28	NC	-		No Connect
29	NC	-		No Connect
30	NC	-		No Connect
31	NC	-		No Connect
32	NC	-		No Connect
33	NC	-		No Connect
34	NC	-		No Connect
35	NC	-		No Connect
36	NC	-		No Connect
37	NC	-		No Connect
38	NC	-		No Connect
39	NC	-		No Connect
40	NC	-		No Connect
41	NC	-		No Connect
42	JPD	-		Connect pull down of 1 K Ohms
43	JPD	-		Connect pull down of 1 K Ohms
44	JPD	-		Connect pull down of 1 K Ohms
45	JNC	-		No connect
46	VIN33	Power		3.3V Power supply, Recommend connecting these pins to a copper fill with bypassed capacitors as indicated in reference schematics. 10mV pk-pk maximum noise allowed.

Pin No.	Pin Name	Direction	Type	Description
47	VIN33	Power		3.3V Power supply, Recommend connecting these pins to a copper fill with bypassed capacitors as indicated in reference schematics. 10mV pk-pk maximum noise allowed.
48	GND	Ground		Ground. Connect all the GND pins directly to a ground plane or copper ground fill
49	NC	-		No connect
50	NC	-		No connect
51	SPI_CLK	Input	LVC MOS	SPI Clock input. In UART mode, should be pulled down with resistor (1K to 10K Ohms)
52	SPI_CS	Input	LVC MOS 8mA	Active low SPI Chip Select. In UART mode, should be pulled down with resistor (1K to 10K Ohms)

Table 1: Pin Description

Notes:

- Some interfaces are not used in the default configuration or mode of operation. These may be used in custom applications with appropriate firmware.
- Please contact Redpine Signals for application notes or for customization of a solution.

4 Electrical Characteristics

4.1 Absolute Maximum Ratings

Absolute maximum ratings in the table given below are the values beyond which the device could be damaged. Functional operation at or beyond these conditions is not guaranteed.

Parameter	Symbol	Value	Units
Input Supply voltage	V _{in}	3.6	V
Supply voltage for I/O Rail	DVDD33	3.6	V
Supply Voltage for the RF	VRF33	3.6	V
RF Input Level	RFIN	10	dBm
Storage temperature	T _{store}	-65 to 150	°C
Electrostatic discharge tolerance (HBM)	ESD _{HBM}	2000	V
Electrostatic discharge tolerance (MM)	ESD _{MM}	200	V
Electrostatic discharge tolerance (CDM)	ESD _{CDM}	500	V

Table 2: Absolute Maximum Ratings

4.2 Recommended Operating Conditions

Parameter	Symbol	Min.	Typ.	Max.	Units
Input Supply voltage	V _{IN}	3.1	3.3	3.6	V
Ambient temperature	T _a	-40	25	85	°C

Table 3: Recommended Operating Conditions

4.3 DC Characteristics – Digital I/O Signals

Parameter	Min.	Typ.	Max.	Units
Input high voltage	2	-	3.6	V
Input low voltage	-0.3	-	0.8	V
Output low voltage	-	-	0.4	V
Output high voltage	3.0	-	-	V
Input leakage current (at 3.3V or 0V)	-	-	±10	μA
Tristate output leakage current (at 3.3V or 0V)	-	-	±10	μA

Table 4: Input/Output DC Characteristics

4.4 AC Characteristics – Digital I/O Signals

4.4.1 SPI Interface

Parameter	Symbol	Min.	Typ.	Max.	Units
SPI_CLK Frequency	Fspi	0		25	MHz
SPI_CS to output valid	Tcs	3.5	-	7.5	ns
SPI CS setup time	Tcst	2	-		ns
SPI_MOSI setup time	Tsd	1	-		ns
SPI_MOSI hold time	Thd	1.5	-		ns
SPI_MISO clock to output valid	Tod	4	-	9.25	ns

Table 5: AC Characteristics – SPI Interface

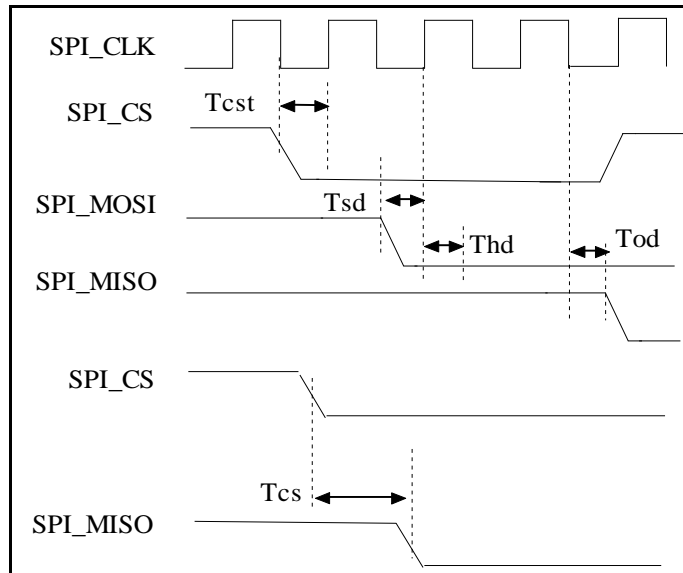

Figure 7: Interface Timings – SPI Interface

4.4.2 Reset Sequence and Timing

Following diagram shows the timing requirement for Reset_n input in two scenarios. This timing is valid for both UART and SPI based modules. The crystal oscillator output should be stable before releasing reset.

- A. Powerup
- B. Giving hard reset during module operation

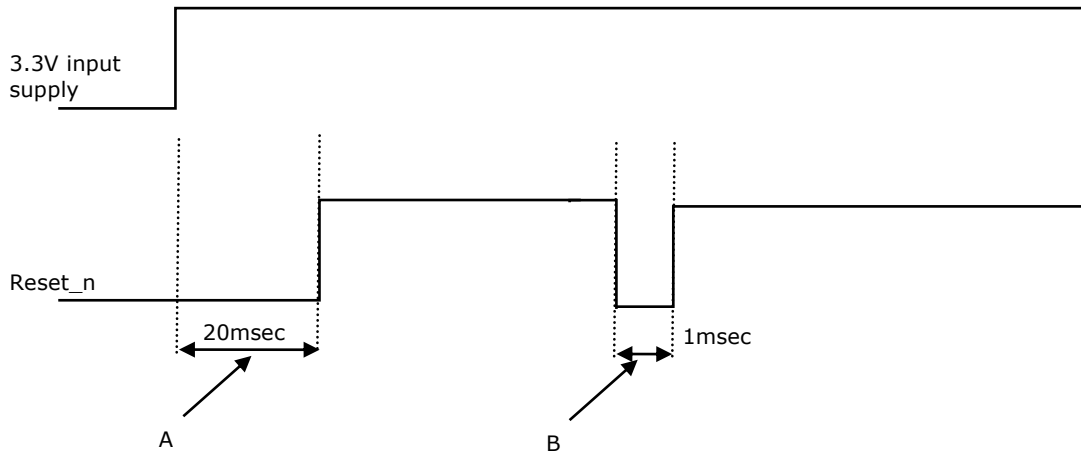

Figure 8:Reset Pin Timing Diagram

5 Performance Specifications

5.1 Wireless Specifications

Feature	Description
Frequency Band	2.400 – 2.500 GHz (2.4 GHz ISM band)
Modulation	OFDM with BPSK, QPSK, 16-QAM, and 64-QAM 802.11b with CCK and DSSS
Supported Data Rates	802.11n: 6.5, 13, 19.5, 26, 39, 52, 58.5, 65 Mbps 802.11a/g: 6, 9, 12, 18, 24, 36, 48, 54 Mbps 802.11b: 1, 2, 5.5, 11 Mbps
802.11n Features	MCS 0-7, STBC, RIFS, Greenfield Protection A-MPDU, A-MSDU Aggregation with Block-ack
Typical Transmit Power (+/- 2 dBm)	17 dBm for 802.11b DSSS 17 dBm for 802.11b CCK 15 dBm for 802.11g/n OFDM

Table 6: Wireless Specifications

5.2 Receive Sensitivity

Data Rate	Typical Sensitivity (+/- 1.5 dBm)	Sweep – PER Floor
1 Mbps	-97.0 dBm	< 0.1%
2 Mbps	-93.0 dBm	< 0.1%
11 Mbps	-88.0 dBm	< 0.1%
6 Mbps	-91.0 dBm	< 0.1%
54 Mbps	-75.0 dBm	< 0.1%
65 Mbps	-71.0 dBm	< 0.1%

Table 7: Receive Characteristics – Sensitivity

Range varies with the conditions under which wireless communication is sought. For large office environments, in the presence of obstacles, a range of over 30 metres is observed, while in open, line-of-sight environments, over 300 metres is observed, with several Mbps throughput in both cases.

5.3 Throughput

Interface	(TCP) Throughput
UART (measured at 115200 bauds per sec)	Tx – 75 kbps

Interface	(TCP) Throughput
	Rx – 72 kbps
SPI	Tx – 7.5 Mbps Rx – 6 Mbps

5.4 Standards Compliance

RS9110-N-11-22 is compliant with the requirements of IEEE 802.11b, 802.11g and 802.11n that include the following:

- Transmit Spectral Mask
- Transmit Center Frequency Leakage
- Transmit Center Frequency Accuracy
- Symbol Clock Frequency Tolerance
- Transmit Constellation error
- Receiver Adjacent Channel Interference Rejection
- Receiver Non-adjacent Channel Rejection
- Receiver Minimum Input Level
- Receiver Maximum Input Level

6 Software Architecture Overview

The following figure depicts the software architecture of the RS9110-N-11-22 module.

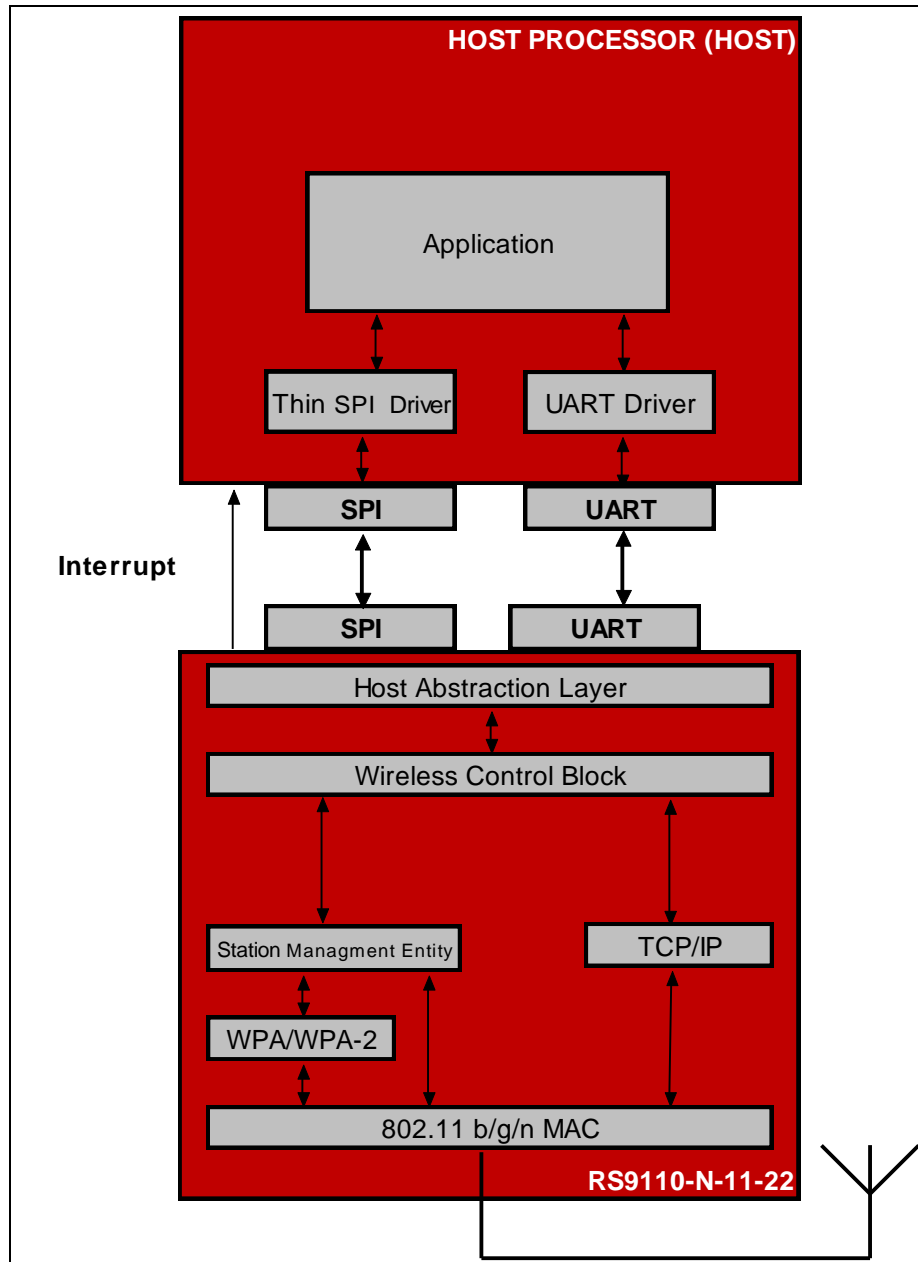

Figure 9:RS9110-N-11-22 Software Architecture Block Diagram

As shown in the figure above, the RS9110-N-11-22 module is integrated with the Host using either UART or SPI interfaces. The transmission and reception of the data to/from the Host depends on the interface used to connect the module as briefed below.

UART mode:

The Host transmits/receives raw data using UART interface when the RS9110-N-11-22 module is configured for UART mode. The access to the TCP/IP stack in the Wi-Fi module through the UART is provided through AT commands.

SPI mode:

Host transmits/receives raw data using SPI interface when the RS9110-N-11-22 module is configured for SPI mode. A thin driver on the Host takes care of interacting with the Wi-Fi module through the SPI Host interface.

The following sections explain in brief the various components illustrated in Figure 9.

6.1 Host

The Host is any system that has applications being executed and either a UART or SPI interface.

6.1.1 UART

The UART on the Host side provides an interface for the host to access the Wi-Fi module. UART is used to configure various parameters of the RS9110-N-11-22 module and also to send and receive data over the network by accessing the TCP/IP stack in the RS9110-N-11-22 module.

6.1.2 SPI

The SPI on the Host side provides an interface for the host to access the Wi-Fi module. SPI on the Host acts as the master.

6.1.3 Thin SPI Driver

The SPI driver on the Host is a thin driver through which the applications interact with the Wi-Fi module. The SPI driver uses the SPI host controller driver on the Host to send/receive the data to/from the RS9110-N-11-22 module and also to configure the same over the SPI interface.

6.2 RS9110-N-11-22

The RS9110-N-11-22 module incorporates Wi-Fi, TCP/IP, DHCP Client, ARP, etc., to act as a wireless device server. It handles all the network connectivity functions. The following sections describe the software components of the RS9110-N-11-22 module in brief.

6.2.1 SPI

The SPI on the RS9110-N-11-22 acts the SPI slave. It is a standard 4-wire SPI and can support a maximum frequency of 25MHz.

6.2.2 UART

The UART on the RS9110-N-11-22 module is the physical interface which transmits/receives the data from the Host. It supports variable baud rates from 9600 to 3686400 bps. There is support for AT commands to configure and operate the module through UART interface. Flow control is not supported.

6.2.3 Host Abstraction Layer (HAL)

The HAL abstracts the lower layers in the host interface with which the RS9110-N-11-22 module is connected. The HAL interacts with the Wireless Control Block layer for the processing of the frames obtained from or destined to the Host.

6.2.4 Wireless Control Block (WCB)

The data from/to the Host is classified as Wi-Fi specific frames and TCP/IP specific frames. The WCB layer processes the frame obtained and acts accordingly. The functionality of the WCB module depends on the type of the frame and the direction of the frame (in case of TCP/IP) as described below.

6.2.5 Wi-Fi Control Frames

The WCB interprets the Wi-Fi control information from the Host and interacts with the SME (Station Management Entity). Configuration of the RS9110-N-11-22 module from the Host for Wi-Fi access is through AT commands. The Wi-Fi AT commands set or get the values of various configurable parameters for providing the Wi-Fi access.

6.2.6 TCP/IP Control Frames

If the frames from the host are interpreted as TCP/IP specific frames then the WCB interacts with the TCP/IP stack.

6.2.7 Station Management Entity (SME)

The SME is the core layer which manages the Wi-Fi connectivity. The SME maintains the state machine to detect the activity on the Wi-Fi network and indicates to the user accordingly. It also performs re-association to the configured access point in Infrastructure mode. It interacts with the WPA supplicant if Security is enabled in the Wi-Fi network.

6.2.8 WPA Supplicant

The WPA supplicant is used to initiate the 802.1x/EAP Access Point authentication if WPA/WPA2-PSK is used as the security parameter. It also plays a major part in performing the 4-way handshake to derive the PTK in WPA/WPA2-PSK modes.

6.3 Power Save Modes

The RS9110-N-11-2X module supports three power modes. The Host can switch among the power modes depending on the Wi-Fi connection status as defined in this section.

6.3.1 Power Mode 0

In this mode, power save is disabled in the RS9110-N-11-2X module. The module will be in Power Mode 0 by default.

6.3.2 Power Mode 1

The RS9110-N-11-2X module powers off the Baseband, RF and also the Core Control Block. To power off the Core Control block, the RS9110-N-11-2X module sends request to Host for permission to sleep.

Once the permission is received the Core Control block is powered off. The Host has to wait for the module to wakeup based on the timer that is configured by the Host, before it can transmit any packets.

The functioning of the module in this mode depends on the connection status as explained below

1. Before Wi-Fi connection

In this state, the module is configured with a sleep timer. Once the timer expires, the module powers on the Core Control block and sends the request for sleep permission to the Host again. On getting permission the Host, the module will power off the Core Control block for another interval of the sleep period.

If the host wants to perform any Wi-Fi related activity like scanning or joining networks, it has to switch to Power Mode 0. After a connection is established, it can switch back to Power Mode 1 or 2.

2. After Wi-Fi Connection

In this state, the RS9110-N-11-2X module periodically wakes up to receive beacons from the Access Point (AP). If there is no data to be transmitted or received to/from the Access Point, it powers off the Baseband and RF components and requests the Host permission to turn off the Core Control block. On receiving permission from the Host, the module goes to sleep and wakes up before the next beacon comes.

6.3.3 Power Mode 2

The RS9110-N-11-2X module powers off the Baseband and RF components in this mode. The Core Control block interacting with the Host is always functional in this mode. Hence, the module can receive commands from the host at any time.

NOTE: The average current consumption in Power Mode 2 is higher than Power Mode 1.
--

The functioning of the module in this mode depends on the connection status as explained below

1. Before Wi-Fi connection

If this power mode is enabled before the Wi-Fi connection is established, the module powers off the Baseband and RF

components until the Host reconfigures the module to Power Mode 0.

If the host wants to perform any Wi-Fi related activity like scanning and joining networks, it has to switch to Power Mode 0. This can be done at any time during the operation. The Host can switch back to Power Modes 1 or 2 after the Wi-Fi connection is established.

2. After Wi-Fi Connection

In this state, the RS9110-N-11-2X module gets information from the Access Point to which it is connected for any buffered data at every beacon. If there is no data to be transmitted or received to/from the Access Point, it powers off the Baseband and RF components.

7 Ordering Information

Contact Information

For additional information, please contact Sales at Redpine Signals, Inc.

Redpine Signals, Inc.

2107 North First Street, Suite 680,

San Jose, CA 95131 USA

Phone: +1 408 748 3385

E-mail: sales@redpinesignals.com

Website: <http://www.redpinesignals.com/>

Device Ordering Information

The following table lists the part numbers to be used for ordering modules or evaluation boards (EVB). Redpine can create and provide customized firmware based on user requirements.

Device Number	Description	Packaging	Qualification
RS9110-N-11-22-0	Part with UART as Host Interface	Tray	-40 C to +85 C
RS9110-N-11-22-01-0	Part with SPI as Host Interface	Tray	-40 C to +85 C
RS9110-N-11-22-02-0	Part with UART as Host Interface and external antenna connector	Tray	-40 C to +85 C
RS9110-N-11-22-03-0	Part with SPI as Host Interface and external antenna connector	Tray	-40 C to +85 C
RS9110-N-11-22-EVB	Evaluation board with UART as Host Interface	Board	
RS9110-N-11-22-01-EVB	Evaluation board with SPI as Host Interface	Board	
RS9110-N-11-22-02-EVB	Evaluation board with UART as Host Interface and external antenna	Board	

	connector		
RS9110-N-11-22-03-EVB	Evaluation board with SPI as Host Interface and external antenna connector	Board	

Table 8: Device Ordering Information

Collateral

The following documentation and software are available along with the RS9110-N-11-22 module.

- Evaluation Board (EVB) for Serial interface
- Embedded firmware for WLAN and TCP/IP stack
- Driver software for SPI and for AT Command Interface for UART
- EVB User Guide
- Reference schematics and layout guidelines
- Programming Reference Manual

8 Command Reference (AT commands and SPI commands)

AT Command Set (for UART interface) and SPI command set (for SPI interface) supports the following in RS9110-N-11-XX module. This is an indicative list and not a full list. Full list of commands available in Programming Reference Manual.

- i. Configure the band to 2.4GHz
- ii. Initialize MAC and Baseband
- iii. Scan for available networks
- iv. Join an available network in infrastructure or ad-hoc modes
- v. Configure IP addresses
- vi. Open and close TCP and UDP sockets
- vii. Send and receive data
- viii. Soft reset
- ix. Baud rate configuration
- x. Query by host for network parameters like RSSI, IP addresses, security type etc.
