

2 POLY-CARBONMONOFLUORIDE LITHIUM BATTERIES (BR SERIES)

BR-1220

DIMENSIONS (MM)

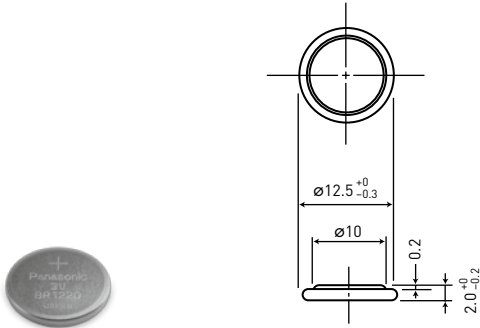

Model number	BR-1220
Nominal voltage (V)	3
Nominal capacity (mAh)	35
Diameter (mm)	12.5
Total height (mm)	2.0
Discharging temperature range (°C)	-30 to +85
Weight (g)	0.7

*Please consult Panasonic when anticipating usage in operating temperature of 80°C or above.

DISCHARGE TEMPERATURE CHARACTERISTICS

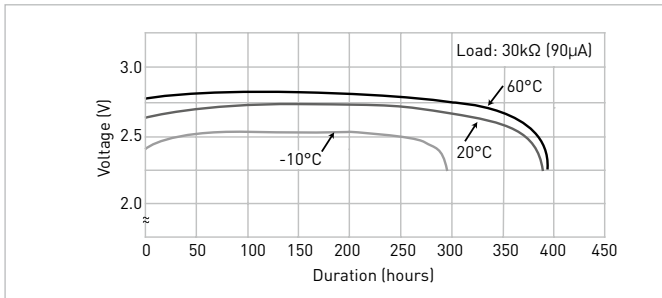

OPERATING VOLTAGE VS. DISCHARGE CURRENT*1

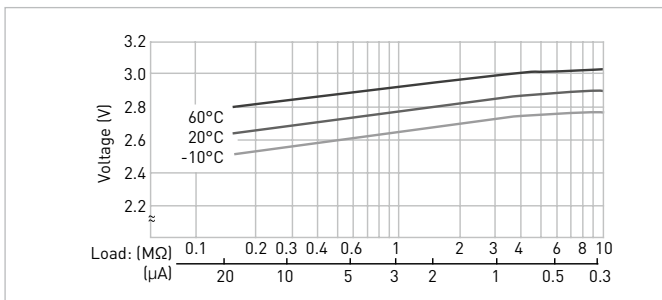

CAPACITY VS. LOAD RESISTANCE

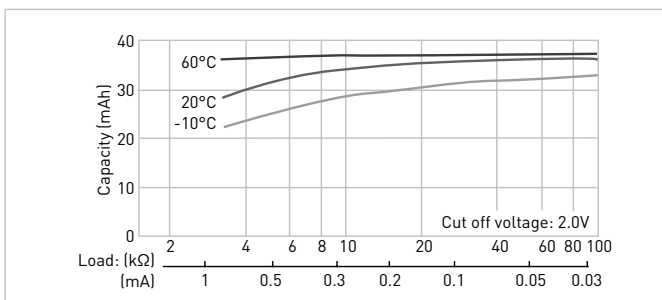

BR-1225

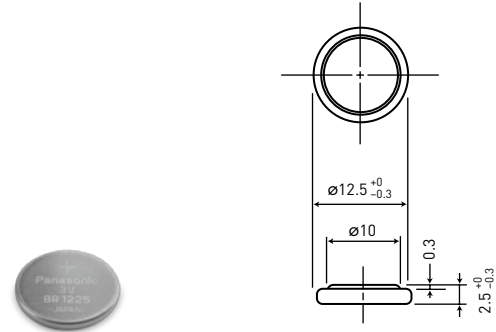

Model number	BR-1225
Nominal voltage (V)	3
Nominal capacity (mAh)	48
Diameter (mm)	12.5
Total height (mm)	2.5
Discharging temperature range (°C)	-30 to +85
Weight (g)	0.8

*Please consult Panasonic when anticipating usage in operating temperature of 80°C or above.

DISCHARGE TEMPERATURE CHARACTERISTICS

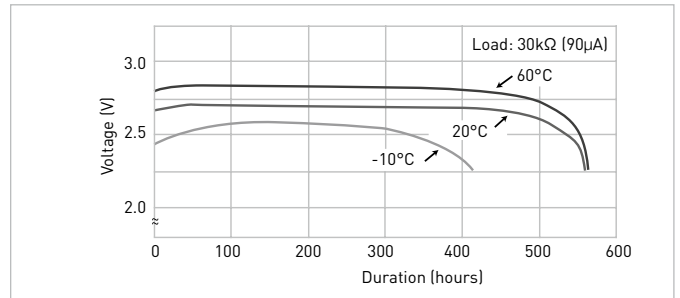

OPERATING VOLTAGE VS. DISCHARGE CURRENT*1

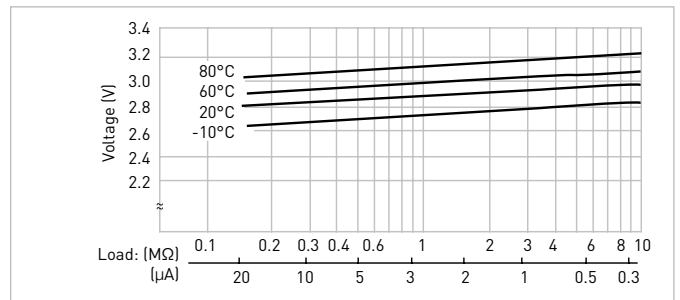

CAPACITY VS. LOAD RESISTANCE

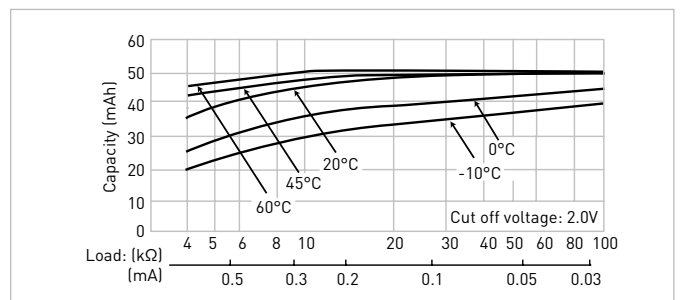

The data in this document are for descriptive purposes only and are not intended to make or imply any guarantee or warranty.