

BOARD DESCRIPTION

The AD8314 evaluation boards have been carefully laid out and tested to demonstrate the specified high speed performance of the devices. Figure 1 shows the schematic of the AD8314 MSOP evaluation board. The layout and silkscreen of the component side are shown in Figures 2 and 3. An evaluation board is also available for the CSP package. (For exact part numbers, see Ordering Guide.) Apart from the slightly smaller device footprint, the CSP evaluation board is identical to the MSOP board. The board is powered by a single supply in the range, 2.7 V to 5.5 V. The power supply is decoupled by a single 0.1 μF capacitor. Additional decoupling, in the form of a series resistor or inductor in R9, can also be added. Table I details the various configuration options of the evaluation board.

ORDERING GUIDE

Model	Package Description
AD8314-EVAL	Evaluation Board
AD8314ACP-EVAL	Evaluation Board

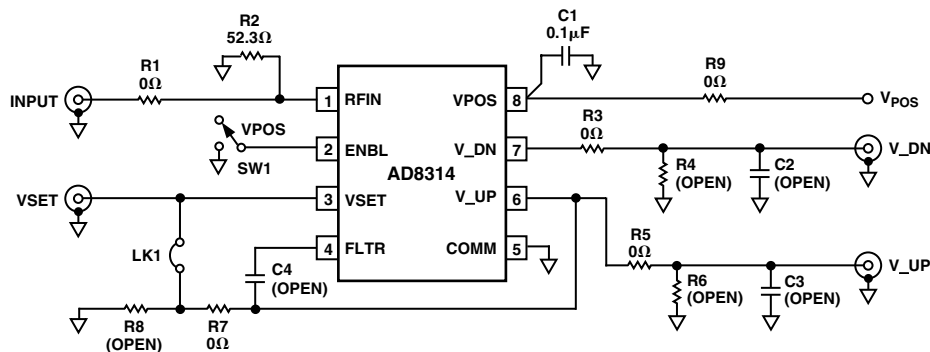

Figure 1. Evaluation Board Schematic

CAUTION

ESD (electrostatic discharge) sensitive device. Electrostatic charges as high as 4000 V readily accumulate on the human body and test equipment and can discharge without detection. Although the EVAL-AD8314EB features proprietary ESD protection circuitry, permanent damage may occur on devices subjected to high energy electrostatic discharges. Therefore, proper ESD precautions are recommended to avoid performance degradation or loss of functionality.



REV. 0

Information furnished by Analog Devices is believed to be accurate and reliable. However, no responsibility is assumed by Analog Devices for its use, nor for any infringements of patents or other rights of third parties that may result from its use. No license is granted by implication or otherwise under any patent or patent rights of Analog Devices. Trademarks and registered trademarks are the property of their respective companies.

One Technology Way, P.O. Box 9106, Norwood, MA 02062-9106, U.S.A.
 Tel: 781/329-4700 www.analog.com
 Fax: 781/326-8703 © 2003 Analog Devices, Inc. All rights reserved.

EVAL-AD8314EB

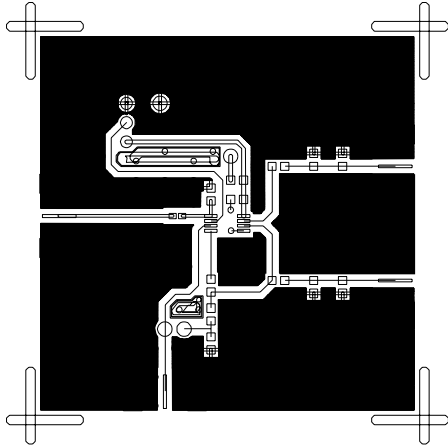

Figure 2. Layout of Component Side (MSOP)

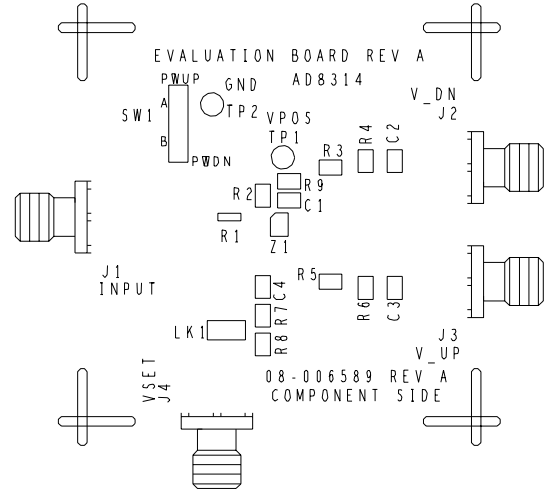

Figure 3. Silkscreen of Component Side (MSOP)

Table I. Evaluation Board Configuration Options

Component	Function	Default Condition
TP1, TP2 SW1	Supply and Ground Vector Pins Device Enable. When in position A, the ENBL pin is connected to $+V_S$ and the AD8314 is in operating mode. In Position B, the ENBL pin is grounded, putting the device in power-down mode.	Not Applicable SW1 = A
R1, R2	Input Interface. The 52.3 Ω resistor in position R2 combines with the AD8314's internal input impedance to give a broadband input impedance of around 50 Ω . A reactive match can be implemented by replacing R2 with an inductor and R1 (0 Ω) with a capacitor. Note that the AD8314's RF input is internally ac-coupled.	R2 = 52.3 Ω (Size 0603) R1 = 0 Ω (Size 0402)
R3, R4, C2, R5, R6, C3	Output Interface. R4, C2, R6, and C3 can be used to check the response of V_UP and V_DN to capacitive and resistive loading. R3/R4 and R5/R6 can be used to reduce the slope of V_UP and V_DN.	R4 = C2 = R6 = C3 = Open (Size 0603) R3 = R5 = 0 Ω (Size 0603)
C1, R9	Power Supply Decoupling. The nominal supply decoupling consists of a 0.1 μ F capacitor (C1). A series inductor or small resistor can be placed in R9 for additional decoupling.	C1 = 0.1 μ F (Size 0603) R9 = 0 Ω (Size 0603)
C4	Filter Capacitor. The response time of V_UP and V_DN can be modified by placing a capacitor between FLTR (Pin 4) and V_UP.	C4 = Open (Size 0603)
R7, R8	Slope Adjust. By installing resistors in R7 and R8, the nominal slope of 20 mV/dB can be increased. See Slope Adjust section of the AD8314 data sheet for more details.	R7 = 0 Ω (Size 0603) R8 = 0 Ω (Size 0603)
LK1	Measurement/Controller Mode. LK1 shorts V_UP to VSET, placing the AD8314 in measurement mode. Removing LK1 places the AD8314 in controller mode.	LK1 = Installed