

Evaluating the **ADL9006** 2 GHz to 28 GHz, GaAs, pHEMT, MMIC, Low Noise Amplifier

FEATURES

2-layer Rogers 4350 evaluation board with heat sink
 End launch, 2.9 mm RF connectors
 Through calibration path

EVALUATION KIT CONTENTS

ADL9006-EVALZ evaluation board

EQUIPMENT NEEDED

RF signal generator
 RF spectrum analyzer
 RF network analyzer
 5 V, 200 mA power supply
 -2.6 V to +2.6 V, 100 mA power supply

GENERAL DESCRIPTION

The ADL9006-EVALZ consists of a 2-layer printed circuit board (PCB) fabricated from 10 mil thick, Rogers 4350, copper clad, mounted to an aluminum heat sink. The heat sink assists in providing thermal relief to the device as well as mechanical support to the PCB. Mounting holes on the heat sink allow attachment to larger heat sinks for improved thermal management. The RFIN and RFOUT ports on the ADL9006-EVALZ are populated with 2.9 mm, female coaxial connectors, and the respective RF traces have a 50 Ω characteristic impedance. The ADL9006-EVALZ is populated with components suitable for use over the entire -40°C to +85°C operating temperature range of the ADL9006. To calibrate out board trace losses, a through calibration path, THRU CAL, is provided between the J5 and J6 connectors. J5 and J6 must be populated with RF connectors to use the through calibration path. The power voltages, ground voltages, gate control voltages, and detector output voltages are accessed through two 4-pin headers (see Table 1).

The RF traces are 50 Ω , grounded, coplanar waveguide. The package ground leads and the exposed paddle directly connect to the ground plane. Multiple vias are used to connect the top and bottom ground planes with particular focus on the area directly beneath the ground paddle to provide adequate electrical conduction and thermal conduction to the heat sink.

The power supply decoupling capacitors on the ADL9006-EVALZ represent the configuration used to characterize and qualify the device. It is possible to reduce the number of capacitors, but this reduction varies from system to system. It is recommended to first remove or combine the largest capacitors that are farthest from the ADL9006 when reducing the number of capacitors.

EVALUATION BOARD PHOTOGRAPHS

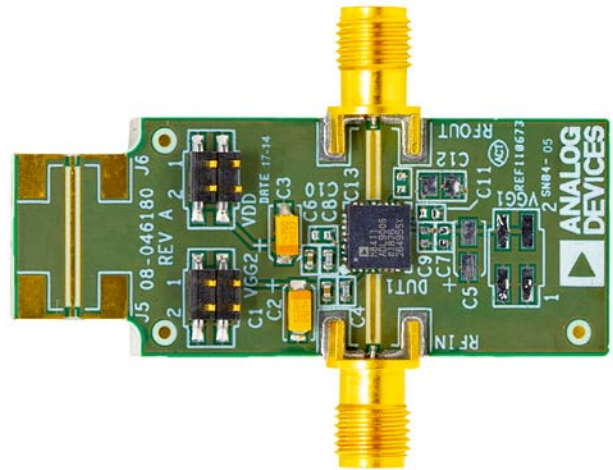

Figure 1. ADL9006-EVALZ Top Side



Figure 2. ADL9006-EVALZ Bottom Side

For full details on the ADL9006, see the ADL9006 data sheet, which must be consulted in conjunction with this user guide when using the ADL9006-EVALZ.

TABLE OF CONTENTS

Features	1	Operating the ADL9006-EVALZ	3
Evaluation Kit Contents.....	1	Through Calibration Path	3
Equipment Needed.....	1	Evaluation Board Schematic and Artwork.....	4
General Description	1	Ordering Information	5
Evaluation Board Photographs	1	Bill of Materials.....	5
Revision History	2		
Evaluation Board Hardware.....	3		

REVISION HISTORY

8/2020—Revision 0: Initial Version

EVALUATION BOARD HARDWARE

OPERATING THE ADL9006-EVALZ

A 5 V, 200 mA power supply is required to provide the main bias to the ADL9006-EVALZ. Connect the 5 V power supply to the VDD line through the VDD header.

To use the optional gain control feature, a -2.0 V to +2.6 V, 100 mA power supply is required to provide the necessary gate control voltage to VGG2. Connect the -2.0 V to +2.6 V power supply to the VGG2 line through the VGG2 header.

See the [ADL9006](#) data sheet for the bias sequencing information.

Table 1. VDD and VGG2 Header Connections to the ADL9006

Connector ¹	Header Pin	ADL9006 Mnemonic
VDD	1, 3	Ground
VDD	2, 4	V _{DD}
VGG2	1, 3	V _{GG2}
VGG2	2, 4	Ground
J5 to J6		Through calibration path (THRUCAL)

¹ See Figure 4 for more details.

THROUGH CALIBRATION PATH

Figure 3 shows the plot of the data in Table 2 of the through calibration path (J5 to J6). See Figure 4 for the evaluation board schematic.

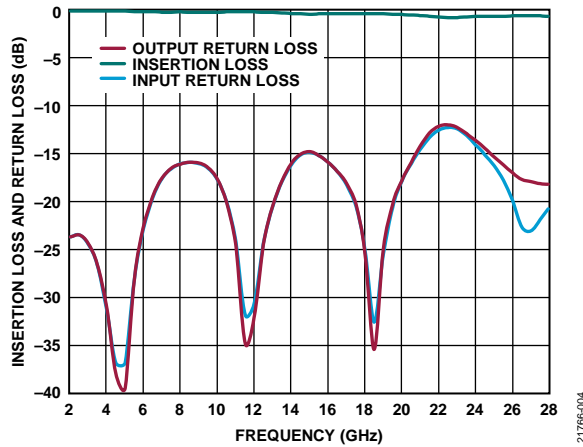

Figure 3. Insertion Loss and Return Loss of the Through Calibration Path

Table 2. Insertion Loss of the Through Calibration Path

Frequency (GHz)	Insertion Loss (dB)
2	-0.1
3	-0.1
4	-0.1
5	-0.1
6	-0.1
7	-0.2
8	-0.3
9	-0.3
10	-0.3
11	-0.3
12	-0.3
13	-0.3
14	-0.4
15	-0.5
16	-0.5
17	-0.5
18	-0.4
19	-0.5
20	-0.6
21	-0.8
22	-0.8
23	-0.8
24	-0.7
25	-0.7
26	-0.7
27	-0.7
28	-0.7

EVALUATION BOARD SCHEMATIC AND ARTWORK

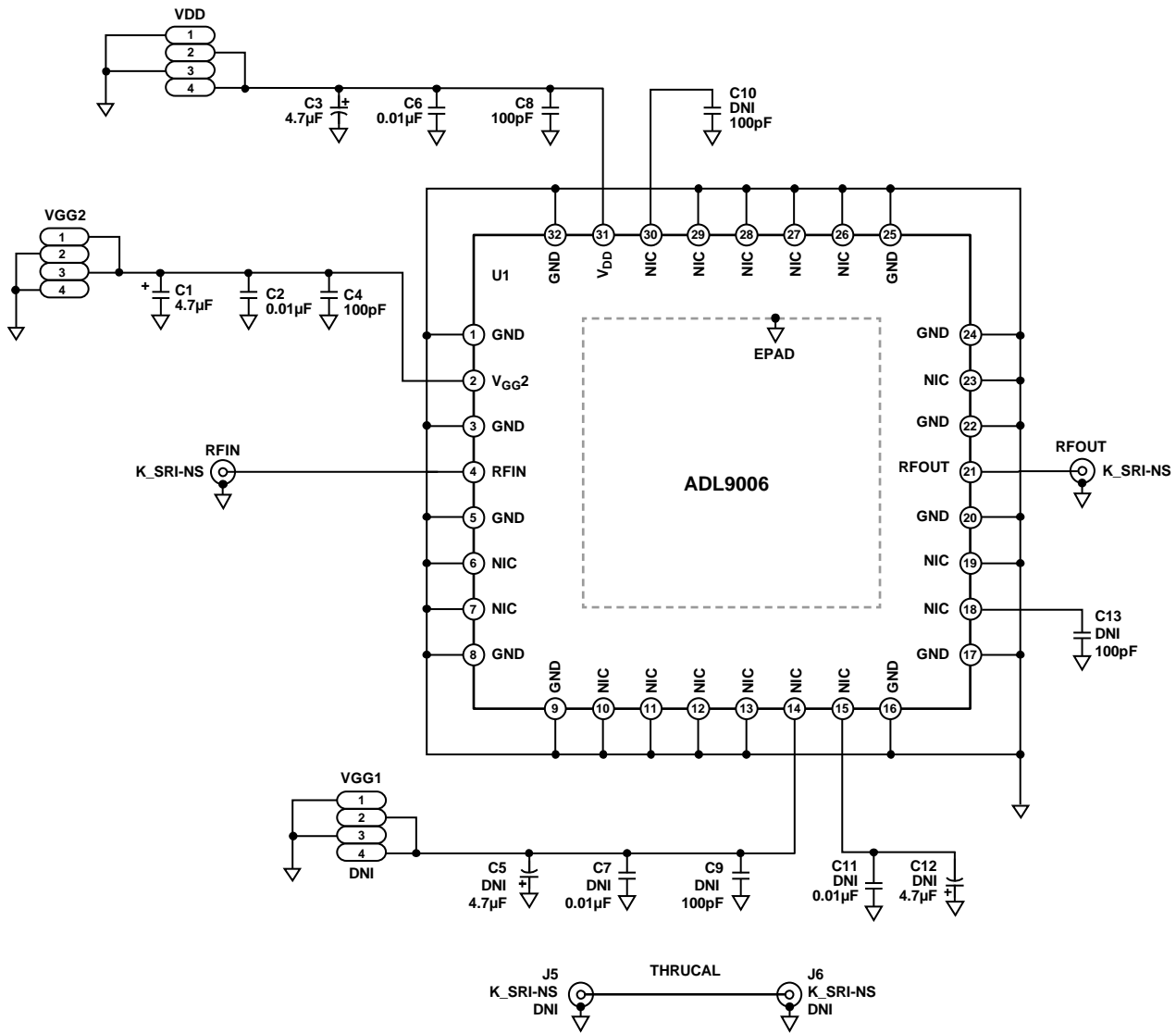

Figure 4. ADL9006-EVALZ Schematic

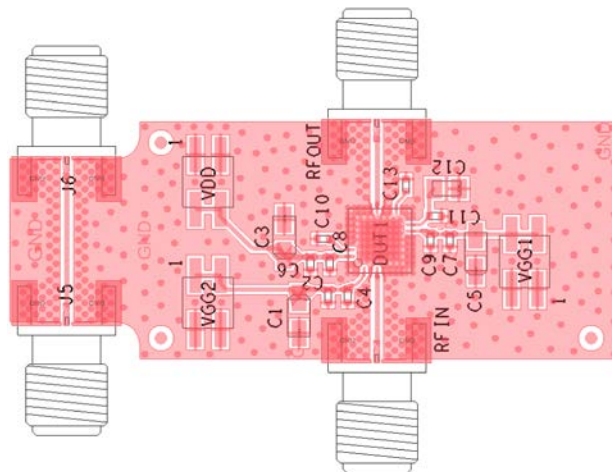

Figure 5. ADL9006-EVALZ Assembly Drawing (J5 and J6 Not Installed)

ORDERING INFORMATION

BILL OF MATERIALS

Table 3.

Reference Designator	Description	Manufacturer	Device Number
C1, C3	4.7 μ F capacitors, tantalum	AVX	TAJA475K020RNJ
C2, C6	0.01 μ F capacitors, multilayer, ceramic, XR7	Kemet	C0402C103J3RACTU
C4, C8	100 pF capacitors, multilayer, ceramic, NPO, high temperature	TDK	C1005NP01H101J050BA
J5, J6	Connectors, K jack edge, do not insert (DNI)	SRI Connector Gage Co.	25-146-1000-92
VDD, VGG2	Connectors, PCB header, unshrouded, dual row, header 4-position, 0.5 mm pitch	Molex	87759-0414
RFIN, RFOUT	Connectors, K jack edge	SRI Connector Gage Co.	25-146-1000-92
U1	Gallium arsenide (GaAs), pseudomorphic high electron mobility transistor (pHEMT), monolithic microwave integrated circuit (MMIC), 2 GHz to 28 GHz, low noise amplifier	Analog Devices, Inc.	ADL9006
Not Applicable	Aluminum heat sink (see Figure 2), dimensions of heat sink: 1.9 inch \times 0.75 inch	Not applicable	Not applicable



ESD Caution

ESD (electrostatic discharge) sensitive device. Charged devices and circuit boards can discharge without detection. Although this product features patented or proprietary protection circuitry, damage may occur on devices subjected to high energy ESD. Therefore, proper ESD precautions should be taken to avoid performance degradation or loss of functionality.

Legal Terms and Conditions

By using the evaluation board discussed herein (together with any tools, components documentation or support materials, the "Evaluation Board"), you are agreeing to be bound by the terms and conditions set forth below ("Agreement") unless you have purchased the Evaluation Board, in which case the Analog Devices Standard Terms and Conditions of Sale shall govern. Do not use the Evaluation Board until you have read and agreed to the Agreement. Your use of the Evaluation Board shall signify your acceptance of the Agreement. This Agreement is made by and between you ("Customer") and Analog Devices, Inc. ("ADI"), with its principal place of business at One Technology Way, Norwood, MA 02062, USA. Subject to the terms and conditions of the Agreement, ADI hereby grants to Customer a free, limited, personal, temporary, non-exclusive, non-sublicensable, non-transferable license to use the Evaluation Board FOR EVALUATION PURPOSES ONLY. Customer understands and agrees that the Evaluation Board is provided for the sole and exclusive purpose referenced above, and agrees not to use the Evaluation Board for any other purpose. Furthermore, the license granted is expressly made subject to the following additional limitations: Customer shall not (i) rent, lease, display, sell, transfer, assign, sublicense, or distribute the Evaluation Board; and (ii) permit any Third Party to access the Evaluation Board. As used herein, the term "Third Party" includes any entity other than ADI, Customer, their employees, affiliates and in-house consultants. The Evaluation Board is NOT sold to Customer; all rights not expressly granted herein, including ownership of the Evaluation Board, are reserved by ADI. CONFIDENTIALITY. This Agreement and the Evaluation Board shall all be considered the confidential and proprietary information of ADI. Customer may not disclose or transfer any portion of the Evaluation Board to any other party for any reason. Upon discontinuation of use of the Evaluation Board or termination of this Agreement, Customer agrees to promptly return the Evaluation Board to ADI. ADDITIONAL RESTRICTIONS. Customer may not disassemble, decompile or reverse engineer chips on the Evaluation Board. Customer shall inform ADI of any occurred damages or any modifications or alterations it makes to the Evaluation Board, including but not limited to soldering or any other activity that affects the material content of the Evaluation Board. Modifications to the Evaluation Board must comply with applicable law, including but not limited to the RoHS Directive. TERMINATION. ADI may terminate this Agreement at any time upon giving written notice to Customer. Customer agrees to return to ADI the Evaluation Board at that time. LIMITATION OF LIABILITY. THE EVALUATION BOARD PROVIDED HEREUNDER IS PROVIDED "AS IS" AND ADI MAKES NO WARRANTIES OR REPRESENTATIONS OF ANY KIND WITH RESPECT TO IT. ADI SPECIFICALLY DISCLAIMS ANY REPRESENTATIONS, ENDORSEMENTS, GUARANTEES, OR WARRANTIES, EXPRESS OR IMPLIED, RELATED TO THE EVALUATION BOARD INCLUDING, BUT NOT LIMITED TO, THE IMPLIED WARRANTY OF MERCHANTABILITY, TITLE, FITNESS FOR A PARTICULAR PURPOSE OR NON-INFRINGEMENT OF INTELLECTUAL PROPERTY RIGHTS. IN NO EVENT WILL ADI AND ITS LICENSORS BE LIABLE FOR ANY INCIDENTAL, SPECIAL, INDIRECT, OR CONSEQUENTIAL DAMAGES RESULTING FROM CUSTOMER'S POSSESSION OR USE OF THE EVALUATION BOARD, INCLUDING BUT NOT LIMITED TO LOST PROFITS, DELAY COSTS, LABOR COSTS OR LOSS OF GOODWILL. ADI'S TOTAL LIABILITY FROM ANY AND ALL CAUSES SHALL BE LIMITED TO THE AMOUNT OF ONE HUNDRED US DOLLARS (\$100.00). EXPORT. Customer agrees that it will not directly or indirectly export the Evaluation Board to another country, and that it will comply with all applicable United States federal laws and regulations relating to exports. GOVERNING LAW. This Agreement shall be governed by and construed in accordance with the substantive laws of the Commonwealth of Massachusetts (excluding conflict of law rules). Any legal action regarding this Agreement will be heard in the state or federal courts having jurisdiction in Suffolk County, Massachusetts, and Customer hereby submits to the personal jurisdiction and venue of such courts. The United Nations Convention on Contracts for the International Sale of Goods shall not apply to this Agreement and is expressly disclaimed.

©2020 Analog Devices, Inc. All rights reserved. Trademarks and registered trademarks are the property of their respective owners.
UG21766-8/20(0)



www.analog.com