

XDM2510H

Product Overview

Based on DUST Networks' SmartMesh IA-510(H)TM technology, RFM's XDM2510H module provides WirelessHART[®] compatibility, excellent communications reliability and long battery life in a wide range of industrial automation applications. The XDM2510H employs dynamic network optimization and intelligent routing to achieve carrier-class data reliability, low latency, and deterministic power management. The XDM2510H is tailored for use in battery, energy saving and loop powered devices for applications that demand robust wireless network reliability. The multi-functional interfaces of the XDM2510H gives it the flexibility to be used in a wide variety of industrial applications, from process control and data acquisition to energy management. The XDM2510H requires no embedded programming, greatly reducing the development time and cost of a wireless sensor network application. The XDM2510H is certified for unlicensed operation in the USA, Canada and Europe. The XDM2510H complies with Directive 2002/95/EC (RoHS).

**2.4 GHz
Ultra-low Power
WirelessHART
RF Transceiver
Module**

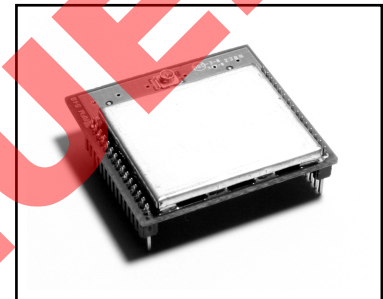

Key Features

Wireless HART Compliance

- Interoperable with WirelessHART devices

Superior Reliability

- Robust network reliability in even the most challenging industrial environments
- Frequency hopping provides interference rejection and minimizes multipath fading
- Automatic self-organizing mesh networking provides built-in network path redundancy
- Every XDM2510H acts as both an endpoint and a router, increasing network reliability

Easy Integration

- XDM2510H provides all the module functionality with no embedded programming or complex configuration requirements
- XDM2510H interfaces are well-designed and multi-functional
- Industrial temperature range -40 to +85 °C
- XDM2510HP version for plug-in installation, XDM2510HC version for solder reflow

Ultra-low Power Consumption

- Industry leading 2.4 GHz radio technology is optimized for battery, energy scavenging or loop powered operation
- Ultra-efficient power usage, enabled through SmartMesh Intelligent Network management, delivers over a decade of network operation on two AA batteries
- Automatic network-wide coordination for efficient power usage

Pre-certified Module

- IEEE 802.15.4 compliant module operates in the 2.4 GHz global license-free band
- XDM2510H is pre-certified for operation in the USA, Canada and Europe

Applications

- Industrial Automation
- Process Control and Data Acquisition
- Machine Health Monitoring
- Structural Integrity Monitoring
- Energy Management

Table of Contents

1.0 XDM2510H Introduction	3
2.0 Absolute Maximum Ratings.....	5
3.0 Normal Operating Conditions	5
3.1 Current Consumption.....	5
4.0 Electrical Specifications.....	6
4.1 Digital I/O Load	6
4.2 Digital I/O Type 1	6
4.3 Digital I/O Type 2	6
4.4 Digital I/O Type 3	7
5.0 RF Specifications	7
5.1 Radio Specifications	7
5.2 Antenna Specifications	8
6.0 Module Pinout	9
7.0 Boot Sequence	10
8.0 Hardware Interfaces	10
8.1 /RESET IN	10
8.2 /TIME	10
8.3 /LED	11
8.4 Settable I/O Modes	11
8.4.1 Mode1 - Three/Four/Five Signal Serial Interface (9600 b/s).....	11
8.4.2 Mode 3 - Five Signal Serial Interface (9600 b/s).....	12
8.4.3 UART Timing Values.....	13
8.5 Serial API	15
8.6 Temperature Sensor	15
9.0 XDM2510H Outline Drawings	16
9.1 XDM2510HP Pinned Configuration.....	16
9.2 XDM2510HC Castellated Pad Configuration.....	16

DISCONTINUED

1.0 XDM2510H Introduction

RFM's XDM2510H is a 2.4 GHz IEEE 802.15.4 WirelessHART compliant radio module designed to provide excellent communications reliability and long battery life in a wide range of industrial automation applications. The XDM2510H employs DUST Networks' SmartMesh IA-510(H)TM technology which blends the reliability of self-organizing and self-healing mesh networking with synchronized power duty cycling to achieve very long battery life operation. The XDM2510H is certified for unlicensed operation in the USA, Canada and Europe. An example XDM2510H network is shown in Figure 1. The network consists of an XG2510HE or equivalent WirelessHART gateway/network manager and XDM2510H-based sensor nodes. The XG2510HE provides both the XDM2510H network management function and the gateway application interfaces. The XG2510HE includes an Ethernet port that supports XML-based network commands, and two RS232 serial ports that support binary string network commands, diagnostics, etc.

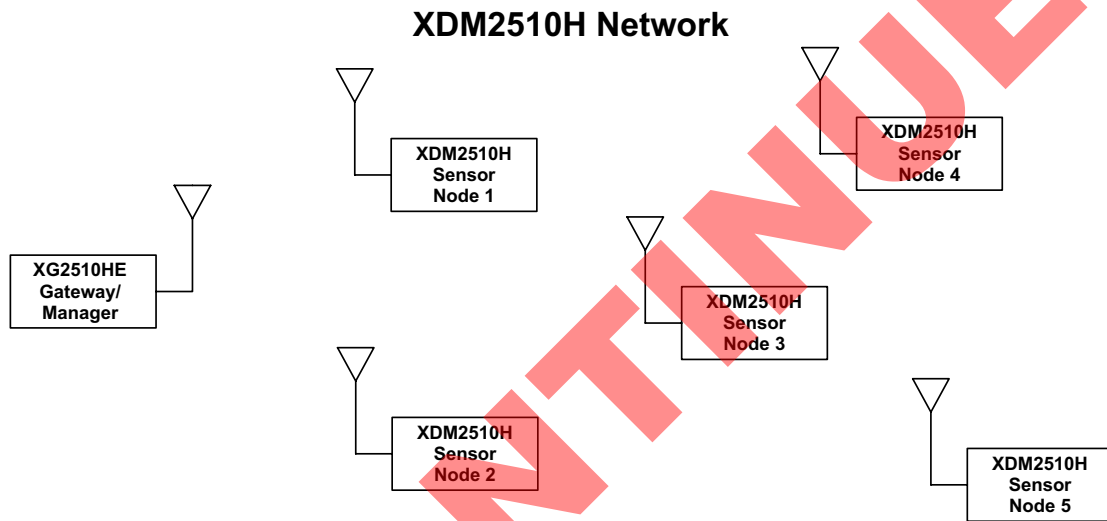

Figure 1

SmartMesh IA-510(H)TM traffic is organized into TDMA frames consisting of 10 ms time slots. The XG2510HE assigns time slots to each XDM2510H node in the network, and then maintains a precise report interval (frame-to-frame period) to provide a highly synchronized network. Network operation also hops from channel to channel in a pseudorandom pattern to mitigate the effects of multipath fading and narrowband interference. The XDM2510H monitors performance on each channel and will temporarily discontinue the use of a channel that is showing poor performance statistics.

Mesh networking allows traffic to be passed from XDM2510H node-to-node so that messages can be delivered to and from nodes that can not communicate directly with the XG2510HE gateway/manager. At least two paths are maintained by the network for communication between each node and the gateway/manager. As needed, new paths will be automatically established to replace a failing paths to maintain network performance.

As shown in Figure 2, each sensor node in the network consists of an XDM2510H radio module and a host microcontroller with sensor I/O electronics. The host microcontroller communicates with the XDM2510H radio module on a serial interface using binary command and response strings.

Typical XDM2510H Application

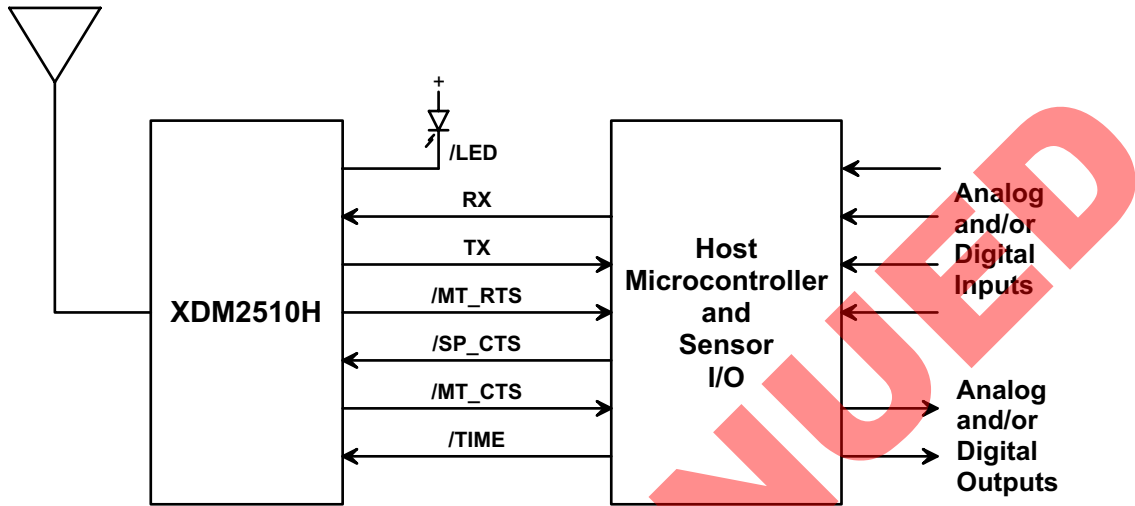

Figure 2

RFM's XDM2510H delivers the WirelessHART compatibility, exceptional network reliability and ultra-low power operation capabilities of SmartMesh IA-510(H)TM technology in a fully functional, pre-certified radio module that is easily interfaced to a wide variety industrial automation applications.

2.0 Absolute Maximum Ratings

The ratings below should not be exceeded under any circumstances. Damage can be caused by exceeding one or more of these parameters.

Parameter	Minimum	Typical	Maximum	Units	Comments
Supply Voltage	-0.3		5.5	V	
Voltage on any Digital I/O Pin	-0.3		3.6	V	
Input RF Level			10	dBm	input power at antenna connector
Storage Temperature Range	-40		+85	°C	
Solder Reflow Profile			+245	°C	for 10 seconds
VSWR of Antenna			3:1		
ESD Protection					
Antenna Port			±250	V	HBM
All Other I/O			±2	kV	HBM
			±200	V	CDM

* All voltages are referenced to module ground

Caution! This is an ESD sensitive device. Use proper ESD handling procedures when working with the device to prevent permanent damage.

Table 1

3.0 Normal Operating Conditions

Parameter	Minimum	Typical	Maximum	Units	Comments
Operational Supply Voltage Range (between V_{DD} and V_{SS})	2.85	3.60	5.50	V	including noise and load regulation
Voltage Supply Noise			100	mV _{p-p}	50 Hz to 2 MHz
Operating Temperature Range	-40		+85	°C	
Maximum Allowed Ambient Temperature Ramp During Operation			8	°C/min	-40 °C to +85 °C
Operating Relative Humidity	10		90	% RH	non-condensing

Unless otherwise noted, V_{DD} is 3.6 V and temperature is -40 °C to +85 °C.

Table 2

3.1 Current Consumption

Parameter	Minimum	Typical	Maximum	Units	Comments
Transmit		18		mA	
Receive		6		mA	
Sleep		8.5		µA	

Table 3

4.0 Electrical Specifications

4.1 Digital I/O Load

Parameter	Minimum	Typical	Maximum	Units	Comments
Total capacitance			0.5	μF	
Total inductance			84	nH	

Unless otherwise noted, V_{DD} is 3.6 V and temperature is -40 °C to +85 °C.

Table 4

4.2 Digital I/O Type 1

Digital Signal	Minimum	Typical	Maximum	Units	Comments
V_{IL} (low-level input voltage)	-0.3		0.6	V	
V_{IH} (high-level input voltage)	2.7		3.6	V	
V_{OL} (low-level output voltage)			0.4	V	
V_{OH} (high-level output voltage)	2.4			V	
Digital current*					
Output source (single pin)		3.7		mA	25 °C
Output sink (single pin)		2.0		mA	25 °C
Input leakage current		50		nA	

* This current level guarantees that the output voltage meets V_{OH} and V_{OL} specifications above.

Table 5

4.3 Digital I/O Type 2

Digital Signal	Minimum	Typical	Maximum	Units	Comments
V_{IL} (low-level input voltage)	-0.3		0.6	V	
V_{IH} (high-level input voltage)	2.7		3.6	V	
V_{OL} (low-level output voltage, multi-function I/O configured as output)	0		0.6	V	$I_{OL} < 0.6$ mA, 85 °C
V_{OH} (high-level output voltage, multi-function I/O configured as output)	2.7		3.3	V	$I_{OH} > -0.4$ mA, 85 °C
Digital current*					
Output source (single pin, multi-function I/O configured as output)		0.4		mA	25 °C
Output sink (single pin, multi-function I/O configured as output)		0.6		mA	25 °C
Input leakage current		50		nA	25 °C

* This current level guarantees that the output voltage meets V_{OH} and V_{OL} specifications above.

Table 6

4.4 Digital I/O Type 3

Digital Signal	Minimum	Typical	Maximum	Units	Comments
V _{IL} (low-level input voltage)	-0.3		0.6	V	
V _{IH} (high-level input voltage)	2.0		3.6	V	
V _{OL} (low-level output voltage)			0.4	V	
V _{OH} (high-level output voltage)	3.1			V	
Digital current*					
Output source (single pin)		100		μA	25 °C
Output sink (single pin)		1.6		mA	25 °C
Input leakage current		50		nA	25 °C

* This current level guarantees that the output voltage meets V_{OH} and V_{OL} specifications above.

Table 7

5.0 RF Specifications

5.1 Radio Specifications

Parameter	Minimum	Typical	Maximum	Units	Comments
Operating frequency	2.4000		2.4835	GHz	
Number of channels		15			
Channel separation		5		MHz	
Occupied channel bandwidth		2.7		MHz	at -20 dBc
Frequency accuracy	-40		+40	ppm	
Modulation					IEEE 802.15.4 DSSS
Raw data rate		250		kbps	
Receiver operating maximum input level		0		dBm	
Receiver sensitivity		-92.5		dBm	At 50% PER, V _{DD} = 3.6 V, 25 °C
		-90.0		dBm	At 1% PER, V _{DD} = 3.6 V, 25 °C
Output power, conducted		+8		dBm	V _{DD} = 3.6 V, 25 °C

Table 8

5.2 Antenna Specifications

The antenna must meet the specifications in Table 9 below. When the XDM2510H is placed inside an enclosure, the antenna should be mounted such that the radiating portion of the antenna protrudes from the enclosure, with the antenna connected to the module using a coaxial cable. For optimum performance, position the antenna vertically when installed. The XDM2510H has been FCC certified as a module with both a dipole antenna and a patch antenna. Any 2.4 GHz dipole antenna or 2.4 GHz patch antenna with a gain less than or equal to 12 dBi may be used without the need for any FCC type acceptance testing. If a different antenna type or a higher gain dipole or patch is to be used, please contact RFM Technical Support for more information.

Antenna Parameter	Value
Frequency range	2.4000 - 2.4835 GHz
Impedance	50 ohms
Maximum VSWR	3:1

Table 9

DISCONTINUED

6.0 Module Pinout

Pin	Name	I/O Type	Description
1	GND	-	Connect to the host circuit board ground.
2	NC	-	Leave unconnected.
3	NC	-	Leave unconnected.
4	NC	-	Leave unconnected.
5	UART_TX	Type 2 Output	Serial data output from the XDM2510H module UART.
6	UART_RX	Type 2 Input	Serial data input to the XDM2510H module UART.
7	/MT_RTS	Type 2 Output	Active low output to the host signaling the XDM2510H has a packet to deliver.
8	MODE	Type 2 Input	Mode B input, normally grounded.
9	NC	-	Leave unconnected.
10	/SP_CTS	Type 2 Input	Active low input from the host signaling it is ready to receive a packet.
11	/TIME	Type 2 Input	Active low input to trigger the XDM2510H to send a timestamp packet.
12	/MT_CTS	Type 1 Output	Active low clear to send output from XDM2510H to the host.
13	NC	-	Leave unconnected.
14	VBAT	Power	Power supply input, +2.85 to +5.5 V
15	GND	-	Connect to the host circuit board ground.
16	GND	-	Connect to the host circuit board ground.
17	/RESET IN	Type 1 Input	Active low XDM2510H reset input.
18	/LED	Type 1 Output	Active low status LED driver output.
19	NC	-	Leave unconnected.
20	NC	-	Leave unconnected.
21	NC	-	Leave unconnected.
22	NC	-	Leave unconnected.
23	NC	-	Leave unconnected.
24	NC	-	Leave unconnected.
25	NC	-	Leave unconnected.
26	NC	-	Leave unconnected.
27	NC	-	Leave unconnected.
28	GND	-	Connect to the host circuit board ground.
29	NC	-	Leave unconnected.
30	GND	-	Connect to the host circuit board ground.
-	Connector	RF	U.FL coaxial antenna connector.

Table 10

7.0 Boot Sequence

Following the active low assertion of /RESET IN, the XDM2510H completes its boot-up process by loading and decrypting the application image and loading the operating parameters. During the boot process, the modules output signals are not actively driven and the input signals are ignored. The duration of the boot process is defined in Table 10.

Boot Parameter	Minimum	Typical	Maximum	Units	Comments
t_{boot_delay}			6	s	The time between power up and serial interface availability

Table 11

8.0 Hardware Interfaces

8.1 /RESET IN

When this signal is asserted low, the XDM2510H is hardware reset until the signal is de-asserted. Note that the XDM2510H may also be reset using the reset serial command. If a system is designed to assert /RESET IN after the XDM2510H has completed its boot process, it is recommended the module be placed into deep sleep prior to assertion of the /RESET IN signal.

8.2 /TIME

The XDM2510H has the ability to deliver network-wide synchronized timestamps. The XDM2510H sends a time packet through its serial interface when one of the following occurs:

- HDLC request for time is received.
- Active-low /TIME signal is asserted.

Use of the /TIME input is optional but has the advantage of being more accurate. The value of the timestamp is taken within approximately 1 ms of receiving a /TIME signal assertion. The XDM2510H will send the time packet to the local host microcontroller within 100 ms of the strobe. If the HDLC request is used, due to packet processing the value of the timestamp may be captured several milliseconds after receipt of the packet. The real time delivered to the sensor processor is relative to the real-time clock on the Network Manager, which serves as the Network Real Time Clock (NRTC).

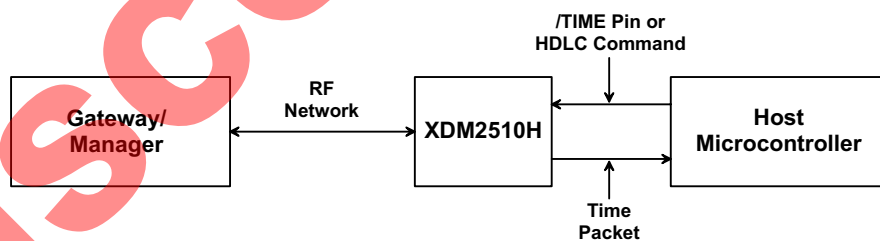

Figure 3

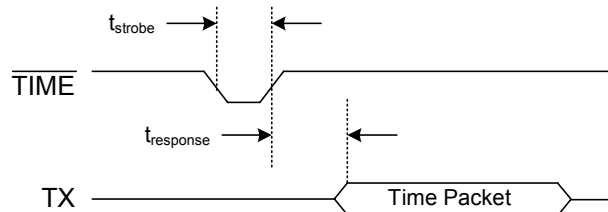

Figure 4

/TIME Parameters	Meaning	Minimum	Maximum	Units
t _{strobe}	TIME strobe pulse width	125		μs
t _{response}	TIME strobe active low assertion to start of time packet		100	ms

Table 12

8.3 /LED

The XDM2510H provides an output to drive a status LED. This signal indicates network connectivity information, which is useful during XDM2510H system installation. Alternatively, the XDM2510H status may be polled using the serial Get Parameter request with the module state parameter.

/LED Signal Behavior	XDM2510H State
High	Off, or in sleep mode
Single blink (750 ms low, 3 s high)	On, and searching for potential network
Double blink (750 ms low, 750 ms high, 750 ms low, 3 s high)	On, and attempting to join the network
Triple blink (750 ms low, 750 ms high, 750 ms low, 750 ms high, 750 ms low, 3 s high)	On, and attempting to establish redundant links
Low	On, fully configured into network with redundant parents

Table 13

8.4 Settable I/O Modes

The XDM2510H offers a choice of two I/O modes. The functionality of the interface will be determined by the setting MODE input.

MODE Pin Setting	Mode 1	Mode 3
Setting	Externally tied low	Externally tied high

Table 14

Both modes provide a means of transmitting and receiving serial data through the wireless network, and a command interface that provides synchronized time stamping, local configuration and diagnostics. Mode 1 implements an 8-bit, no parity, 9600 baud, three, four or five-signal serial interface with bidirectional packet-level flow control operating at 9600 b/s. In certain designs, one or two of the serial handshake signals may be optional for reduced pin count. Please refer to detailed descriptions of signals. Mode 3 implements an 8-bit, no parity, 9,600 baud, five-signal serial interface with bidirectional packet-level flow control and byte-level flow control in the XDM2510H-to-microcontroller direction only.

8.4.1 Mode 1 - Three/Four/Five Signal Serial Interface (9600 b/s)

XDM2510H Mode 1 provides a three, four, or five-signal serial interface optimized for low-powered embedded applications, and in certain designs may provide a lower pin count serial solution. The Mode 1 serial interface is comprised of the data pins UART_TX and UART_RX, with handshake pins /MT_RTS, /MT_CTS, /SP_CTS used for bidirectional flow control. The /MT_RTS signal is ideal for designs where the host microcontroller requires extra time to prepare to receive a packet. For example, when the host microcontroller sleeps periodically and requires a wake-up signal prior to receiving a packet. Refer to Table 15 for information on each pin, including details on which pins are optional.

Mode 1 Pin Usage

Pin	I/O	Usage
UART_RX	Input	Serial data moving from the microcontroller to the XDM2510H.
UART_TX	Output	Serial data moving from the XDM2510H to the microcontroller.
/MT_RTS	Output	/MT_RTS provides a mechanism to wake the microcontroller in order to receive a packet. /MT_RTS is asserted when the XDM2510H is ready to send a serial packet. The signal stays low until the /SP_CTS signal from the microcontroller is detected low by the XDM2510H, indicating readiness to receive a packet, or the $t_{MT_RTS\ to\ SP_CTS}$ timeout defined in Section 8.4.3 expires. If /MT_RTS times out, it will de-assert /MT_RTS, wait for $t_{MT_RTS\ retry}$ and then re-assert /MT_RTS to attempt to send the packet again. /MT_RTS may be ignored by the microcontroller only if /SP_CTS always stays low.
/SP_CTS	Input	/SP_CTS provides <i>packet level</i> flow control for packets transferred from the XDM2510H to the microcontroller. When the microcontroller is capable of receiving a packet it should assert the /SP_CTS signal. /SP_CTS may be externally tied low (reducing pin count) only if the microcontroller is always ready to receive a serial packet.
/MT_CTS	Output	/MT_CTS provides <i>packet level</i> flow control for packets transferred from the microcontroller to the XDM2510H that are destined for transfer over the network. Upon reset, following boot the XDM2510H will negate /MT_CTS until the XDM2510H establishes a wireless network connection. During operation, the XDM2510H will negate /MT_CTS if the XDM2510H does not have sufficient buffering to accept another packet. /MT_CTS will also remain high if the XDM2510H is not part of the network. The microcontroller must check that the /MT_CTS pin is low before initiating each serial packet for wireless transmission. Note that the XDM2510H may receive local serial packets at any time regardless of the /MT_CTS state.
/TIME	Input	The /TIME pin can be used for triggering a timestamp packet. Its usage is optional.

Table 15

8.4.2 Mode 3 - Five Signal Serial Interface (9600 b/s)

The XDM2510H Mode 3 provides a five-signal serial interface with *byte-level* flow control on transfers from the XDM2510H to the microcontroller. The Mode 3 serial interface consists of data pins UART_TX and UART_RX, with handshake pins /MT_RTS, /MT_CTS and /SP_CTS used for bidirectional flow control. The /MT_RTS signal is ideal for designs where the microcontroller requires extra time to prepare to receive a packet. For example, the host microcontroller sleeps periodically and requires a wake-up signal prior to receiving a packet). Refer to Table 16 for information on each handshake pin, including details on which of those pins are optional.

Mode 3 Pin Usage

Pin	I/O	Usage
UART_RX	Input	Serial data moving from the microcontroller to the XDM2510H.
UART_TX	Output	Serial data moving from the XDM2510H to the microcontroller.
/MT_RTS	Output	/MT_RTS provides a mechanism to wake the microcontroller in order to receive a packet. /MT_RTS is asserted when the XDM2510H is ready to send a serial packet. The signal stays low until the /SP_CTS signal from the microcontroller is detected low by the XDM2510H indicating readiness to receive a packet, or the $t_{MT_RTS\ to\ SP_CTS}$ timeout defined in Section 8.4.3 expires. If /MT_RTS times out, it will de-assert /MT_RTS, wait for $t_{MT_RTS\ retry}$ and then re-assert /MT_RTS to attempt to send the packet again.
/SP_CTS	Input	/SP_CTS provides both <i>packet level</i> and <i>byte level</i> flow control for packets transferred from the XDM2510H to the microcontroller. When the microcontroller is capable of receiving a packet it should assert the /SP_CTS signal. In Mode 3, byte-level flow control is achieved by having the microcontroller de-assert and then re-assert the /SP_CTS signal following the receipt of each byte. The XDM2510H will begin transmission of the next byte after detecting the re-assertion of /SP_CTS.
/MT_CTS	Output	/MT_CTS provides <i>packet level</i> flow control for packets transferred from the microcontroller to the XDM2510H that are destined for transfer over the network. Upon reset, following boot the XDM2510H will negate /MT_CTS until the XDM2510H establishes a wireless network connection. During operation, the XDM2510H will negate /MT_CTS if the XDM2510H does not have sufficient buffering to accept another packet. /MT_CTS will also remain high if the XDM2510H is not part of the network. The microcontroller must check that the /MT_CTS pin is low before initiating each serial packet for wireless transmission. Note that the XDM2510H may receive local serial packets at any time regardless of the /MT_CTS state.
/TIME	Input	The /TIME pin can be used for triggering a timestamp packet. Its usage is optional.

Table 16

8.4.3 UART Timing Values

Variable	Meaning	Minimum	Maximum	Units
t_{RX_BAUD}	Deviation from baud rate	-2	+2	%
t_{RX_STOP}	Number of stop bits, 9600 b/s	1		bit period
t_{RX_STOP}	Number of stop bits, 115.2 kb/s	1.5		bit period
t_{TX_BAUD}	Deviation from baud rate	-1	+1	%
t_{TX_STOP}	Number of stop bits	1		bit period
$t_{SP_CTS\ to\ MT_RTS}$	Assertion of /SP_CTS to negation of /MT_RTS	0	10	ms
$t_{MT_RTS\ to\ SP_CTS}$	Assertion of /MT_RTS to assertion of /SP_CTS		500	ms
$t_{MT_RTS\ retry}$	Time from a /MT_RTS timeout to the retry		500	ms
$t_{SP_CTS\ to\ TX}$	Assertion of /SP_CTS to start of byte	0	10	ms
$t_{TX\ to\ SP_CTS}$	Start of byte to negation of /SP_CTS	1		bit period
$t_{SP_CTS\ ack\ PW}$	Negation pulse width of /SP_CTS	500		ns
$t_{diag_ack_timeout}$	The XDM2510H responds to all requests within this time.		125	ms
$t_{interbyte_timeout}$	Falling edge of TX to falling edge of /SP_CTS (Mode 3 only)		7.1	ms
$t_{interpacket_delay}$	The sender of an HDLC packet must wait at least this amount of time before sending another packet	20		ms

Table 17

Power-on Sequence

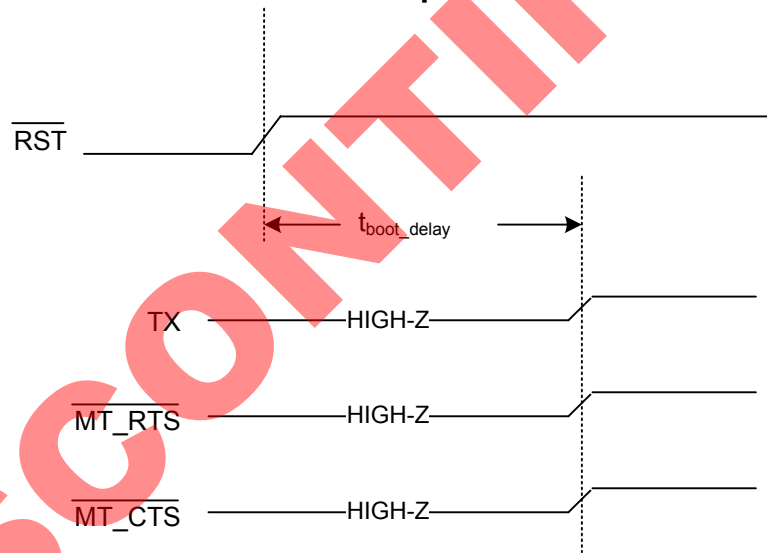

Figure 5

Byte-level Timing

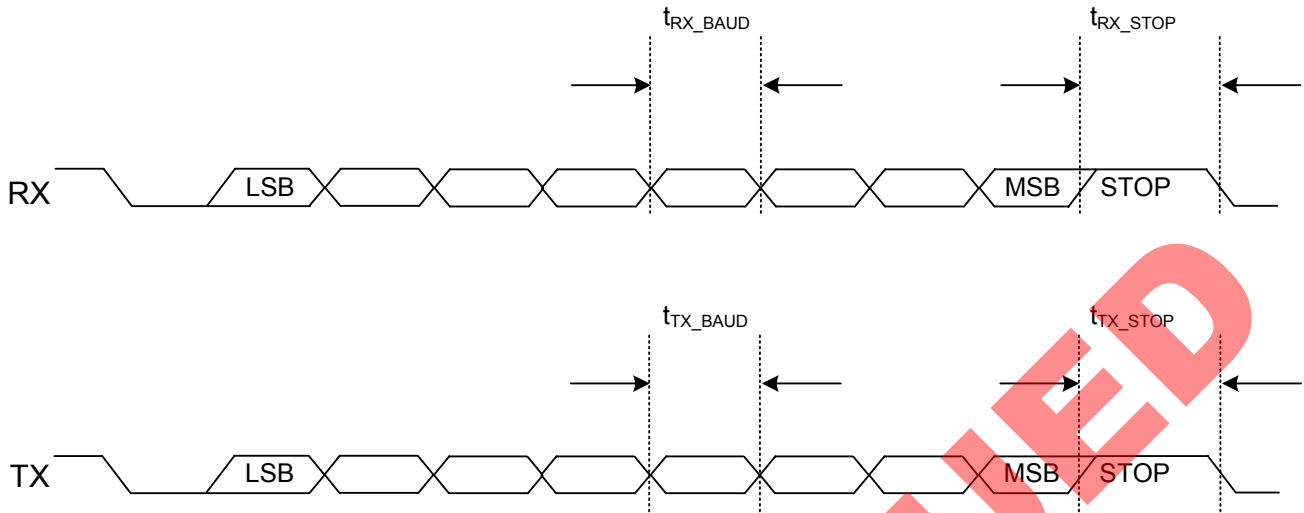

Figure 6

Flow Control Timing

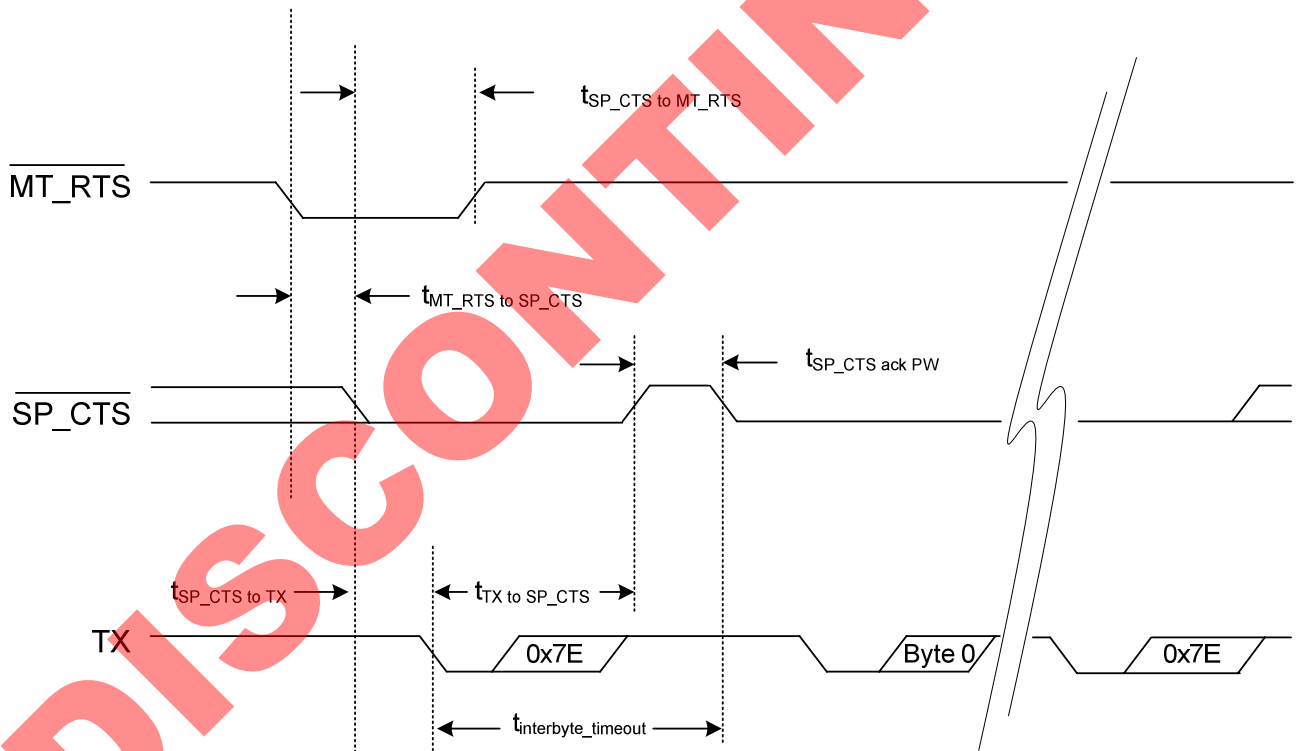

Figure 7

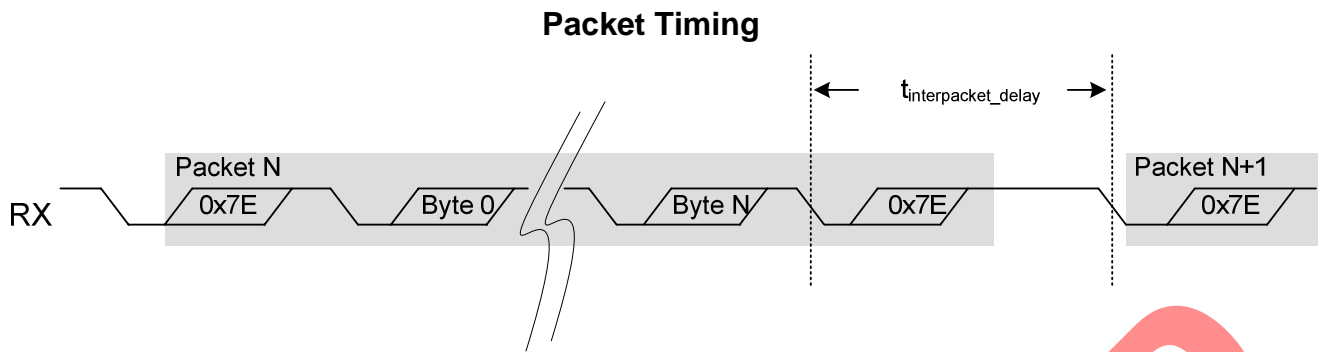

Figure 8

8.5 Serial API

The XDM2510H offers a comprehensive application programming interface (API) that provides full programmatic access to control the mote, monitor its status (such as battery charge and network status), and provide access to the wireless mesh network. Refer to the *XDM2510H Module Serial API Guide* for more information.

8.6 Temperature Sensor

The XDM2510H has an on-board temperature sensor. The temperature readings are available locally through the mote serial API and through the network at the manager via the XML or serial API. For more information, refer to the *XDM2510H Module Serial API Guide*, *XG2510HE Gateway/Manager Serial API Guide*, or *XG2510HE Gateway/Manager XML API Guide*.

Parameter	Minimum	Typical	Maximum	Units	Comments
Temperature Sensor Input Range	-40		85	°C	
Temperature Sensor Accuracy		±7		°C	

Table 18

9.0 XDM2510H Outline Drawings

9.1 XDM2510HP Pinned Configuration (dimensions in inches)

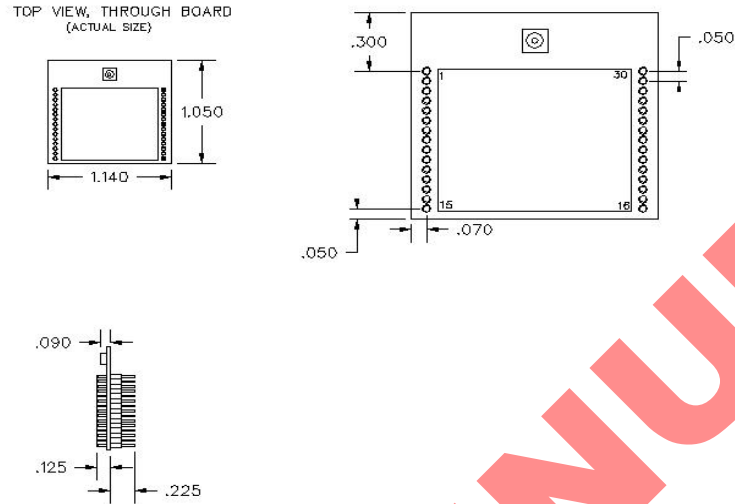

Figure 9

9.2 XDM2510HC Castellated Pad Configuration (dimensions in inches)

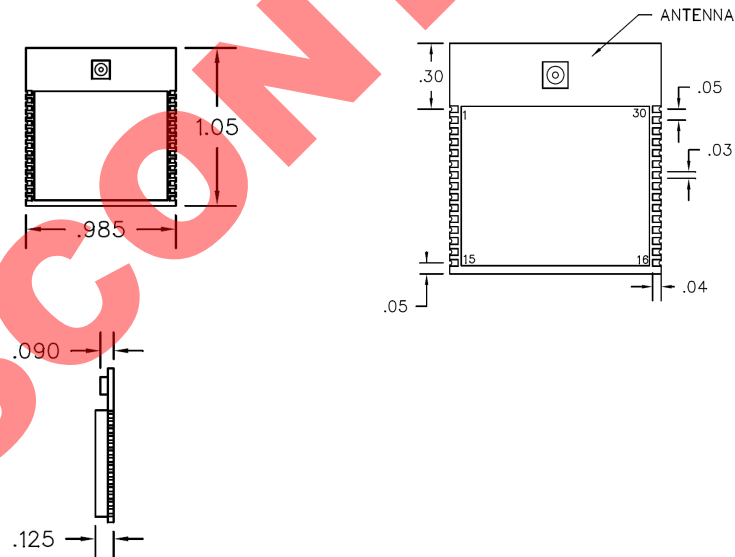

Figure 10

WirelessHART® is a registered trademark of the HART Communication Foundation
SmartMesh IA-510(H)™ is a trademarks of DUST Networks, Inc.

P/N M-2510-0000 Rev A