

**WARNING!**

DO NOT LOOK AT OPERATING LED.  
 This circuit produces light that can damage eyes.

## DESCRIPTION

Demonstration circuit 905 is a LED Driver in SC70 With Built-in Schottky featuring the LT3491. The LT3491 is a fixed frequency step-up current mode DC/DC converter. There are two circuits on demonstration board 905. The “Small Size” circuit generates 15mA LED current at the smallest possible solution size. The “High Efficiency” circuit generates 20mA LED current at higher efficiency. The circuit outputs share 6 LEDs. At any given time, depending on the positions of jumpers, only one circuit is in operation. Other features of the LT3491, such as the internal schottky diode, the high switching frequency and the internal open circuit protection, allow tiny components for both circuits. The input range of the demo board is from 3V to 5V. Different dimming controls can

be implemented on the demo board. Please refer to the quick start procedure. The high side current sensing feature of the LT3491 allows “one wire” current source, i.e. the low side of the LED string can return to ground anywhere.

The LT3491 datasheet gives a complete description of the part, operation and application information. The datasheet must be read in conjunction with this quick start guide for working on or modifying demo circuit 905.

**Design files for this circuit board are available. Call the LTC factory.**

LT, LTC and LT are registered trademarks of Linear Technology Corporation. ThinSOT and PowerPath are trademarks of Linear Technology Corporation.

## PERFORMANCE SUMMARY

Specifications are at  $T_A = 25^\circ\text{C}$

SYMBOL	PARAMETER	CONDITIONS	MIN	TYP	MAX	UNITS
$V_{IN}$	Input Supply Range **		3		5	V
$I_{OUT}$	Output Current	Small Size circuit	14.25	15	15.75	mA
		High Efficiency circuit	19	20	21	
$V_{OUT}$	Output Voltage	Small Size circuit		20.3		V
		High Efficiency circuit		20.6		
$\eta$	Efficiency	$V_{IN} = 4.2\text{V}$ , Small Size circuit		73.6		%
		$V_{IN} = 4.2\text{V}$ , High Efficiency circuit		75.5		
$V_{OPEN}$	CAP pin Over-voltage Protection	LED Open	26	27	28	V
$I_Q$	Quiescent Current	$V_{IN} = 4.2\text{V}$ , CTRL = ON			4	mA
$I_{QSHDN}$	Quiescent Current While in Shutdown	$V_{IN} = 4.2\text{V}$ , CTRL = OFF			10	$\mu\text{A}$
$F_s$	Switching Frequency		1.8	2.3	2.8	MHz

\*\* The Input Supply Range of demo circuit 905 is limited by the input capacitors. The input voltage absolute maximum rating of the LT3491 is 12V.

## QUICK START PROCEDURE

Demonstration circuit 905 is easy to set up to evaluate the performance of the LT3491. Refer to Figure 1 for proper measurement equipment setup and follow the procedure below:

**NOTE .** When measuring the input or output voltage ripple, care must be taken to avoid a long ground lead on the oscilloscope probe. Measure the input or output voltage ripple by touching the probe tip directly across the Vin or Vout and GND terminals. See Figure 2 for proper scope probe technique.

1. Place jumpers in the following positions to test the "SMALL SIZE" circuit:

<b>JP1</b>	ON
<b>JP2</b>	OFF
<b>JP3</b>	SIZE
<b>JP4</b>	SIZE

2. Place jumpers in the following positions to test the "HIGH EFFICIENCY" circuit:

<b>JP1</b>	OFF
<b>JP2</b>	ON
<b>JP3</b>	EFFICIENCY
<b>JP4</b>	EFFICIENCY

3. Prior to connection, preset the input power supply to the desired voltage (3V to 5V). With power off, connect the input power supply to VIN and GND.

4. Turn on the power at the input.

**NOTE .** Make sure that the input voltage does not exceed 5V.

5. Check for the proper voltages and currents.

**NOTE .** If the LEDs do not light up, check all the jumper settings.

6. Once proper operation is established, adjust the input within the operating range and observe the parameters of interest.

7. To test the filtered PWM dimming or the direct DC dimming, remove the jumper JP1 or JP2, apply the PWM or the DC signal to the CTRL1 or CTRL2 and observe the brightness of the LED output.

8. To test the direct PWM dimming, follow the Direct PWM Dimming section in the datasheet.

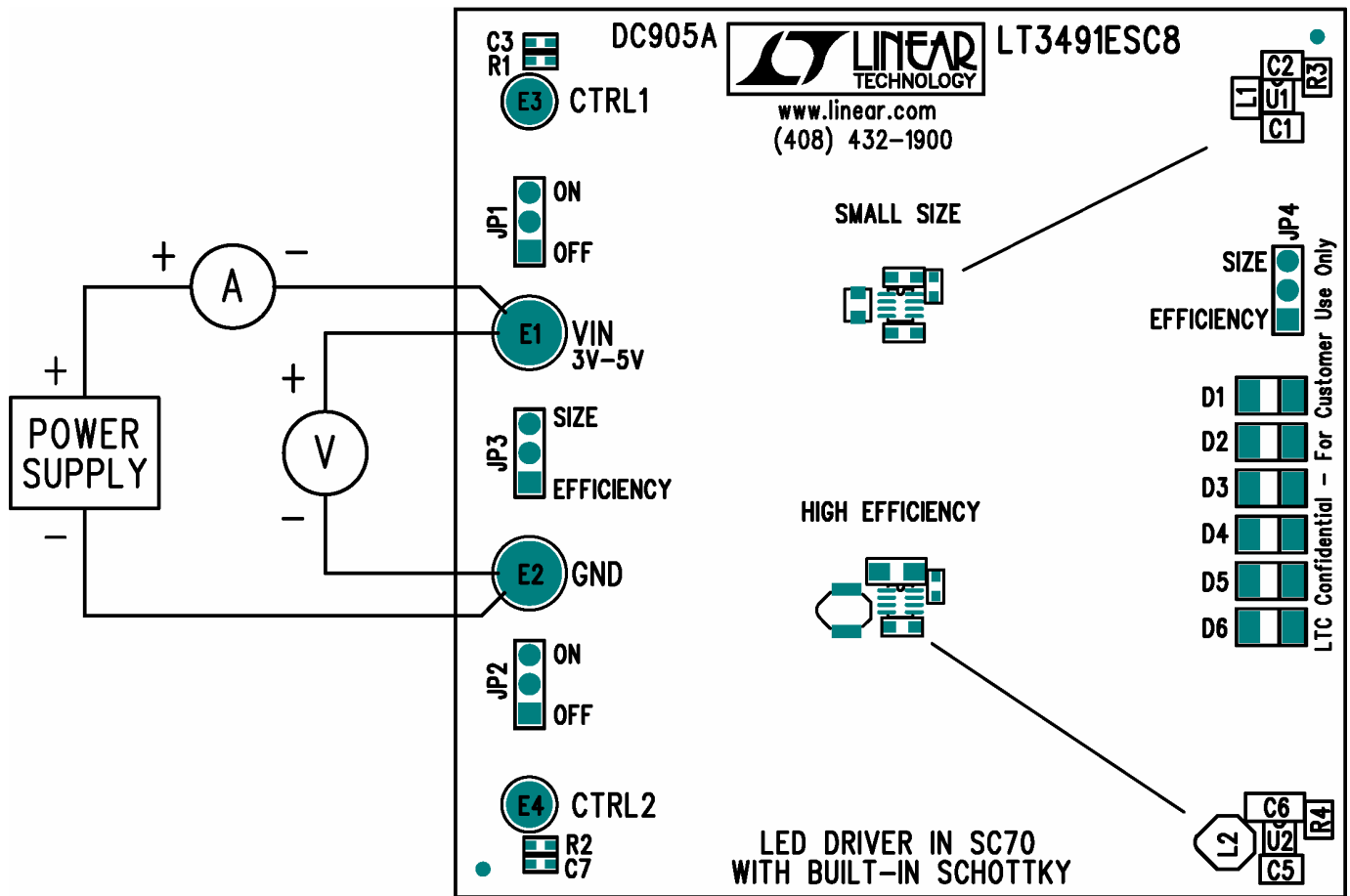

Figure 1. Proper Measurement Equipment Setup

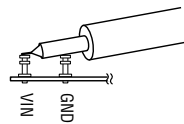
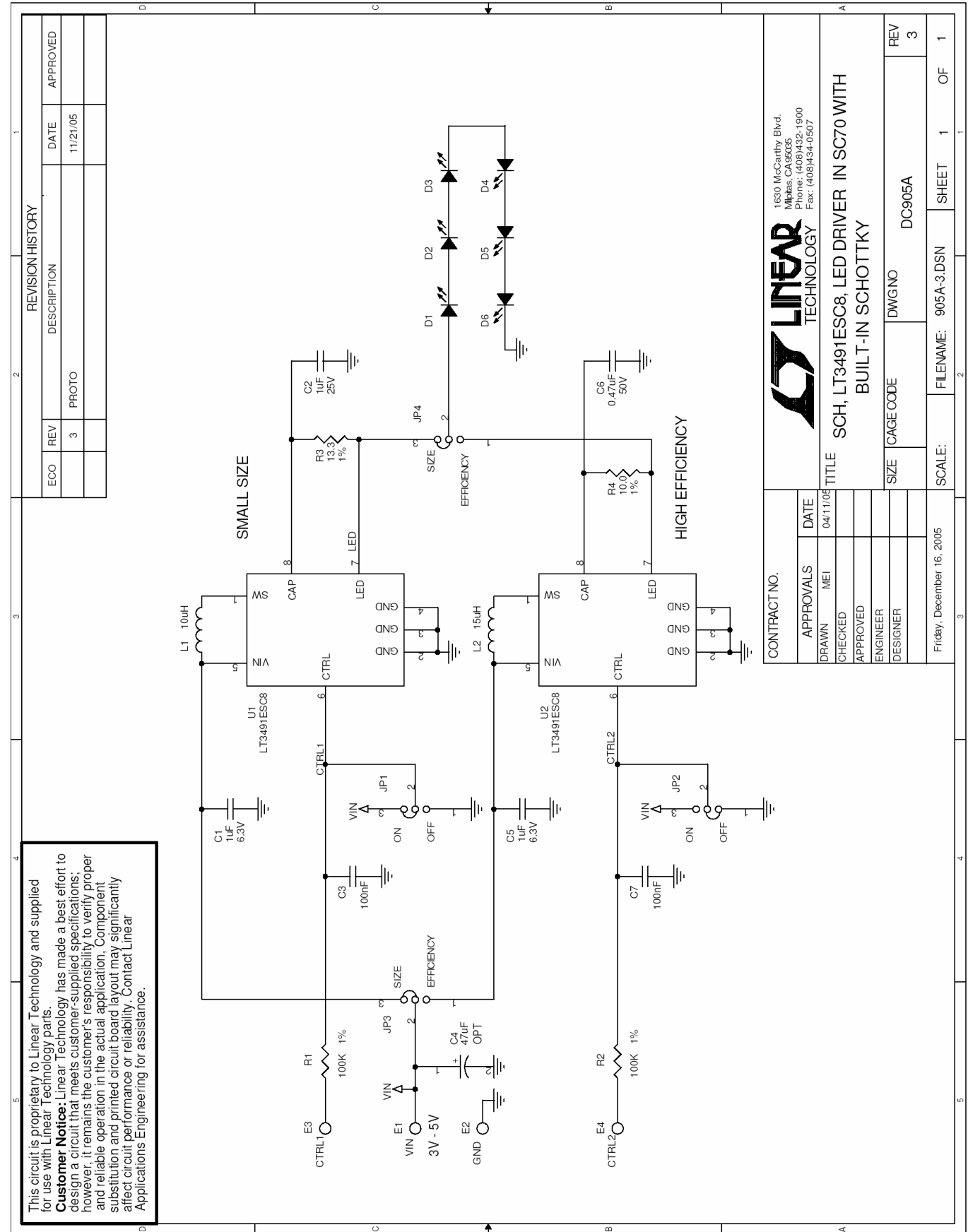

Figure 2. Measuring Input or Output Ripple



This circuit is proprietary to Linear Technology and supplied for use with Linear Technology parts.  
**Customer Notice:** Linear Technology has made a best effort to design a circuit that meets customer-supplied specifications; however, it remains the customer's responsibility to verify proper and reliable operation in the actual application. Component substitution and printed circuit board layout may significantly affect circuit performance or reliability. Contact Linear Applications Engineering for assistance.

REVISION HISTORY				
ECO	REV	DESCRIPTION	DATE	APPROVED
	3	PROTO	11/21/05	

CONTRACT NO.		DATE	
APPROVALS	MEI	04/11/05	
CHECKED			
APPROVED			
ENGINEER			
DESIGNER			

TITLE		SCALE:	
SCH, LT3491ESC8, LED DRIVER IN SC70 WITH BUILT-IN SCHOTTKY		Friday, December 16, 2005	
SIZE	CAGE CODE	FILENAME:	SHEET
DWGNO	DC905A	905A-3.DSN	1 OF 1
REV			
3			



1650 McCarthy Blvd.  
 Milpitas, CA 95035  
 Phone: (408)432-1900  
 Fax: (408)434-0507