

# LT8714

## Synchronous Four-Quadrant Converter

### DESCRIPTION

Demonstration circuit 2240A is a synchronous four-quadrant converter featuring the LT<sup>®</sup>8714 switching controller. The LT8714 can regulate to positive, negative, or zero volts when configured as a four-quadrant topology. The DC2240A regulates from a 10V to 14V input source to an adjustable output voltage from positive 5V to negative 5V with a 5A maximum current rating, and operates at 200kHz switching frequency.

The LT8714 incorporates a power good feature to let the user know if the output voltage is within its target regulation voltage.

The LT8714 has an output voltage control (CTRL) pin which sets the output voltage. The DC2240A has a

jumper to select the CTRL pin voltage source from either externally (EXT) or internally (INT). If selected internally, the output voltage can be set to +5V or -5V. If selected externally, the output voltage can vary between positive 5V and negative 5V, following a 0.1V – 1V CTRL signal with high bandwidth.

The LT8714 data sheet gives a complete description of the part, operation and application information. The data sheet must be read in conjunction with this quick start guide for demo circuit 2240A.

**Design files for this circuit board are available at <http://www.linear.com/8714>**

LT, LT, LTC, LTM, Linear Technology and the Linear logo are registered trademarks of Linear Technology Corporation. All other trademarks are the property of their respective owners.

### PERFORMANCE SUMMARY Specifications are at T<sub>A</sub> = 25°C

PARAMETER	CONDITIONS	MIN	TYP	MAX	UNITS
Input Voltage		10	12	14	V
Positive Output Voltage (Max)	V <sub>IN</sub> = 10V – 14V	4.85	5	5.15	V
Negative Output Voltage (Max)	V <sub>IN</sub> = 10V – 14V	-4.85	-5	-5.15	V
Maximum Output Current		5			A
Positive Output Voltage Ripple	V <sub>IN</sub> = 10V – 14V, V <sub>OUT</sub> = 5V, I <sub>OUT</sub> = 5A (20MHz BW)		25		mV <sub>p-p</sub>
Negative Output Voltage Ripple	V <sub>IN</sub> = 10V – 14V, V <sub>OUT</sub> = -5V, I <sub>OUT</sub> = -5A (20MHz BW)		25		mV <sub>p-p</sub>
Typical Switching Frequency			200		kHz
Efficiency	V <sub>IN</sub> = 12V, V <sub>OUT</sub> = 5V, I <sub>OUT</sub> = 5A		89		%
	V <sub>IN</sub> = 12V, V <sub>OUT</sub> = -5V, I <sub>OUT</sub> = -5A		80		%

Figure 1. DC2240A Connection Diagram

## QUICK START PROCEDURE

Demonstration circuit 2240A is easy to set up to evaluate the performance of the LT8714. Refer to Figure 1 for proper measurement equipment setup and follow the procedure below:

1. With the power off, connect the input power supply to the board through  $V_{IN}$  and PGND terminals. Connect the load to the terminals  $V_{OUT}$  and PGND on the board. Make sure that the input power supply has sufficient current rating at minimum input voltage for the required output load.
2. Turn on the power at the input.

NOTE: Make sure that the input voltage does not exceed 14V.

3. Check for the proper output voltages. The output should be regulated at +5.0V ( $\pm 3\%$ ).

If there is no output, temporarily disconnect the load to make sure that the load is not set too high.

4. Once the proper output voltage is established, adjust the input voltage and load current within the operating range and observe the output voltage regulation, ripple voltage, efficiency and other parameters.

NOTE: When measuring the input or output voltage ripples, care must be taken to avoid a long ground lead on the oscilloscope probe. Measure the input or output voltage ripple by touching the probe tip directly across the  $V_{IN}$  and PGND, or  $V_{OUT}$  and PGND terminals. See Figure 2 for proper scope probe technique.

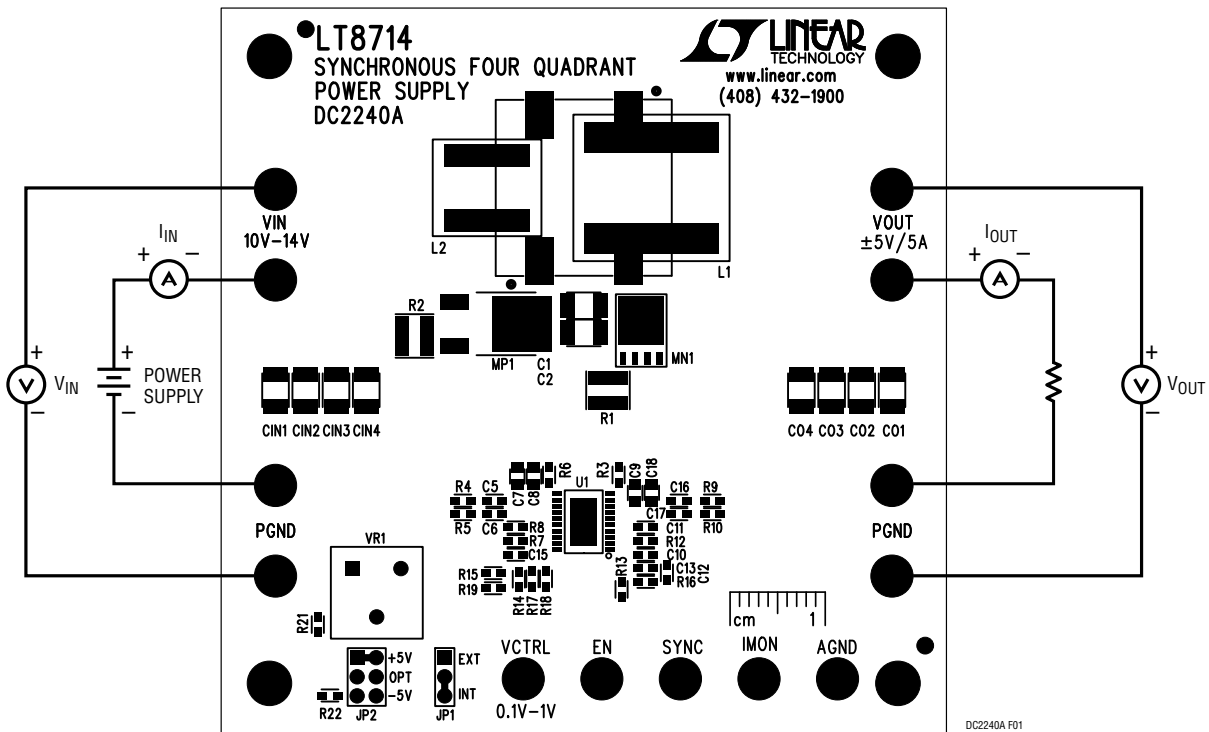
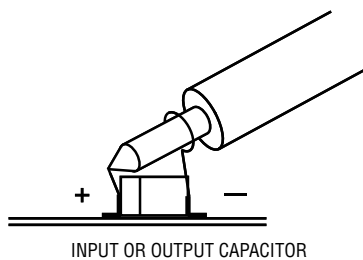
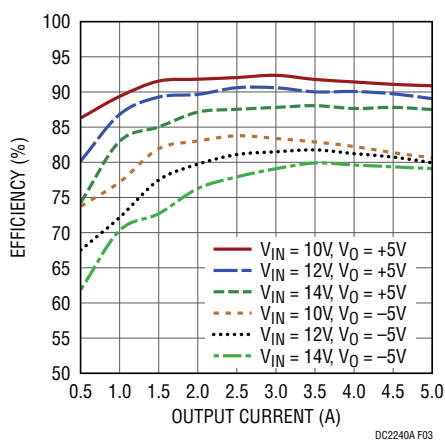

Figure 1. Proper Measurement Equipment Setup

**QUICK START PROCEDURE**



**Figure 2. Proper Scope Probe Placement for Measuring Input or Output Ripple**



**Figure 3. Typical Efficiency Curve**

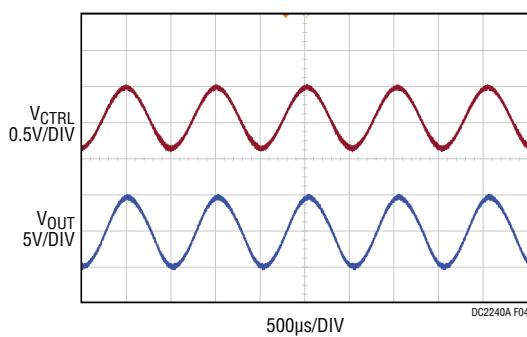

**Figure 4. Output Voltage Varies Between -5V and +5V, Following an Externally Controlled 0.1V to 1V, 1kHz Sinusoidal Voltage Source**

# DEMO MANUAL DC2240A

## PARTS LIST

ITEM	QTY	REFERENCE	PART DESCRIPTION	MANUFACTURER/PART NUMBER
<b>Required Circuit Components</b>				
1	4	CIN1, CIN2, CIN3, CIN4	CAP., X5R, 22 $\mu$ F, 25V, 10%, 1210	MURATA, GRM32ER61E226KE15L
2	6	C1, C2, C3, C4, C20, C21	CAP., X5R, 22 $\mu$ F, 25V, 10%, 1210	MURATA, GRM32ER61E226KE15L
3	2	CO1, CO2	CAP., X5R, 100 $\mu$ F, 10V, 20%, 1210	MURATA, GRM32ER61A107ME20K
4	3	C7, C8, C9	CAP., X7R, 2.2 $\mu$ F, 25V, 10%, 0805	MURATA, GRM21BR71E225KA73L
5	1	C10	CAP., X7R, 0.68 $\mu$ F, 25V, 10%, 0603	TDK, C1608X7R1E684K080AB
6	1	C11	CAP., X7R, 0.068 $\mu$ F, 25V, 10%, 0603	MURATA, GRM188R71E683KA01D
7	1	C12	CAP., X7R, 0.01 $\mu$ F, 25V, 10%, 0603	MURATA, GRM188R71E103KA01D
8	1	C13	CAP., X7R, 100pF, 25V, 10%, 0603	AVX, 06033C101KAT2A
9	1	C15	CAP., X7R, 0.1 $\mu$ F, 16V, 10%, 0603	MURATA, GRM188R71C104KA01D
10	1	L1	INDUCTOR, 15 $\mu$ H	Coilcraft, XAL1510-153
11	1	L2	INDUCTOR, 15 $\mu$ H	Coilcraft, XAL1010-153
12	1	MN1	N-CH FET, PG-TDSON-8	INFINEON, BSC034N06NS
13	1	MP1	P-CH FET, DPAK	FAIRCHILD, FDD4141
14	1	R1	RES., SENSE, 7 m $\Omega$ , 1%, RL3720W	SUSUMU, RL3720WT-R007-F
15	1	R2	RES., SENSE, 2 m $\Omega$ , 1%, RL3720W	SUSUMU, RL3720WT-R002-F
16	6	R3, R4, R5, R6, R9, R10	RES., 0 $\Omega$ , 0.1W, 1%, 0603	VISHAY, CRCW06030000Z0EA
17	1	R7	RES., 10k, 1/10W, 1%, 0603	VISHAY, CRCW060310K0FKEA
18	1	R8	RES., 57.6k, 1/10W, 1%, 0603	VISHAY, CRCW060357K6FKEA
19	1	R16	RES., 6.98k, 1/10W, 1%, 0603	VISHAY, CRCW06036K98FKEA
20	1	R19	RES., 18.7k, 1/10W, 1%, 0603	VISHAY, CRCW060318K7FKEA
21	3	R12, R15, R18	RES., 100k, 1/10W, 1%, 0603	VISHAY, CRCW0603100KfKEA
22	1	R13	RES., 73.2k, 1/10W, 1%, 0603	VISHAY, CRCW060373K2FKEA
23	1	R14	RES., 100, 1/10W, 1%, 0603	VISHAY, CRCW0603100RfKEA
24	1	R17	RES., 178k, 1/10W, 1%, 0603	VISHAY, CRCW0603178KfKEA
25	1	R19	RES., 18.7k, 1/10W, 1%, 0603	VISHAY, CRCW060318K7FKEA
26	1	R20	RES., 1 $\Omega$ , 1/4W, 1%, 1206	VISHAY, CRCW12061R00fKEA
27	1	R22	RES., 1.78k, 1/10W, 1%, 0603	VISHAY, CRCW06031K78FKEA
28	1	U1	I.C., VOLTAGE REGULATOR, 20TSSOP	LINEAR TECHNOLOGY, LT8714EFE#PBF
29	1		FAB, PRINTED CIRCUIT BOARD	DEMO CIRCUIT 2240A
<b>Additional Demo Board Circuit Components</b>				
1	0	CO3, CO4 (OPT)	CAP., OPTION, 1210	
2	0	C5, C6, C16, C17 (OPT)	CAP., OPTION, 0603	
3	0	C18 (OPT)	CAP., OPTION, 0805	
4	0	VR1 (OPT)	TRIMMER, OPT	
5	0	R21 (OPT)	RES., OPT, 0603	
6	0	MN2 (OPT)	N-CH FET, OPTION, DPAK	
7	0	MP2 (OPT)	P-CH FET, OPTION, PG-TDSON-8	
<b>Hardware: For Demo Board Only</b>				
1	13	E1-E13	TESTPOINT, TURRET, .094" PbF	MILL-MAX, 2501-2-00-80-00-00-07-0
2	1	JP1	HEADER 3 PIN 0.079 SINGLE ROW	WURTH ELEKTRONIK, 620 003 111 21
3	1	JP2	HEADER 3 PIN 0.079 DOUBLE ROW	WURTH ELEKTRONIK, 620 006 211 21
4	2	XJP1, XJP2	SHUNT, 0.079" CENTER	WURTH ELEKTRONIK, 608 002 134 21
5	4	MH1-MH4	STAND-OFF, NYLON 0.50"	KEYSTONE, 8833 (SNAP ON)

## SCHEMATIC DIAGRAM

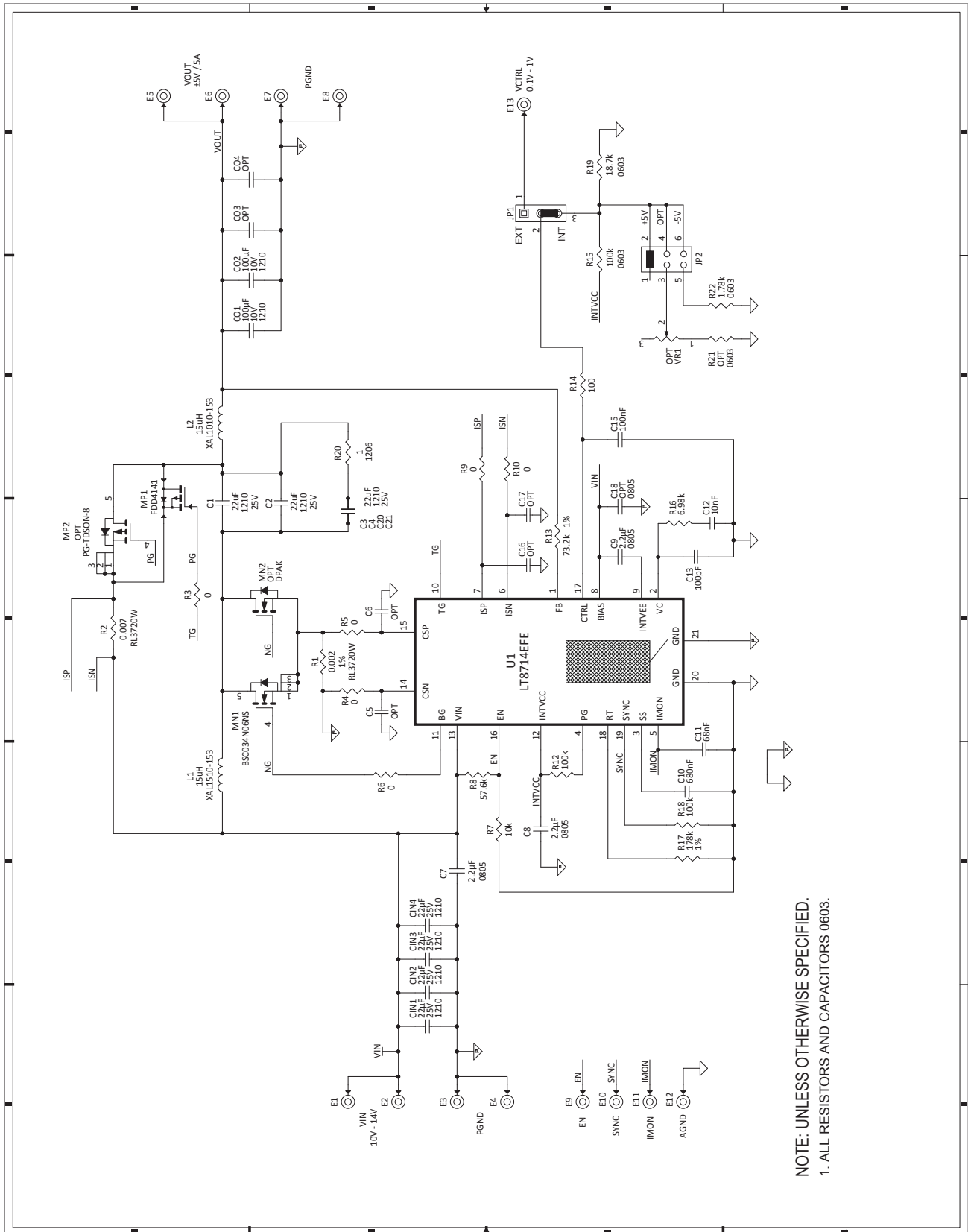

NOTE: UNLESS OTHERWISE SPECIFIED,  
1. ALL RESISTORS AND CAPACITORS 0603.

# DEMO MANUAL DC2240A

---

## DEMONSTRATION BOARD IMPORTANT NOTICE

Linear Technology Corporation (LTC) provides the enclosed product(s) under the following **AS IS** conditions:

This demonstration board (DEMO BOARD) kit being sold or provided by Linear Technology is intended for use for **ENGINEERING DEVELOPMENT OR EVALUATION PURPOSES ONLY** and is not provided by LTC for commercial use. As such, the DEMO BOARD herein may not be complete in terms of required design-, marketing-, and/or manufacturing-related protective considerations, including but not limited to product safety measures typically found in finished commercial goods. As a prototype, this product does not fall within the scope of the European Union directive on electromagnetic compatibility and therefore may or may not meet the technical requirements of the directive, or other regulations.

If this evaluation kit does not meet the specifications recited in the DEMO BOARD manual the kit may be returned within 30 days from the date of delivery for a full refund. **THE FOREGOING WARRANTY IS THE EXCLUSIVE WARRANTY MADE BY THE SELLER TO BUYER AND IS IN LIEU OF ALL OTHER WARRANTIES, EXPRESSED, IMPLIED, OR STATUTORY, INCLUDING ANY WARRANTY OF MERCHANTABILITY OR FITNESS FOR ANY PARTICULAR PURPOSE. EXCEPT TO THE EXTENT OF THIS INDEMNITY, NEITHER PARTY SHALL BE LIABLE TO THE OTHER FOR ANY INDIRECT, SPECIAL, INCIDENTAL, OR CONSEQUENTIAL DAMAGES.**

The user assumes all responsibility and liability for proper and safe handling of the goods. Further, the user releases LTC from all claims arising from the handling or use of the goods. Due to the open construction of the product, it is the user's responsibility to take any and all appropriate precautions with regard to electrostatic discharge. Also be aware that the products herein may not be regulatory compliant or agency certified (FCC, UL, CE, etc.).

No License is granted under any patent right or other intellectual property whatsoever. **LTC assumes no liability for applications assistance, customer product design, software performance, or infringement of patents or any other intellectual property rights of any kind.**

LTC currently services a variety of customers for products around the world, and therefore this transaction **is not exclusive**.

**Please read the DEMO BOARD manual prior to handling the product.** Persons handling this product must have electronics training and observe good laboratory practice standards. **Common sense is encouraged.**

This notice contains important safety information about temperatures and voltages. For further safety concerns, please contact a LTC application engineer.

Mailing Address:

Linear Technology  
1630 McCarthy Blvd.  
Milpitas, CA 95035

Copyright © 2004, Linear Technology Corporation