

DESCRIPTION

DC652 is a 3A high efficiency, high frequency buck converter, incorporating the LTC3412A monolithic synchronous regulator. The DC652 has an input voltage range of 2.25V to 5.5V and an output voltage range from 0.8V to 5V. The operating frequency range of the DC652 is either set with an external resistor or synchronized to an external clock, with a range between 300kHz and 4MHz. These features make the DC652 ideal for use in Li-Ion battery (2.7V to 4.2V) applications, such as PDAs, cell phones, and digital cameras. The DC652 can deliver high(er) power – up to 3A of output current – in a relatively small circuit, because of the high current power switches (70mΩ of on-state resistance) on the LTC3412A. The LTC3412A also incorporates OPTI-LOOP

compensation, so that the DC652 can be optimized to provide fast transient response over a wide range of line and load conditions. Extra features include tracking, for easy power supply sequencing, and Burst-Mode™ capability, for those circuits that operate during intervals of low output power. All these features make the DC652 perfectly suited for high current, high power applications, such as notebook or desktop computers.

Design files for this circuit board are available. Call the LTC factory.

LTC and Burst-Mode are trademarks of Linear Technology Corporation

Table 1.

Performance Summary ($T_A = 25^\circ\text{C}$)

PARAMETER	CONDITION	VALUE
Minimum Input Voltage		2.25V
Maximum Input Voltage		5.5V
Output Voltage V_{OUT}	$V_{IN} = 2.25\text{V to } 5.5\text{V}, I_{OUT} = 0\text{A to } 3\text{A}$	$1.8\text{V} \pm 4\%$
Typical Output Ripple V_{OUT}	$V_{IN} = 5\text{V}, I_{OUT} = 3\text{A}$ (20MHz BW)	20mV _{P-P}
Output Regulation	Line	$\pm 1\%$
	Load	$\pm 1\%$
Nominal Switching Frequency	$R_T = 309\text{k}$	1MHz

QUICK START PROCEDURE

The DC652 demonstration board is easy to set up to evaluate the performance of the LTC3412A. For proper measurement equipment configuration, set up the circuit according to the diagram in Figure 1. Before proceeding to test, insert jumper J2 shunt into

the off (lower) position, connecting the RUN pin to ground (GND), which shuts down the circuit.

NOTE: When measuring the input or output voltage ripple, care must be taken to avoid a long ground lead on the oscilloscope probe. Measure the input or output voltage ripple by touching the probe tip directly

QUICK START GUIDE FOR DEMONSTRATION CIRCUIT 652

HIGH EFFICIENCY, 3A MONOLITHIC SYNCHRONOUS BUCK REGULATOR

across the Vin or Vout and GND terminals. See Figure 2 for proper scope probe technique.

1. Connect the input power supply and the load to the board. Do not hot-plug Vin or increase Vin over the rated maximum supply voltage of 5.5V, or the part may be damaged. Refer to figure 1 for the proper measurement equipment setup.
2. Insert shunts into the Force Continuous position of jumper J1, and into the 1.8V output voltage position.
3. Apply 3.3V at Vin. Measure Vout; it should read 0V. If desired, one can measure the shutdown supply current at this point. The supply current will be approximately 1uA in shutdown.
4. Turn on the circuit by inserting the shunt in jumper J2 into the ON (upper) position. The output voltage should be regulating. Measure Vout - it should measure 1.8V +/- 2% (1.764V to 1.836V).
5. Vary the input voltage from 2.25V to 5.5V and adjust the load current from 0 to 3A. Vout should read between 1.8V +/- 4% (1.728V to 1.872V).

6. Measure the output ripple voltage at any output current level; it should measure less than 20mVAC.
7. Observe the voltage waveform at the switch node. Verify the switching frequency is between 0.88MHz and 1.12MHz ($T = 1.13\mu\text{s}$ and $0.893\mu\text{s}$), and that the switch node waveform is rectangular in shape.

Insert jumper J2 shunt into the OFF position and move the 1.8V Vout shunt into any of the remaining output voltage options: 2.5V or 3.3V. Re-insert jumper J2 shunt into the ON position. Just as in the 1.8Vout test, the output voltage should read Vout +/- 2% tolerance under static line and load conditions, and another +/- 2% tolerance under dynamic line and load conditions (+/- 4% total). The Burst-Mode™ capability of the LTC3412A can also be observed now by changing the J3 jumper shunt from the Force Continuous (upper) position to the Burst-Mode™ (lower) position.

When finished, turn off the circuit (connecting the RUN pin to ground) by inserting the shunt in jumper J2 into the OFF (lower) position.

QUICK START GUIDE FOR DEMONSTRATION CIRCUIT 652 HIGH EFFICIENCY, 3A MONOLITHIC SYNCHRONOUS BUCK REGULATOR

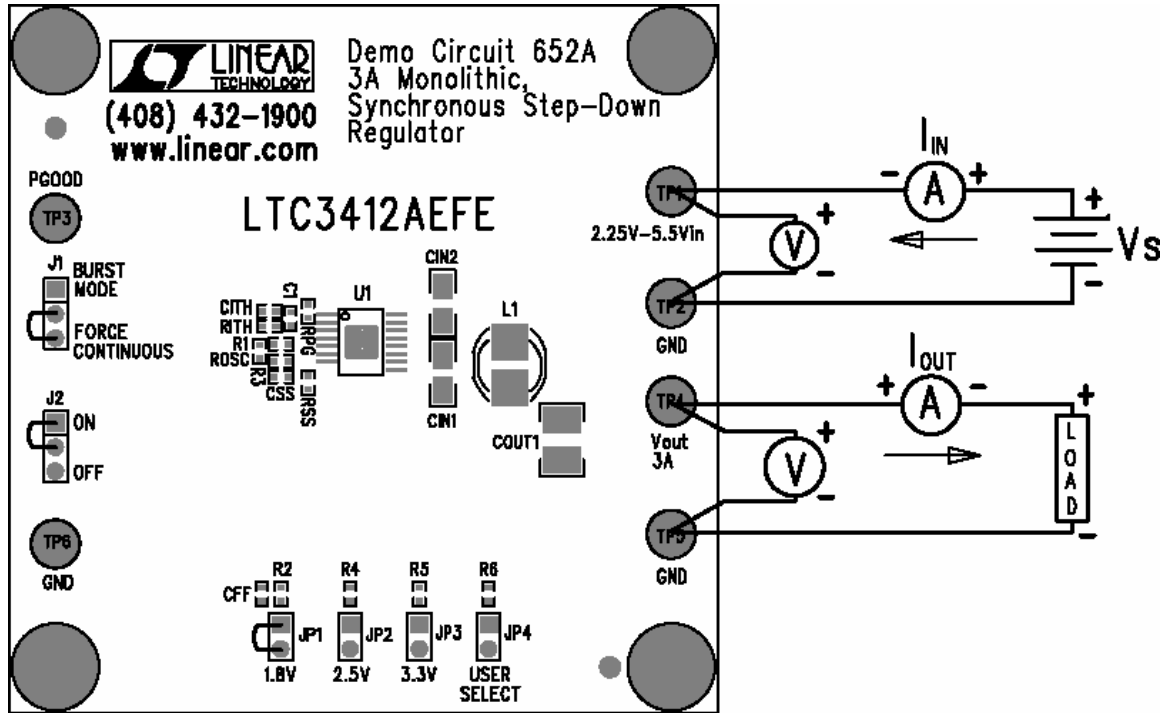

Figure 1. Proper Measurement Equipment Setup

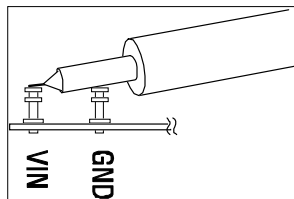

Figure 2. Measuring Input or Output Ripple

QUICK START GUIDE FOR DEMONSTRATION CIRCUIT 652 HIGH EFFICIENCY, 3A MONOLITHIC SYNCHRONOUS BUCK REGULATOR

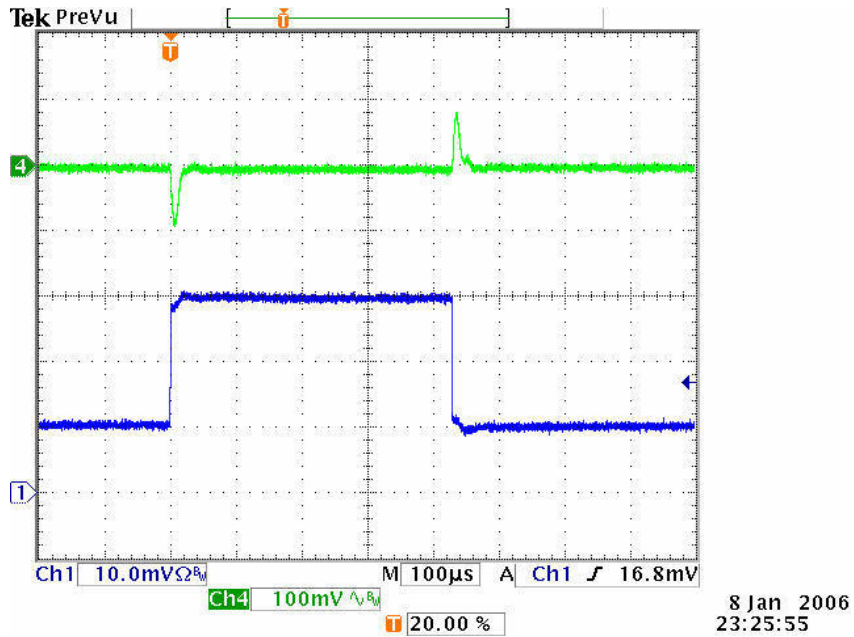
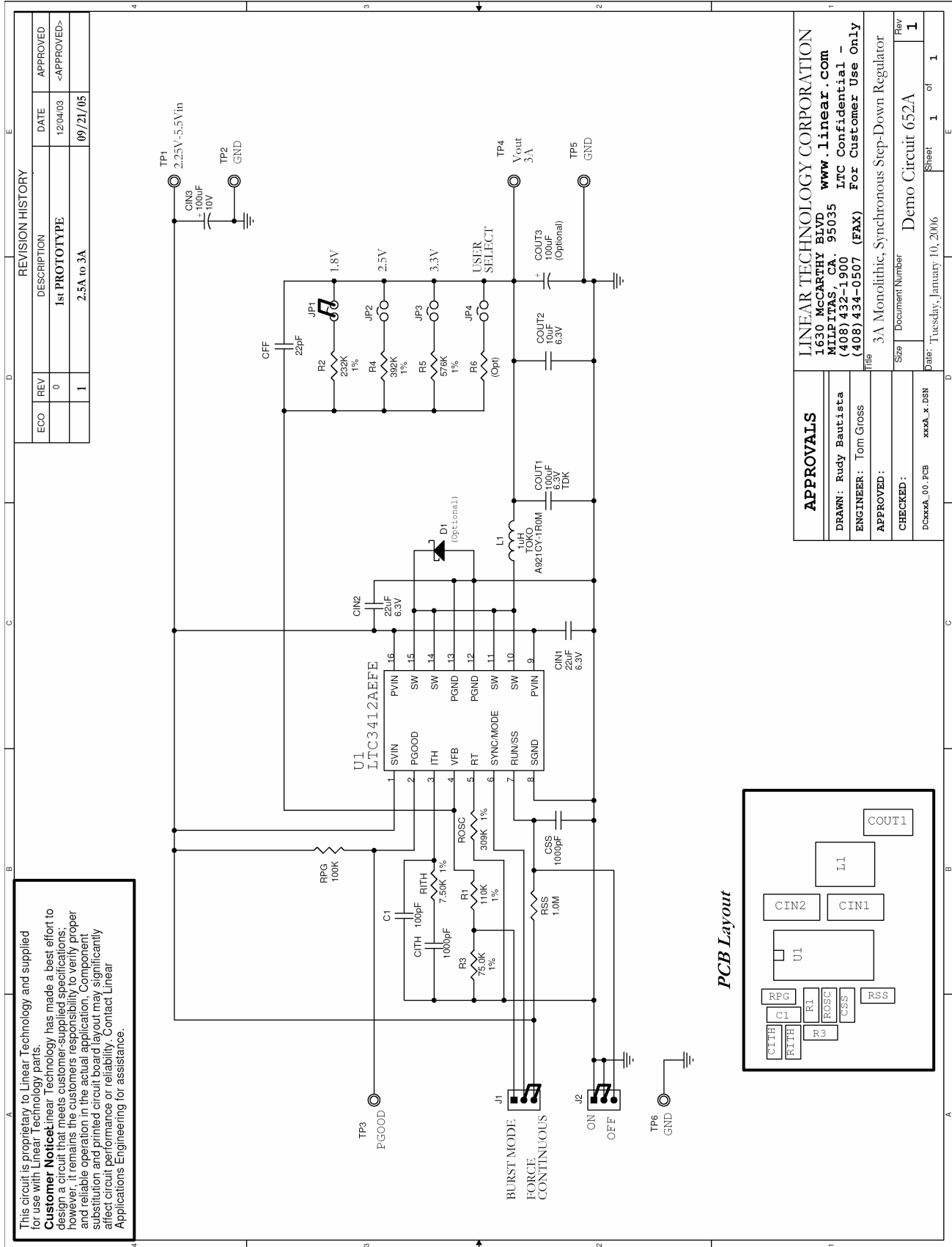

Figure 3. Load Step Response
 $V_{IN} = 3.3V$, $V_{OUT} = 2.5V$, 2A Load Step
Trace 1: Output Voltage (100mV/div AC)
Trace 2: Output Current (1A/div)

QUICK START GUIDE FOR DEMONSTRATION CIRCUIT 652

HIGH EFFICIENCY, 3A MONOLITHIC SYNCHRONOUS BUCK REGULATOR



REVISION HISTORY				
ECO	REV	DESCRIPTION	DATE	APPROVED
	0	1st PROTOTYPE	12/04/03	<APPROVED>
	1	2.5A to 3A	09/21/05	

This circuit is proprietary to Linear Technology and supplied for use with Linear Technology parts.
Customer Notice: Linear Technology has made a best effort to design a circuit that meets customer-supplied specifications; however, it remains the customer's responsibility to verify proper and reliable operation in the actual application. Component substitution and printed circuit board layout may significantly affect circuit performance or reliability. Contact Linear Applications Engineering for assistance.

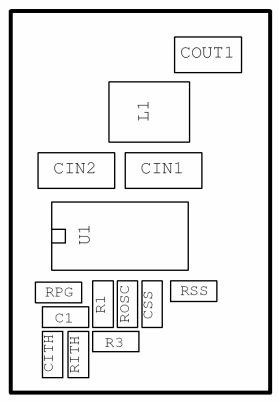

APPROVALS	
DRAWN: Rudy Bautista	www.linear.com
ENGINEER: Tom Gross	MILPITAS, CA. 95035
APPROVED:	LTC Confidential - For Customer Use Only
CHECKED: xxxxx.x.DSV	3A Monolithic, Synchronous Step-Down Regulator
DCxxxx.00.PCB	Document Number
	Demo Circuit 652A
	Rev 1
Date: Tuesday, January 10, 2006	Sheet 1 of 1