

LTC3108EDE/ LTC3108EDE-1 Ultralow Voltage Step-Up Converter and Power Manager

DESCRIPTION

Demonstration Circuit 1582B featuring the LTC3108 is a highly integrated DC/DC converter optimized for harvesting and managing energy from extremely low input voltage sources such as thermoelectric generators (TEG). The step-up topology operates from input voltages as low as 20mV.

The DC 1582B Demonstration Circuit has been optimized for low start-up voltage with a 100:1 turns ratio transformer. For application where it is desirable to trade-off a higher start-up voltage for higher current, a lower turns ratio transformer can be used. Refer to the LTC3108 datasheet for more information.

The LTC3108 is designed to accumulate and manage energy over a long period of time to enable short bursts of power to be used to acquire and transmit data. The burst must occur at a low enough duty cycle such that the total output energy during the burst does not exceed the average source power integrated over the accumulation time between bursts.

The Demonstration Circuit has been set up with a storage capacitor that makes it easy to evaluate the general functionality of the circuit. The lower value capacitor allows for a fast charge time but limits the pulsed energy that can be drawn from it. Space is provided, and alternate part footprints have been built into the PCB to allow experimentation with larger capacitors for more energy storage. In a typical application, the larger output capacitors may be used. Refer to the datasheet for more information including equations to properly size the output capacitors for a given application.

The LTC3108 is available in two versions, the only difference being the VOUT and VOUT2 output voltages. Refer to the datasheets for more information.

Design files for this circuit board are available. Call the LTC factory.

 LTC, LTM, LT, Burst Mode, are registered trademarks of Linear Technology Corporation. All other trademarks are the property of their respective owners.

TABLE 1. Typical Specifications (25°C)

Input Voltage Range	50mV-400mV (Typical no load start-up = 20mV)
VLDO	2.2V
VOUT	Jumper Selectable from 2.35 to 5.0V
VOUT2	Switched Output, VOUT2=VOUT
VSTORE	5.25V

QUICK START PROCEDURE

Using short twisted pair leads for any power connections and with all loads and power supplies off, refer to Figure 1 for the proper measurement and equipment setup. The Power Supply (PS1) should not be connected to the circuit until told to do so in the procedure below.

Two versions of the demo board are available. Assembly build –A uses the LTC3108EDE while Assembly build –B uses the LTC3108EDE-1. The only difference is the VOUT and VOUT2 voltages.

When measuring the input or output voltage ripple, care must be taken to avoid a long ground lead on the oscilloscope probe. Measure the input or output voltage ripple by touching the probe tip directly across the VCC or VOUT and GND terminals. See Figure 2 for proper scope probe technique.

1. Jumper, Power Supply and LOAD Settings to start:
PS1= OFF
LOADS = OFF
JP1 (VOUT2) = ON
JP2= VAUX
JP3 = VAUX
2. Turn on PS1 and slowly increase voltage until the voltage at VIN is 50mV. Monitor input current. If input current exceeds 50 mA turn off PS1 and look for shorts.
3. Confirm VLDO = 2.2V
4. Increase Vin = 100mV
5. Set LOAD on VLDO to 50 μ A. Set LOAD on VOUT = 25 μ A. Set LOAD on VOUT2 = 25 μ A.
6. For the –A version: Verify VLDO = 2.2V, VOUT \approx 5.0V, VOUT2 \approx 5.0V, and VSTORE \approx 5.2V
7. For the –B version: Verify VLDO = 2.2V, VOUT \approx 4.5V, VOUT2 \approx 4.5V, and VSTORE \approx 5.2V

The board is now ready for operation. The voltage on VOUT and VOUT2 can be modified by changing jumpers JP2 and JP3. The jumper combinations are shown on the demo board.

Several variations of this design are possible, including increasing the energy storage by populating C7, or C9. Please refer to the datasheet for design equations.

LTC3108EDE

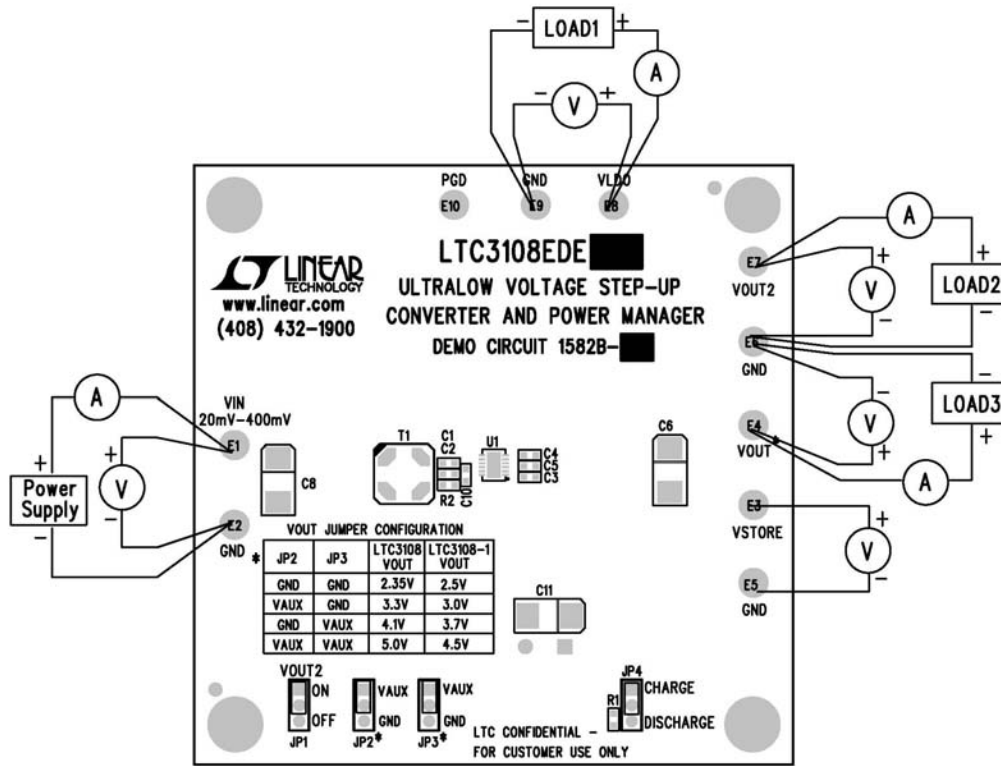

Figure 1. Connection Diagram

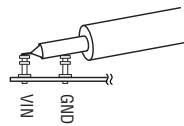

Figure 2. Measuring Input or Output Ripple

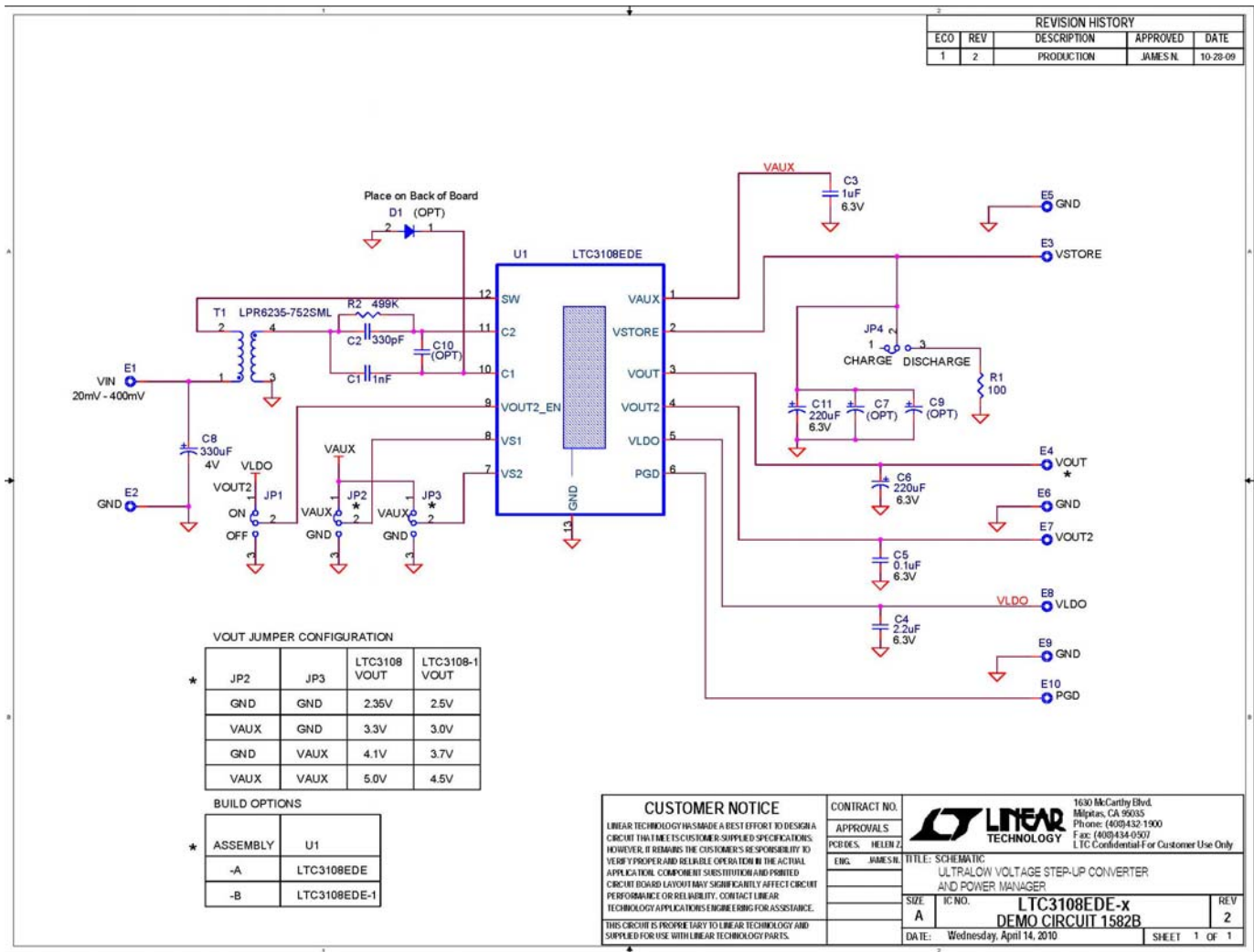

Figure 3. Circuit Schematic

1	1	C8	CAP., POLYMER SMD, 330uF, 4V, 20%	PANASONIC, EEFUE0G331ER
2	1	C1	CAP CER, X7R, 1000pF, 50V, 10%, 0603	PANASONIC, ECJ-1VB1H102K
3	1	C2	CAP CER, X7R, 330pF, 50V, 10%, 0603	PANASONIC, ECJ-1VC1H331J
4	1	C3	CAP CER, X5R, 1uF, 6.3V, 10%, 0603	PANASONIC, ECJ-1VB0J105K
5	1	C4	CAP CER, X5R, 2.2uF, 6.3V, 20%, 0603	PANASONIC, ECJ-1VB0J225K
6	1	C5	CAP CER, X7R, 0.1uF, 16V, 10%, 0603	PANASONIC, ECJ-1VB1C104K
7	2	C6,C11	CAP., POLYMER SMD, 220uF, 6.3V, 20%	PANASONIC, EEFUE0J221ER
8	1	R1	RES., CHIP, 100, 1/10W, 0603	PANASONIC, ERJ-3EKF1000V
9	1	R2	RES., CHIP, 499K, 1/10W, 0603	PANASONIC, ERJ-3EKF4993V
10	1	T1	TRANSFORMERS, 100:1 Turns Ratio	COILCRAFT, LPR6235-752SML
11	1	U1	I.C. LTC3108EDE, DFN 4mm x 3mm	LINEAR TECH., LTC3108EDE#PBF/-1
			Optional Components for Demo Board	
12	0	C7 (OPT)	CAP., 0.47F, 5.5V	COOPER/BUSSMAN, KR-5R5C474-R
13	0	C9 (OPT)	CAP., TANT, 2200uF, 6.3V	VISHAY, 592D228X06R3X2T22H
14	0	C10 (OPT)	OPT, 0603	
15	0	D1(OPT)	DIODE, SWITCHING DIODE, SOD-123	DIODES INC, 1N4148W-7
			Hardware for Demo Board Only	
16	10	E1-E10	TESTPOINT, TURRET, .095"	MILL-MAX, 2501-2-00-80-00-00-07-0
17	4	JP1-JP4	3 PIN 0.079 SINGLE ROW HEADER	SAMTEC, TMM-103-02-L-S
18	4	JP1-JP4	SHUNT,	SAMTEC, 2SN-BK-G
19	4	STAND OFF	STAND-OFF, NYLON 0.50" tall	KEYSTONE, 8833 (SNAP ON)

Figure 4. Bill of Materials