

SMT Power Inductors

Special Features

- Very high current capacity
- High reliability
- Low DCR
- Ferrite bobbin core
- Compact size
- High heat resistance, ideal for reflow soldering
- Test frequency 100KHz
- Operating temperature -55 to +105°C
- Tape & reel packaged 250/reel

Notes

- * Saturation DC current to cause 10% max. inductance drop
- ** Rms current to cause 40°C max. temperature rise
- *** Crosses to the following Bourns Series
@ www.Bourns.com
PM5022 link to Bourns [SDR1806](#)

PM5022 Series				
Part Number	L (uH) ±20%	DCR	I, sat.* (A)	I, rms** (A)
		(Ω) Max.		
PM5022-1R0M	1.0	0.011	20	8.6
PM5022-2R2M	2.2	0.014	16	7.1
PM5022-3R3M	3.3	0.016	14	6.2
PM5022-5R6M	5.6	0.022	12	5.3
PM5022-100M	10	0.032	10	4.3
PM5022-150M	15	0.036	8	4.0
PM5022-220M	22	0.047	7	3.5
PM5022-330M	33	0.066	5.5	3.0
PM5022-470M	47	0.087	4.5	2.6
PM5022-680M	68	0.13	3.5	2.3
PM5022-101M	100	0.19	3.0	1.8
PM5022-151M	150	0.25	2.6	1.5
PM5022-221M	220	0.38	2.4	1.2
PM5022-331M	330	0.56	1.9	1.0
PM5022-471M	470	0.85	1.4	0.82
PM5022-681M	680	1.2	1.2	0.72
PM5022-102M	1000	1.8	1.0	0.56

Also available as RoHS compliant.

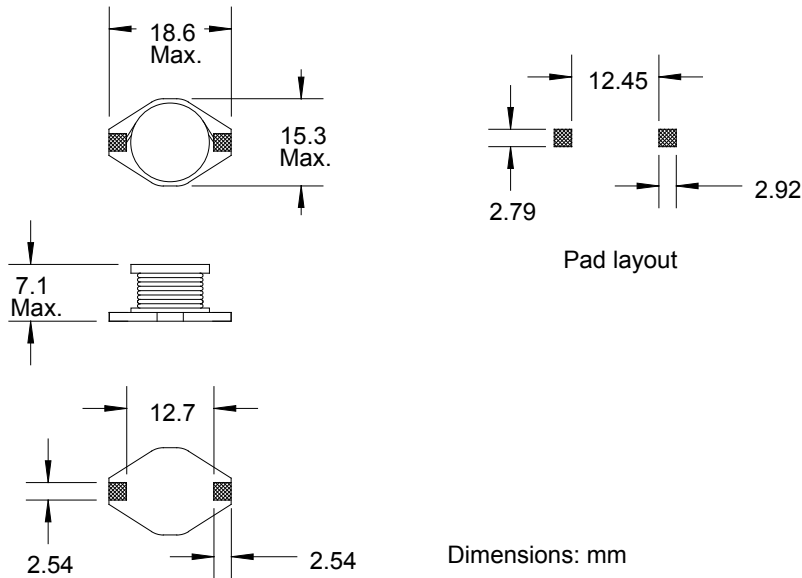

J.W. Miller
MAGNETICS

306 E. Alondra Blvd. Gardena, CA 90247-1059 • Phone (310) 515-1720 • FAX (310) 515-1962

www.jwmiller.com