

FEATURES

- Laser Trimmed to High Accuracy:**
10.000 V \pm 5 mV (L and U Grades)
- Trimmed Temperature Coefficient:**
5 ppm/ $^{\circ}$ C max, (L and U Grades)
- Noise Reduction Capability**
- Low Quiescent Current: 4 mA max**
- Output Trim Capability**
- MIL-STD-883 Compliant Versions Available**

PRODUCT DESCRIPTION

The AD587 represents a major advance in the state-of-the-art in monolithic voltage references. Using a proprietary ion-implanted buried Zener diode and laser wafer trimming of high stability thin-film resistors, the AD587 provides outstanding performance at low cost.

The AD587 offers much higher performance than most other 10 V references. Because the AD587 uses an industry standard pinout, many systems can be upgraded instantly with the AD587. The buried Zener approach to reference design provides lower noise and drift than bandgap voltage references. The AD587 offers a noise reduction pin which can be used to further reduce the noise level generated by the buried Zener.

The AD587 is recommended for use as a reference for 8-, 10-, 12-, 14- or 16-bit D/A converters which require an external precision reference. The device is also ideal for successive approximation or integrating A/D converters with up to 14 bits of accuracy and, in general, can offer better performance than the standard on-chip references.

The AD587J, K and L are specified for operation from 0° C to $+70^{\circ}$ C, and the AD587S, T and U are specified for -55° C to $+125^{\circ}$ C operation. All grades are available in 8-pin cerdip. The J and K versions are also available in an 8-pin Small Outline IC (SOIC) package for surface mount applications, while the J, K, and L grades also come in an 8-pin plastic package.

REV. D

Information furnished by Analog Devices is believed to be accurate and reliable. However, no responsibility is assumed by Analog Devices for its use, nor for any infringements of patents or other rights of third parties which may result from its use. No license is granted by implication or otherwise under any patent or patent rights of Analog Devices.

FUNCTIONAL BLOCK DIAGRAM

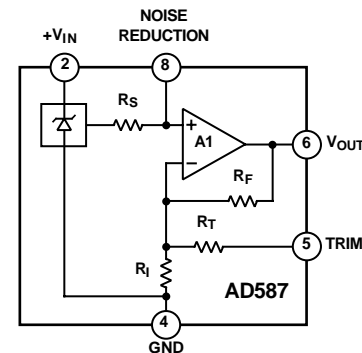

NOTE:
PINS 1,3, AND 7 ARE INTERNAL TEST POINTS.
NO CONNECTIONS TO THESE POINTS.

PRODUCT HIGHLIGHTS

1. Laser trimming of both initial accuracy and temperature coefficients results in very low errors over temperature without the use of external components. The AD587L has a maximum deviation from 10.000 V of \pm 8.5 mV between 0° C and $+70^{\circ}$ C, and the AD587U guarantees \pm 14 mV maximum total error between -55° C and $+125^{\circ}$ C.
2. For applications requiring higher precision, an optional fine trim connection is provided.
3. Any system using an industry standard pinout 10 volt reference can be upgraded instantly with the AD587.
4. Output noise of the AD587 is very low, typically 4 μ V p-p. A noise reduction pin is provided for additional noise filtering using an external capacitor.
5. The AD587 is available in versions compliant with MIL-STD-883. Refer to the Analog Devices Military Products Databook or current AD587/883B data sheet for detailed specifications.

AD587—SPECIFICATIONS ($T_A = +25^\circ\text{C}$, $V_{IN} = +15\text{ V}$ unless otherwise noted)

Model	AD587J/S			AD587K/T			AD587L/U			Units
	Min	Typ	Max	Min	Typ	Max	Min	Typ	Max	
OUTPUT VOLTAGE	9.990		10.010	9.995		10.005	9.995		10.005	V
OUTPUT VOLTAGE DRIFT ¹ 0°C to +70°C -55°C to +125°C			20 20			10 10			5 5	ppm/°C
GAIN ADJUSTMENT	+3 -1			+3 -1			+3 -1			%
LINE REGULATION ¹ 13.5 V ≤ V _{IN} ≤ 36 V T _{MIN} to T _{MAX}			100			100			100	±μV/V
LOAD REGULATION ¹ Sourcing 0 < I _{OUT} < 10 mA T _{MIN} to T _{MAX} Sourcing -10 < I _{OUT} < 0 mA ² T _{MIN} to T _{MAX}			100			100			100	±μV/mA
QUIESCENT CURRENT		2	4		2	4		2	4	mA
POWER DISSIPATION		30			30			30		mW
OUTPUT NOISE 0.1 Hz to 10 Hz Spectral Density, 100 Hz		4 100			4 100			4 100		μV p-p nV/√Hz
LONG-TERM STABILITY		15			15			15		±ppm/1000 Hr.
SHORT-CIRCUIT CURRENT-TO-GROUND		30	70		30	70		30	70	mA
SHORT-CIRCUIT CURRENT-TO-V _{IN}		30	70		30	70		30	70	mA
TEMPERATURE RANGE Specified Performance (J, K, L) Operating Performance (J, K, L) ³ Specified Performance (S, T, U) Operating Performance (S, T, U) ³	0 -40 -55 -55		+70 +85 +125 +125	0 -40 -55 -55		+70 +85 +125 +125	0 -40 -55 -55		+70 +85 +125 +125	°C

NOTES

¹Spec is guaranteed for all packages and grades. Cerdip packaged parts are 100% production test.

²Load Regulation (Sinking) specification for SOIC (R) package is ±200 μV/mA.

³The operating temperature ranged is defined as the temperatures extremes at which the device will still function. Parts may deviate from their specified performance outside their specified temperature range.

Specifications subject to change without notice.

ORDERING GUIDE

Model ¹	Initial Error	Temperature Coefficient	Temperature Range	Package Options ²
AD587JQ	10 mV	20 ppm/°C	0°C to +70°C	Q-8
AD587JR	10 mV	20 ppm/°C	0°C to +70°C	SO-8
AD587JN	10 mV	20 ppm/°C	0°C to +70°C	N-8
AD587KQ	5 mV	10 ppm/°C	0°C to +70°C	Q-8
AD587KR	5 mV	10 ppm/°C	0°C to +70°C	SO-8
AD587KN	5 mV	10 ppm/°C	0°C to +70°C	N-8
AD587LQ	5 mV	5 ppm/°C	0°C to +70°C	Q-8
AD587LN	5 mV	5 ppm/°C	0°C to +70°C	N-8
AD587SQ	10 mV	20 ppm/°C	-55°C to +125°C	Q-8
AD587TQ	10 mV	10 ppm/°C	-55°C to +125°C	Q-8
AD587UQ	5 mV	5 ppm/°C	-55°C to +125°C	Q-8
AD587JCHIPS	10 mV	20 ppm/°C	0°C to +70°C	

NOTES

¹For details on grade and package offerings screened in accordance with MIL-STD-883, refer to the Analog Devices Military Products Databook or current AD587/883B data sheet.

²N = Plastic DIP; Q = Cerdip; SO = SOIC.

ABSOLUTE MAXIMUM RATINGS*

V_{IN} to Ground 36 V
 Power Dissipation (+25°C) 500 mW
 Storage Temperature -65°C to +150°C
 Lead Temperature (Soldering, 10 sec) +300°C
 Package Thermal Resistance
 θ_{JC} 22°C/W
 θ_{JA} 110°C/W
 Output Protection: Output safe for indefinite short to ground and momentary short to V_{IN} .

*Stresses above those listed under Absolute Maximum Ratings may cause permanent damage to the device. This is a stress rating only; functional operation of the device at these or any other conditions above those indicated in the operational sections of this specification is not implied. Exposure to absolute maximum rating conditions for extended periods may affect device reliability.

PIN CONFIGURATION

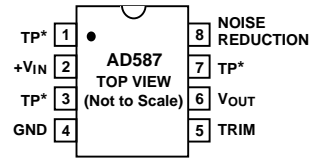

*TP DENOTES FACTORY TEST POINT. NO CONNECTIONS SHOULD BE MADE TO THESE PINS.

DIE SPECIFICATIONS (The following specifications are tested at the die level for AD587JCHIPS. These die are probed at +25°C only. $T_A = +25^\circ\text{C}$, $V_{IN} = +15\text{ V}$ unless otherwise noted)

Parameter	AD587JCHIPS			Units
	Min	Typ	Max	
Output Voltage	9.990	10.010		V
Gain Adjustment	-1	3		%
Line Regulation 13.5 V < V_{IN} < 36 V		100		$\pm\mu\text{V/V}$
Load Regulation Sourcing $0 < I_{OUT} < 10\text{ mA}$ Sinking $-10 < I_{OUT} < 0\text{ mA}$		100		$\mu\text{V/mA}$ $\mu\text{V/mA}$
Quiescent Current	2	4		mA
Short-Circuit Current-to-Ground		70		mA
Short-Circuit Current-to- V_{OUT}		70		mA

DIE LAYOUT

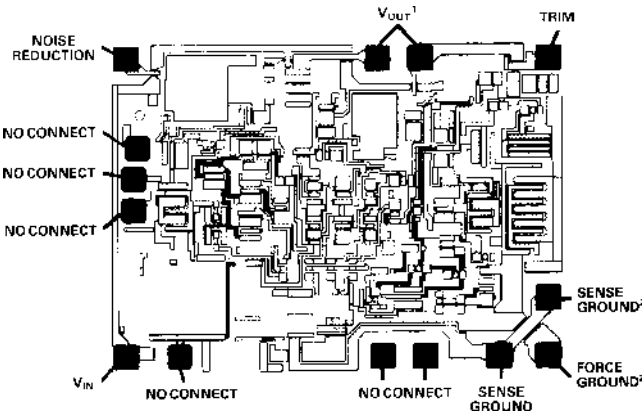

Die Size: 0.081 x 0.060 Inches

NOTES

- ¹Both V_{OUT} pads should be connected to the output.
- ²Sense and force grounds must be tied together.
- Die Thickness:** The standard thickness of Analog Devices Bipolar dice is 24 mils \pm 2 mils.
- Die Dimensions:** The dimensions given have a tolerance of \pm 2 mils.
- Backing:** The standard backside surface is silicon (not plated). Analog Devices does not recommend gold-backed dice for most applications.
- Edges:** A diamond saw is used to separate wafers into dice thus providing perpendicular edges half-way through the die.
In contrast to scribed dice, this technique provides a more uniform die shape and size. The perpendicular edges facilitate handling (such as tweezer pick-up) while the uniform shape and size simplifies substrate design and die attach.
- Top Surface:** The standard top surface of the die is covered by a layer of glassivation. All areas are covered except bonding pads and scribe lines.
- Surface Metalization:** The metalization to Analog Devices bipolar dice is aluminum. Minimum thickness is 10,000Å.
- Bonding Pads:** All bonding pads have a minimum size of 4 mils by 4 mils. The passivation windows have 3.5 mils by 3.5 mils minimum.

AD587

THEORY OF OPERATION

The AD587 consists of a proprietary buried Zener diode reference, an amplifier to buffer the output and several high stability thin-film resistors as shown in the block diagram in Figure 1. This design results in a high precision monolithic 10 V output reference with initial offset of 5 mV or less. The temperature compensation circuitry provides the device with a temperature coefficient of under 5 ppm/°C.

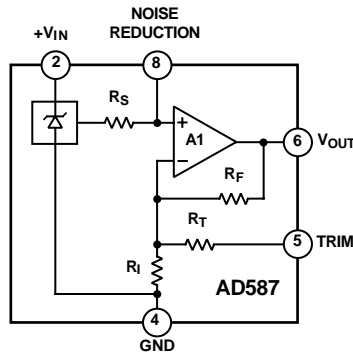

NOTE:
PINS 1,3, AND 7 ARE INTERNAL TEST POINTS.
NO CONNECTIONS TO THESE POINTS.

Figure 1. AD587 Functional Block Diagram

A capacitor can be added at the NOISE REDUCTION pin (Pin 8) to form a low-pass filter with R_S to reduce the noise contribution of the Zener to the circuit.

APPLYING THE AD587

The AD587 is simple to use in virtually all precision reference applications. When power is applied to Pin 2, and Pin 4 is grounded, Pin 6 provides a 10 V output. No external components are required; the degree of desired absolute accuracy is achieved simply by selecting the required device grade. The AD587 requires less than 4 mA quiescent current from an operating supply of +15 V.

Fine trimming may be desired to set the output level to exactly 10.000 V (calibrated to a main system reference). System calibration may also require a reference voltage that is slightly different from 10.000 V, for example, 10.24 V for binary applications. In either case, the optional trim circuit shown in Figure 2 can offset the output by as much as 300 mV, if desired, with minimal effect on other device characteristics.

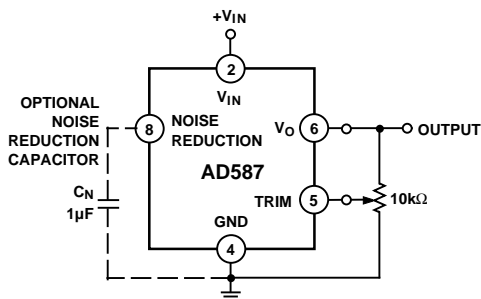

Figure 2. Optional Fine Trim Configuration

NOISE PERFORMANCE AND REDUCTION

The noise generated by the AD587 is typically less than 4 μV p-p over the 0.1 Hz to 10 Hz band. Noise in a 1 MHz bandwidth is approximately 200 μV p-p. The dominant source of this noise is the buried Zener which contributes approximately 100 $\text{nV}/\sqrt{\text{Hz}}$. In comparison, the op amp's contribution is negligible. Figure 3 shows the 0.1 Hz to 10 Hz noise of a typical AD587. The noise measurement is made with a bandpass filter made of a 1-pole high-pass filter with a corner frequency at 0.1 Hz and a 2-pole low-pass filter with a corner frequency at 12.6 Hz to create a filter with a 9.922 Hz bandwidth.

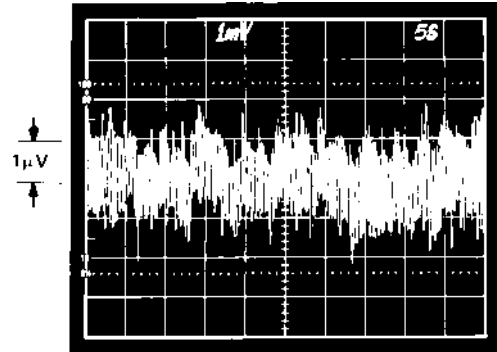

Figure 3. 0.1 Hz to 10 Hz Noise

If further noise reduction is desired, an external capacitor may be added between the NOISE REDUCTION pin and ground as shown in Figure 2. This capacitor, combined with the 4 k Ω R_S and the Zener resistances, form a low-pass filter on the output of the Zener cell. A 1 μF capacitor will have a 3 dB point at 40 Hz, and it will reduce the high frequency (to 1 MHz) noise to about 160 μV p-p. Figure 4 shows the 1 MHz noise of a typical AD587 both with and without a 1 μF capacitor.

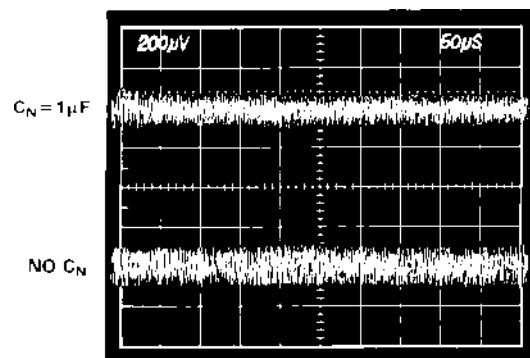
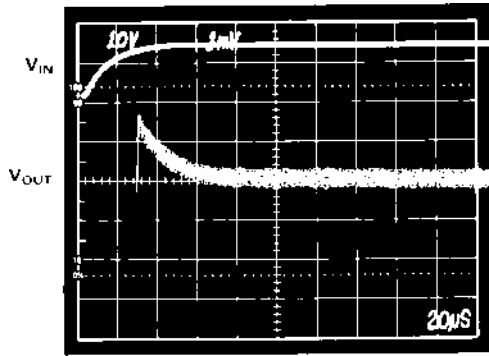

Figure 4. Effect of 1 μF Noise Reduction Capacitor on Broadband Noise

TURN-ON TIME

Upon application of power (cold start), the time required for the output voltage to reach its final value within a specified error band is defined as the turn-on settling time. Two components normally associated with this are: the time for the active circuits to settle, and the time for the thermal gradients on the chip to stabilize. Figure 5 shows the turn-on characteristics of the AD587. It shows the settling to be about 60 μs to 0.01%. Note the absence of any thermal tails when the horizontal scale is expanded to 1 ms/cm in Figure 5b.

Output turn-on time is modified when an external noise reduction capacitor is used. When present, this capacitor acts as an additional load to the internal Zener diode's current source, resulting in a somewhat longer turn-on time. In the case of a 1 μF capacitor, the initial turn-on time is approximately 400 ms to 0.01% (see Figure 5c).



a. Electrical Turn-On

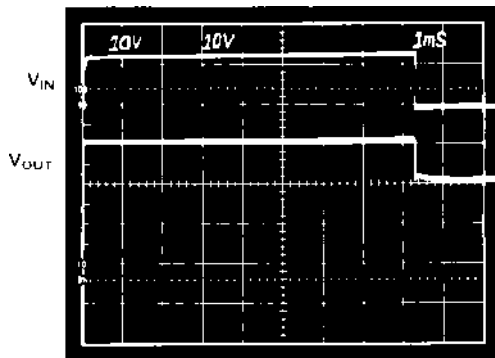

b. Extended Time Scale

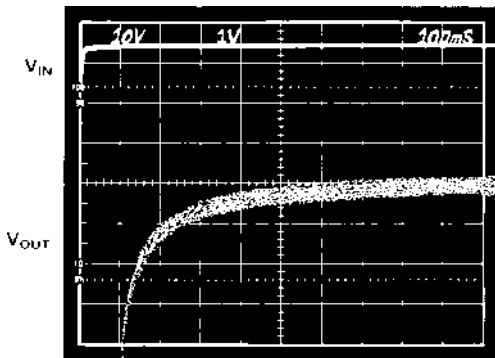

c. Turn-On with 1 μF C_N
Figure 5. Turn-On Characteristics

DYNAMIC PERFORMANCE

The output buffer amplifier is designed to provide the AD587 with static and dynamic load regulation superior to less complete references.

Many A/D and D/A converters present transient current loads to the reference, and poor reference response can degrade the converter's performance.

Figure 6 displays the characteristics of the AD587 output amplifier driving a 0 mA to 10 mA load.

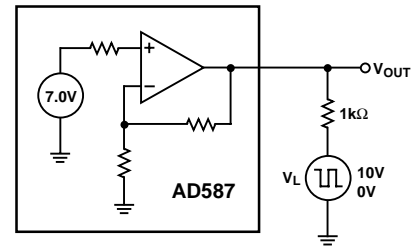

Figure 6a. Transient Load Test Circuit

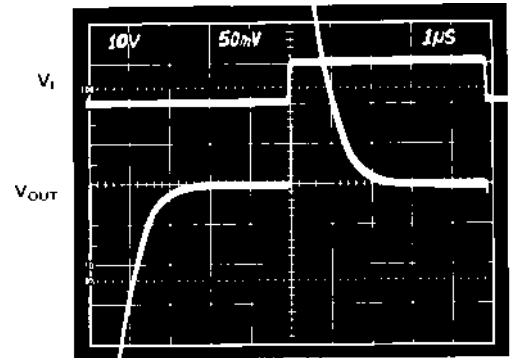

Figure 6b. Large-Scale Transient Response

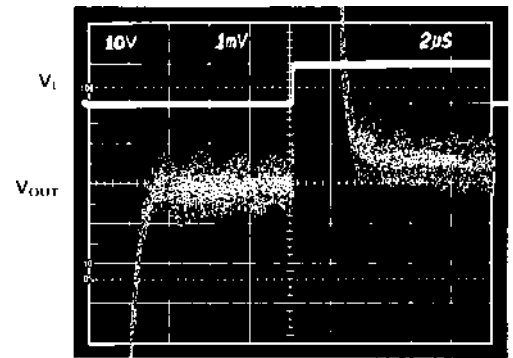

Figure 6c. Fine Scale Settling for Transient Load

AD587

In some applications, a varying load may be both resistive and capacitive in nature, or the load may be connected to the AD587 by a long capacitive cable.

Figure 7 displays the output amplifier characteristics driving a 1000 pF, 0 mA to 10 mA load.

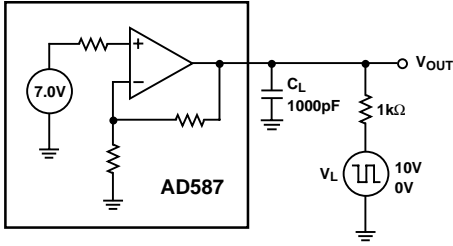

Figure 7a. Capacitive Load Transient/Response Test Circuit

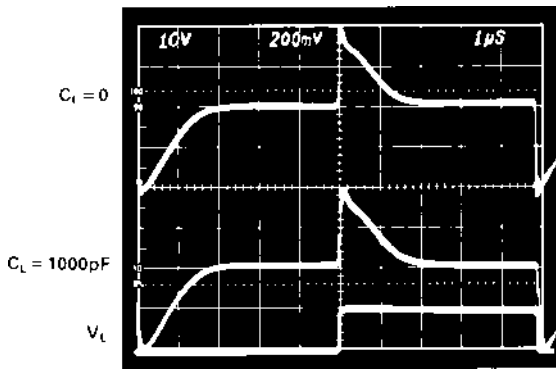

Figure 7b. Output Response with Capacitive Load

LOAD REGULATION

The AD587 has excellent load regulation characteristics. Figure 8 shows that varying the load several mA changes the output by only a few μV.

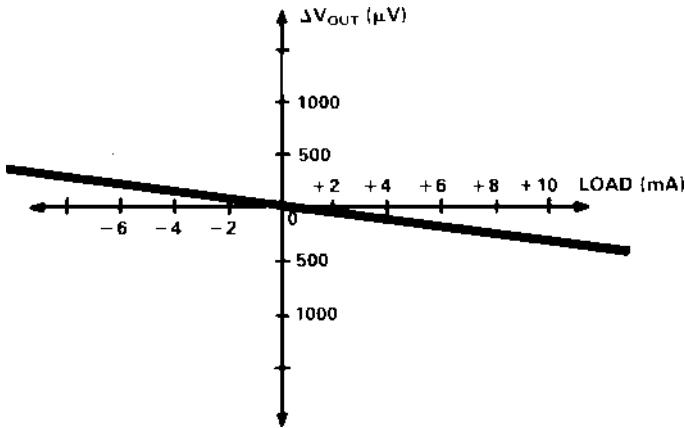

Figure 8. Typical Load Regulation Characteristics

TEMPERATURE PERFORMANCE

The AD587 is designed for precision reference applications where temperature performance is critical. Extensive temperature testing ensures that the device's high level of performance is maintained over the operating temperature range.

Some confusion exists in the area of defining and specifying reference voltage error over temperature. Historically, references have been characterized using a maximum deviation per degree Centigrade; i.e., ppm/°C. However, because of nonlinearities in temperature characteristics which originated in standard Zener references (such as "S" type characteristics), most manufacturers have begun to use a maximum limit error band approach to specify devices. This technique involves the measurement of the output at three or more different temperatures to specify an output voltage error band.

Figure 9 shows the typical output voltage drift for the AD587L and illustrates the test methodology. The box in Figure 9 is bounded on the sides by the operating temperature extremes, and on the top and the bottom by the maximum and minimum output voltages measured over the operating temperature range. The slope of the diagonal drawn from the lower left to the upper right corner of the box determines the performance grade of the device.

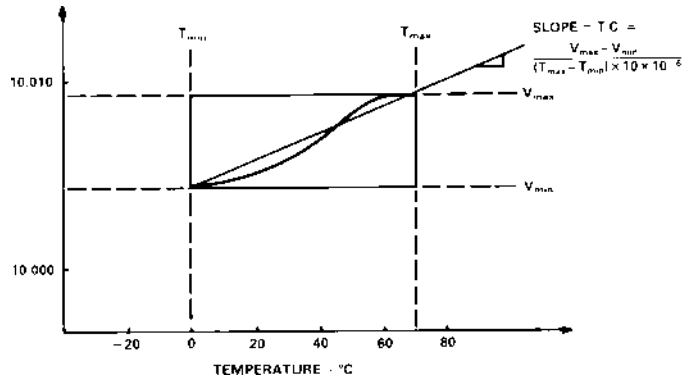

Figure 9. Typical AD587L Temperature Drift

Each AD587J, K, L grade unit is tested at 0°C, +25°C and +70°C. Each AD587S, T, and U grade unit is tested at -55°C, +25°C and +125°C. This approach ensures that the variations of output voltage that occur as the temperature changes within the specified range will be contained within a box whose diagonal has a slope equal to the maximum specified drift. The position of the box on the vertical scale will change from device to device as initial error and the shape of the curve vary. The maximum height of the box for the appropriate temperature range and device grade is shown in Figure 10. Duplication of these results requires a combination of high accuracy and stable temperature control in a test system. Evaluation of the AD587 will produce a curve similar to that in Figure 9, but output readings may vary depending on the test methods and equipment utilized.

DEVICE GRADE	MAXIMUM OUTPUT CHANGE - mV	
	0 TO +70°C	-55°C TO +125°C
AD587J	14.00	
AD587K	7.00	
AD587L	3.50	
AD587S		36.00
AD587T		18.00
AD587U		9.00

Figure 10. Maximum Output Change in mV

NEGATIVE REFERENCE VOLTAGE FROM AN AD587

The AD587 can be used to provide a precision -10.000 V output as shown in Figure 11. The V_{IN} pin is tied to at least a $+3.5\text{ V}$ supply, the output pin is grounded, and the AD587 ground pin is connected through a resistor, R_S , to a -15 V supply. The -10 V output is now taken from the ground pin (Pin 4) instead of V_{OUT} . It is essential to arrange the output load and the supply resistor R_S so that the net current through the AD587 is between 2.5 mA and 10.0 mA . The temperature characteristics and long-term stability of the device will be essentially the same as that of a unit used in the standard $+10\text{ V}$ output configuration.

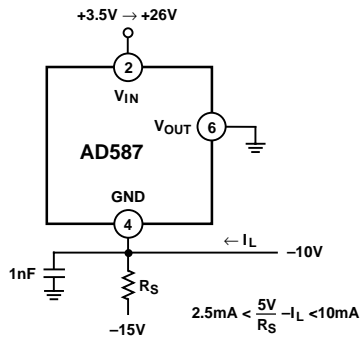

Figure 11. AD587 as a Negative 10 V Reference

USING THE AD587 WITH CONVERTERS

The AD587 is an ideal reference for a wide variety of 8-, 12-, 14- and 16-bit A/D and D/A converters. Several representative examples follow.

10 V REFERENCE WITH MULTIPLYING CMOS D/A OR A/D CONVERTERS

The AD587 is ideal for applications with 10- and 12-bit multiplying CMOS D/A converters. In the standard hookup, as shown in Figure 12, the AD587 is paired with the AD7545 12-bit multiplying DAC and the AD711 high-speed BiFET Op Amp. The amplifier DAC configuration produces a unipolar 0 V to -10 V output range. Bipolar output applications and other operating details can be found on the individual product data sheets.

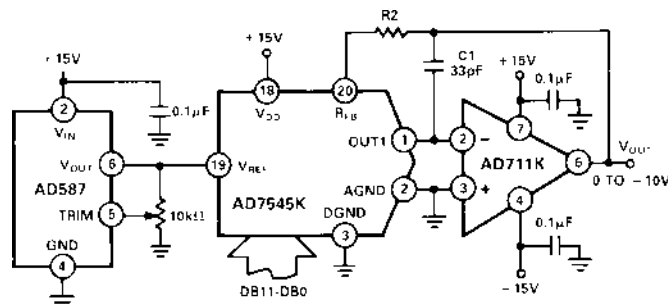

Figure 12. Low Power 12-Bit CMOS DAC Application

The AD587 can also be used as a precision reference for multiple DACs. Figure 13 shows the AD587, the AD7628 dual DAC and the AD712 dual op amp hooked up for single supply operation to produce 0 V to -10 V outputs. Because both DACs are on the same die and share a common reference and output op amps; the DAC outputs will exhibit similar gain TCs.

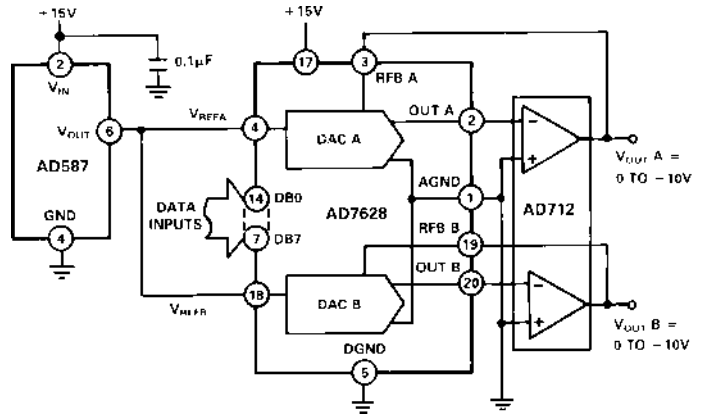

Figure 13. AD587 as a 10 V Reference for a CMOS Dual DAC

PRECISION CURRENT SOURCE

The design of the AD587 allows it to be easily configured as a current source. By choosing the control resistor R_C in Figure 14, you can vary the load current from the quiescent current (2 mA typically) to approximately 10 mA .

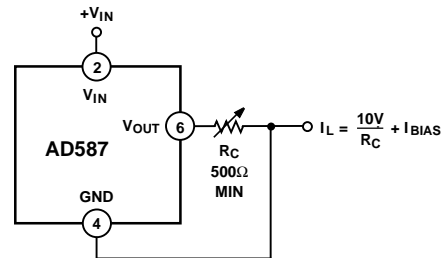

Figure 14. Precision Current Source

AD587

PRECISION HIGH CURRENT SUPPLY

For higher currents, the AD587 can easily be connected to a power PNP or power Darlington PNP device. The circuit in Figure 15 can deliver up to 4 amps to the load. The 0.1 μF

capacitor is required only if the load has a significant capacitive component. If the load is purely resistive, improved high frequency supply rejection results can be obtained by removing the capacitor.

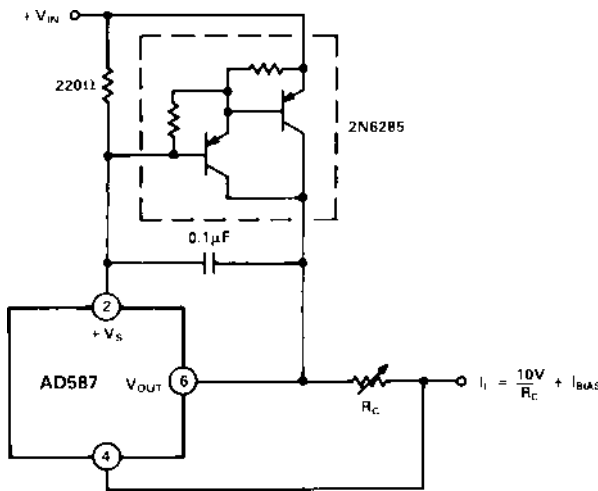

Figure 15a. Precision High-Current Current Source

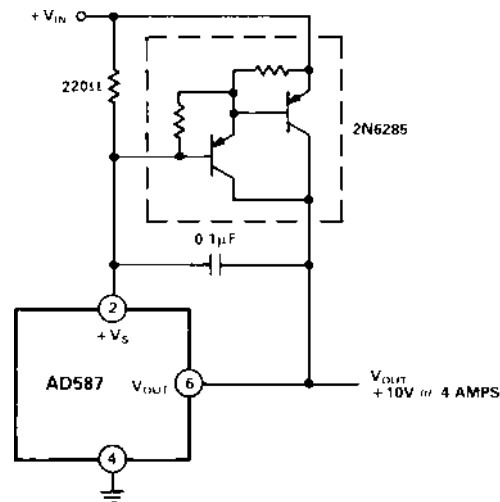
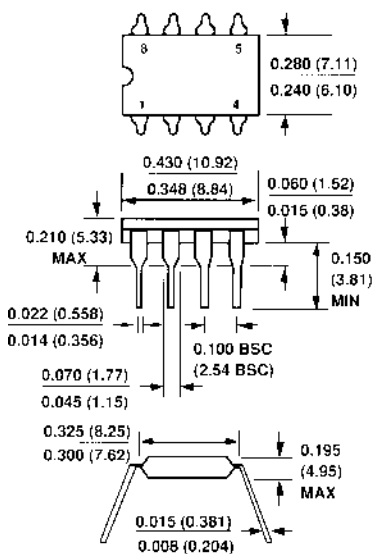

Figure 15b. Precision High-Current Voltage Source

OUTLINE DIMENSIONS

Dimensions shown in inches and (mm).

Mini-DIP (N-8) Package



Cerdip (Q-8) Package

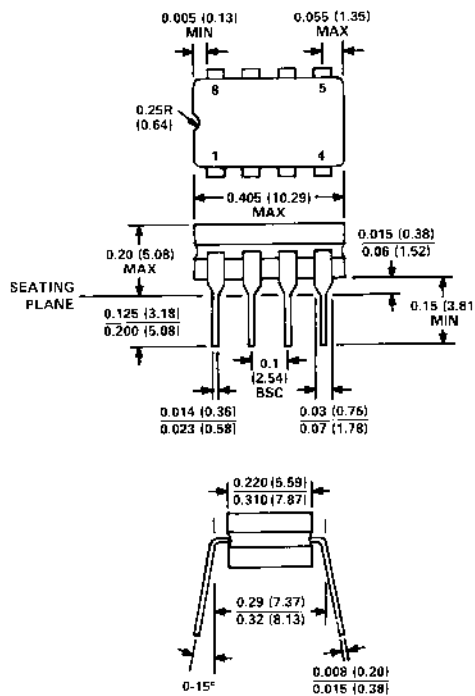

Small Outline (R-8) Package

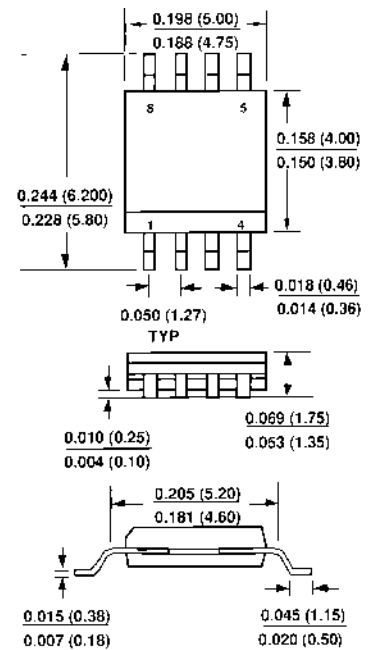

C1136a-0-2/00 (rev. D)

PRINTED IN U.S.A.