

Ejector Style Header

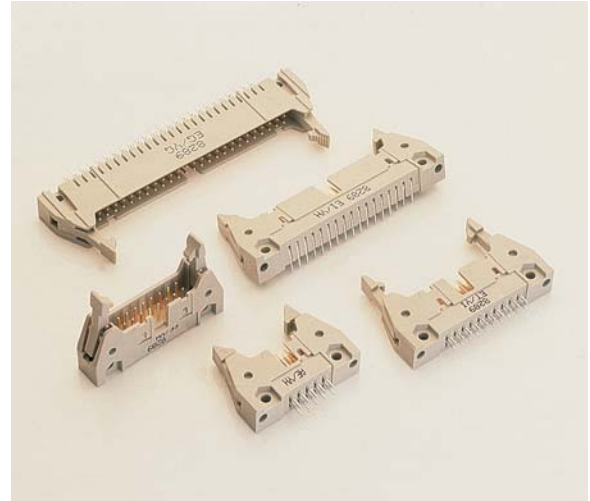

Series 8289

Available in industry standard sizes of 10-64 positions, they mate to AVX Series 8290 IDC sockets, as well as other industry compatible connectors. Solder or press-fit contacts are available in either straight or right angle formats. The four wall design and optional molded in polarizing keys ensure positive polarization without pin loss. Latch/eject levers can also be specified to suit the mating Series 8290 socket, either with or without strain relief. Stand-off are incorporated to facilitate flux washing and de-gassing.



TECHNICAL SPECIFICATION

Material:

Molding - UL94VO rated glass filled grey polyester

Contact - Phosphor bronze

Contact Plating:

Selective gold over nickel plating on the mating face, pure tin in IDC section

Latch/Eject Levers

Part Numbers when ordered separately.

Long (For 8290 socket with strain relief) 60 8289 6301 00 000
Short (For 8290 socket without strain relief) 60 8289 6302 00 000

Current Rating:

1 ampere at 70°C maximum ambient

Voltage Rating:

350V DC or AC peak

Contact Resistance:

Initially 10 milliohms maximum

Dielectric Withstanding Voltage:

1050 DC or AC peak

Insulation Resistance:

>1000 megohms

Operating Temperature:

-55°C to +125°C

UL File No. E90723

CSA File No. 1255749

ORDERING CODE

00	8289	050	002	1	1	1
Connector Code Prefix	Series Number	Number of Contacts	Contact Termination	Latch/Eject Lever	Plating	Polarization
00 = Standard		010 = 10 position 014 = 14 position 016 = 16 position 020 = 20 position 026 = 26 position 034 = 34 position 040 = 40 position 050 = 50 position 060 = 60 position 064 = 64 position	002 = Straight PC Tail for 2.4mm PCB - 0.142" (3.60mm) 004 = Right Angle PC Tail for 2.4mm PCB - 0.142" (3.60mm) 006 = Straight PC Tail for 1.6mm PCB - 0.110" (2.80mm) 007 = Right Angle PCB Tail for 1.6mm PCB - 0.110" (2.80mm) 009 = Press-Fit PC Tail 2.4/3.2mm PCB - 0.209" (4.5mm)	0 = No Latch/Eject Lever 1 = Latch/Eject Lever for use with Series 8290 with strain relief 2 = Latch/Eject Lever for use with Series 8290 without strain relief	1 = Selective Plating 30µ" Gold over Nickel 4 = Selective Plating 10µ" Gold over Nickel	1 = Type A BS9525 & BT224 Dual Height molding in polarizing key/keys 3 = No Polarizing key/keys - Standard

Ejector Style Header



Series 8289

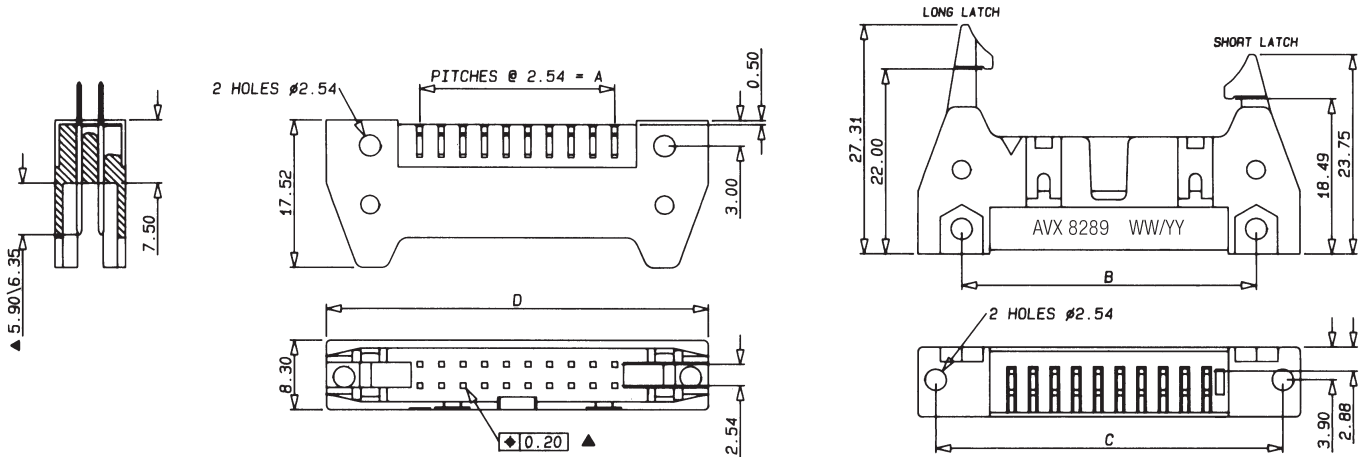

CONTACT VARIATIONS

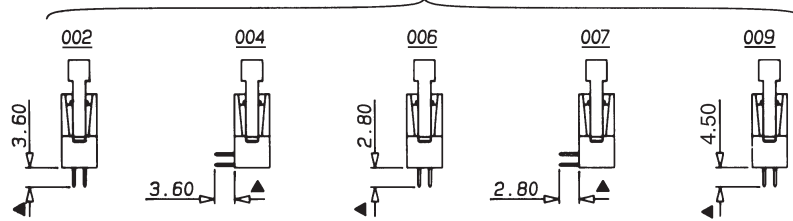

TAIL LENGTH TOLERANCES STANDARD ± 0.30 mm.

▲ ± 0.20 POSITIONAL TOLERANCE OF TAILS

BOARD HOLE DETAILS

VIEWED FROM PIN SIDE

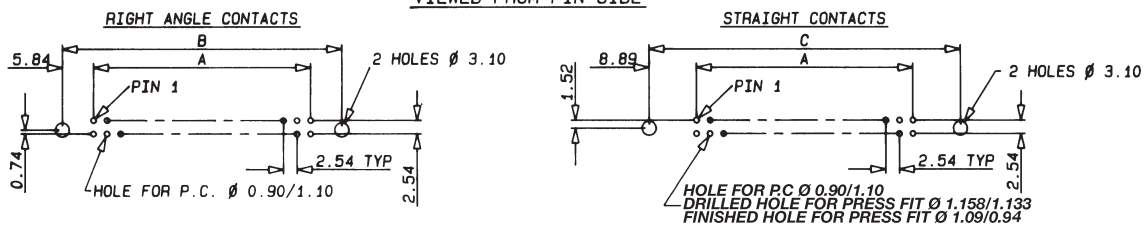

DIMENSIONS: millimeters (inches)

No. of Ways	A	B	C	D
10	10.16 (.040)	21.84 (.860)	27.94 (1.10)	32.11 (1.26)
14	15.24 (.060)	26.92 (1.06)	33.02 (1.30)	37.19 (1.46)
16	17.78 (.070)	29.46 (1.16)	35.56 (1.40)	39.73 (1.56)
20	22.86 (.090)	34.54 (1.36)	40.64 (1.60)	44.81 (1.76)
26	30.48 (1.20)	42.16 (1.66)	40.64 (1.90)	52.43 (2.06)
34	40.64 (1.60)	52.32 (2.06)	58.42 (2.30)	62.59 (2.46)
40	48.26 (1.90)	59.94 (2.36)	66.04 (2.60)	70.21 (2.76)
50	60.96 (2.40)	72.64 (2.86)	78.74 (3.10)	82.91 (3.26)
60	73.66 (2.90)	85.34 (3.36)	91.44 (3.60)	95.61 (3.76)
64	78.74 (3.10)	90.42 (3.56)	96.52 (3.80)	100.69 (3.96)

