



Aluminum Electrolytic Capacitors

Snap-in capacitors

Series/Type: B41252

Date: April 1, 2014

© EPCOS AG 2015. Reproduction, publication and dissemination of this publication, enclosures hereto and the information contained therein without EPCOS' prior express consent is prohibited.

EPCOS AG is a TDK Group Company.

General-purpose grade capacitors 通用级电容器

Applications 应用

- Switch mode power supplies in industrial electronics
工业电子产品中的开关电源

Features 特点

- RoHS-compatible
符合RoHS要求
- High ripple current capability
耐高纹波电流能力
- Useful life of 2000h at 105 °C
105 °C 2000h使用寿命

Construction 结构

- Aluminum case, fully insulated
铝质外壳，整体绝缘
- Minus pole marking on the insulating sleeve
绝缘套管上标注负极
- Overload protection by safety vent on the base
底部安全阀过载保护

Specifications and characteristics in brief

规格性能参数一览表

Rated voltage V_R 额定电压 V_R	10...100 V DC					
Surge voltage V_S 浪涌电压 V_S	$1.15 \cdot V_R$					
Operating temperature range 工作温度范围	-40 °C...+105 °C					
Rated capacitance C_R 额定容量 C_R (20 °C, 120 Hz)	820...56000 μ F					
Capacitance tolerance 电容公差	$\pm 20\%$ M					
Dissipation factor(max.) 损耗正切角(最大值) 20°C, 120Hz.	V_R (V DC)	10	16	25	35...50	63...100
	$\tan\delta$	0.45	0.35	0.3	0.2	0.15
Leakage current I_{leak} (20 °C, after 5 minutes) 漏电流 I_{leak} (20 °C, 5分钟后)	$I_{leak} \leq 0.02 \mu A \cdot \left(\frac{C_R}{\mu F} \cdot \frac{V_R}{V} \right)$					
Low temperature stability 低温稳定性 (max impedance ratio) (最大阻抗比率) (120Hz)	V_R (V DC)	10...16	25	35	50...63	80...100
	Z (-25 °C) Z (+20 °C)	4	3	3	2	2
	Z (-40 °C) Z (+20 °C)	15	10	8	6	5
Useful life 使用寿命 (105 °C, $V_R, I_{AC,R}$)	2000 h	Requirements 要求:				
		$\Delta C/C \leq \pm 20\%$ of initial value 初始值的 $\pm 20\%$				
		$\tan\delta \leq 2$ times initial specified limit 2倍初始规定值				
		$I_{leak} \leq$ initial specified limit 初始规定值				
Shelf life 储存寿命	After storage for 1000 h at 105 °C, the capacitors shall meet the requirement of useful life test after reforming process. After test: V_R to be applied for 30 minutes, 24 to 48 hours before measurement. 105°C高温贮存1000小时, 并预处理后, 电容器必须符合使用寿命测试中对其电性能的要求。预处理方法: 先加额定电压充电30分钟, 恢复24至48小时后再测试。					
Frequency multiplier for rated ripple current 额定纹波电流频率系数	V_R (V DC)	50 Hz	120 Hz	1 kHz	10 kHz	20 kHz
	10...50	0.95	1.00	1.10	1.15	1.15
	63...100	0.95	1.00	1.16	1.30	1.33
Temperature multiplier for rated ripple current 额定纹波电流温度系数	+40 °C	+55 °C	+70 °C	+85 °C	+105 °C	
	2.7	2.5	2.1	1.7	1.0	
Sectional specification 分规范	IEC 60384-4					

Dimensional drawing

snap-in standard terminals (6.0±1) mm
digit 15 of part number = 0

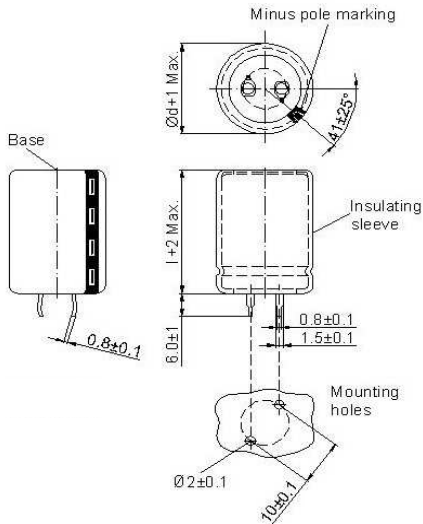

snap-in short terminals (4.0±0.5) mm
digit 15 of part number = 7

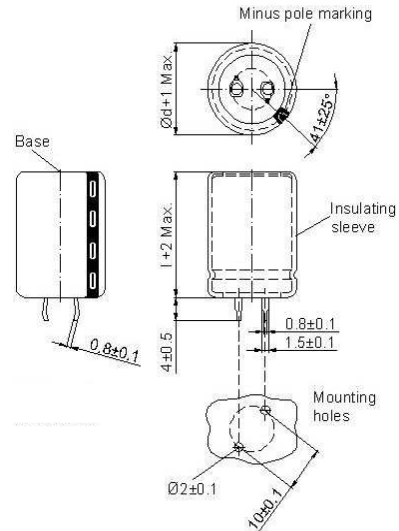

snap-in 3 terminals terminals (4.0±0.5) mm
digit 15 of part number = 2

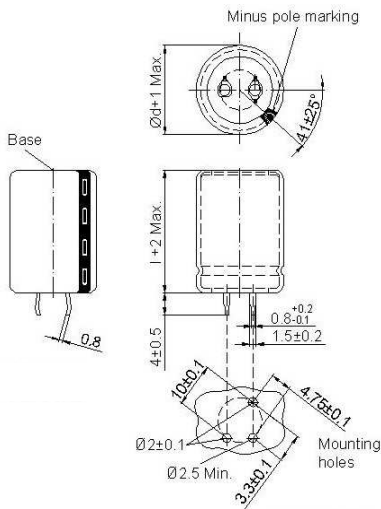

snap-in 4 terminal terminals (6.0±1) mm
digit 15 of part number = 4

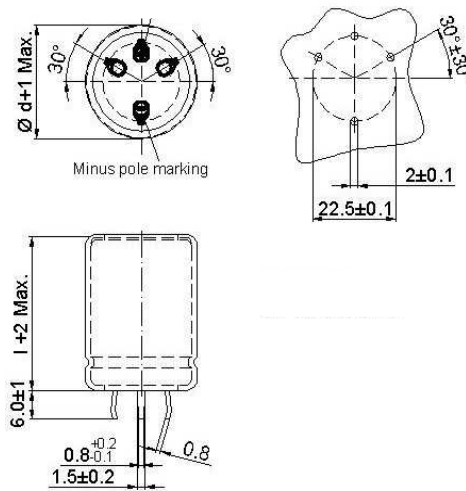

vibration-resistance terminals (4.5±1) mm
digit 15 of part number = 8

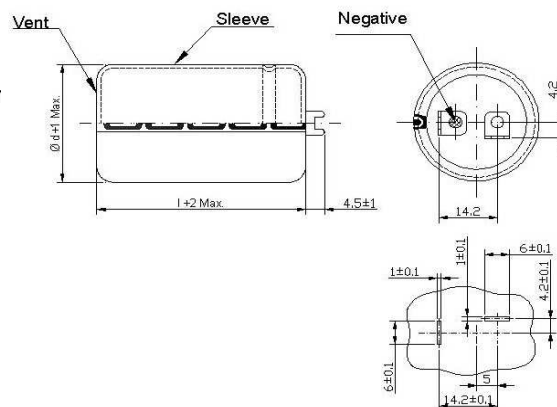

Technical dates and ordering codes

V_R	C_R	Case dimensions d × l mm	$I_{AC,R}$	Ordering code
V DC	120Hz 20 °C μF		120 Hz 105 °C A	
10	10000	22.0 × 25	2.17	B41252A3109M0*#
	12000	22.0 × 30	2.48	B41252A3129M0*#
	15000	22.0 × 35	2.83	B41252A3159M0*#
	15000	25.4 × 25	2.75	B41252B3159M0*#
	18000	22.0 × 35	3.00	B41252A3189M0*#
	18000	25.4 × 30	3.11	B41252B3189M0*#
	22000	22.0 × 40	3.35	B41252A3229M0*#
	22000	25.4 × 35	3.48	B41252B3229M0*#
	22000	30.0 × 25	3.38	B41252C3229M0*#
	27000	22.0 × 50	3.88	B41252A3279M0*#
	27000	25.4 × 40	3.87	B41252B3279M0*#
	27000	30.0 × 30	3.79	B41252C3279M0*#
	33000	25.4 × 45	4.26	B41252A3339M0*#
	33000	30.0 × 35	4.20	B41252B3339M0*#
	39000	25.4 × 50	4.60	B41252A3399M0*#
	39000	30.0 × 40	4.57	B41252B3399M0*#
	39000	35.0 × 30	4.46	B41252C3399M0*#
	47000	30.0 × 45	4.95	B41252A3479M0*#
	47000	35.0 × 35	4.87	B41252B3479M0*#
	56000	35.0 × 45	5.49	B41252A3569M0*#
16	8200	22.0 × 25	2.14	B41252A4828M0*#
	10000	22.0 × 30	2.48	B41252A4109M0*#
	10000	25.4 × 25	2.56	B41252B4109M0*#
	12000	22.0 × 35	2.80	B41252A4129M0*#
	12000	25.4 × 30	2.90	B41252B4129M0*#
	12000	30.0 × 25	2.97	B41252C4129M0*#
	15000	22.0 × 40	3.17	B41252A4159M0*#
	15000	25.4 × 35	3.29	B41252B4159M0*#
	15000	30.0 × 30	3.38	B41252C4159M0*#
	18000	22.0 × 45	3.50	B41252A4189M0*#
	18000	25.4 × 40	3.65	B41252B4189M0*#
	18000	30.0 × 30	3.57	B41252C4189M0*#
	22000	25.4 × 45	4.03	B41252A4229M0*#
	22000	30.0 × 35	3.98	B41252B4229M0*#

* = Insulation feature
0 = PVC sleeve
6 = PET sleeve

= Terminal style
0 = snap-in standard terminals (6.0±1) mm
2 = snap-in 3 terminals (4.0±0.5) mm
4 = snap-in 4 terminals (6.0±1) mm
7 = snap-in short terminals (4.0±0.5) mm
8 = vibration-resistance terminals (4.5±1) mm

Technical dates and ordering codes

V_R	C_R 120Hz 20 °C μF	Case dimensions d x l mm	$I_{AC,R}$ 120 Hz 105 °C A	Ordering code
16	27000	25.4 x 50	4.42	B41252A4279M0*#
	27000	30.0 x 40	4.39	B41252B4279M0*#
	27000	35.0 x 30	4.29	B41252C4279M0*#
	33000	30.0 x 45	4.79	B41252A4339M0*#
	33000	35.0 x 35	4.71	B41252B4339M0*#
	39000	30.0 x 50	5.16	B41252A4399M0*#
	39000	35.0 x 40	5.10	B41252B4399M0*#
	47000	35.0 x 45	5.50	B41252A4479M0*#
25	4700	22.0 x 25	1.73	B41252A5478M0*#
	5600	22.0 x 30	1.98	B41252A5568M0*#
	6800	22.0 x 30	2.14	B41252A5688M0*#
	8200	22.0 x 35	2.42	B41252A5828M0*#
	8200	25.4 x 30	2.50	B41252B5828M0*#
	10000	22.0 x 40	2.77	B41252A5109M0*#
	10000	25.4 x 35	2.88	B41252B5109M0*#
	12000	22.0 x 45	3.09	B41252A5129M0*#
	12000	25.4 x 40	3.22	B41252B5129M0*#
	12000	30.0 x 30	3.15	B41252C5129M0*#
	15000	25.4 x 45	3.62	B41252A5159M0*#
	15000	30.0 x 35	3.57	B41252B5159M0*#
	15000	35.0 x 30	3.65	B41252C5159M0*#
	18000	25.4 x 50	3.98	B41252A5189M0*#
	18000	30.0 x 40	3.95	B41252B5189M0*#
	18000	35.0 x 35	4.06	B41252C5189M0*#
22000	30.0 x 45	4.36	B41252A5229M0*#	
22000	35.0 x 35	4.28	B41252B5229M0*#	
27000	35.0 x 45	4.92	B41252A5279M0*#	
35	3300	22.0 x 25	1.26	B41252A7338M0*#
	3900	22.0 x 30	1.88	B41252B7398M0*#
	4700	22.0 x 35	2.14	B41252A7478M0*#
	4700	25.4 x 25	2.09	B41252B7478M0*#
	5600	22.0 x 35	2.29	B41252A7568M0*#
	5600	25.4 x 30	2.37	B41252B7568M0*#
	5600	30.0 x 25	2.43	B41252C7568M0*#

* = Insulation feature
 0 = PVC sleeve
 6 = PET sleeve

= Terminal style
 0 = snap-in standard terminals (6.0±1) mm
 2 = snap-in 3 terminals (4.0±0.5) mm
 4 = snap-in 4 terminals (6.0±1) mm
 7 = snap-in short terminals (4.0±0.5) mm
 8 = vibration-resistance terminals (4.5±1) mm

Technical dates and ordering codes

V_R	C_R 120Hz 20 °C μF	Case dimensions d x l mm	$I_{AC,R}$ 120 Hz 105 °C A	Ordering code
35	6800	22.0 x 40	2.61	B41252A7688M0*#
	6800	25.4 x 35	2.71	B41252B7688M0*#
	6800	30.0 x 30	2.79	B41252C7688M0*#
	8200	22.0 x 50	3.02	B41252A7828M0*#
	8200	25.4 x 40	3.02	B41252B7828M0*#
	8200	30.0 x 30	2.95	B41252C7828M0*#
	10000	25.4 x 45	3.43	B41252A7109M0*#
	10000	30.0 x 35	3.38	B41252B7109M0*#
	12000	25.4 x 50	3.78	B41252A7129M0*#
	12000	30.0 x 40	3.75	B41252B7129M0*#
	12000	35.0 x 30	3.67	B41252C7129M0*#
	15000	30.0 x 45	4.19	B41252A7159M0*#
	15000	35.0 x 35	4.12	B41252B7159M0*#
	18000	35.0 x 40	4.52	B41252A7189M0*#
	22000	35.0 x 45	4.95	B41252A7229M0*#
50	2700	22.0 x 30	1.94	B41252A6278M0*#
	3300	22.0 x 35	2.20	B41252A6338M0*#
	3900	22.0 x 40	2.52	B41252A6398M0*#
	3900	25.4 x 35	2.62	B41252B6398M0*#
	3900	30.0 x 25	2.54	B41252C6398M0*#
	4700	22.0 x 45	2.81	B41252A6478M0*#
	4700	25.4 x 40	2.93	B41252B6478M0*#
	4700	30.0 x 30	2.87	B41252C6478M0*#
	5600	22.0 x 50	3.11	B41252A6568M0*#
	5600	25.4 x 40	3.11	B41252B6568M0*#
	5600	30.0 x 35	3.21	B41252C6568M0*#
	6800	25.4 x 50	3.64	B41252A6688M0*#
	6800	30.0 x 40	3.61	B41252B6688M0*#
	6800	35.0 x 30	3.53	B41252C6688M0*#
	8200	30.0 x 45	3.94	B41252A6828M0*#
	8200	35.0 x 35	3.87	B41252B6828M0*#

* = Insulation feature

0 = PVC sleeve

6 = PET sleeve

= Terminal style

0 = snap-in standard terminals (6.0±1) mm

2 = snap-in 3 terminals (4.0±0.5) mm

4 = snap-in 4 terminals (6.0±1) mm

7 = snap-in short terminals (4.0±0.5) mm

8 = vibration-resistance terminals (4.5±1) mm

Technical dates and ordering codes

V_R	C_R 120Hz 20 °C μF	Case dimensions d x l mm	$I_{AC,R}$ 120 Hz 105 °C A	Ordering code
50	10000	30.0 x 50	4.42	B41252A6109M0*#
	10000	35.0 x 40	4.37	B41252B6109M0*#
	12000	35.0 x 45	4.78	B41252A6129M0*#
	15000	35.0 x 50	5.24	B41252A6159M0*#
63	1200	22.0 x 25	1.37	B41252A8128M0*#
	1500	22.0 x 30	1.50	B41252A8158M0*#
	1500	25.4 x 25	1.54	B41252B8158M0*#
	1800	22.0 x 30	1.64	B41252A8188M0*#
	1800	25.4 x 25	1.69	B41252B8188M0*#
	2200	22.0 x 35	1.86	B41252A8228M0*#
	2200	25.4 x 30	1.92	B41252B8228M0*#
	2700	22.0 x 40	2.17	B41252A8278M0*#
	2700	25.4 x 30	2.13	B41252B8278M0*#
	2700	30.0 x 25	2.18	B41252C8278M0*#
	3300	22.0 x 50	2.53	B41252A8338M0*#
	3300	25.4 x 40	2.53	B41252B8338M0*#
	3300	30.0 x 30	2.48	B41252C8338M0*#
	3900	25.4 x 45	2.88	B41252A8398M0*#
	3900	30.0 x 35	2.84	B41252B8398M0*#
	4700	25.4 x 50	3.20	B41252A8478M0*#
	4700	30.0 x 40	3.17	B41252B8478M0*#
	4700	35.0 x 30	3.10	B41252C8478M0*#
	5600	30.0 x 45	3.51	B41252A8568M0*#
	5600	35.0 x 35	3.46	B41252B8568M0*#
6800	30.0 x 50	3.92	B41252A8688M0*#	
6800	35.0 x 40	3.88	B41252B8688M0*#	
8200	35.0 x 45	4.22	B41252A8828M0*#	
10000	35.0 x 50	4.74	B41252A8109M0*#	

* = Insulation feature

0 = PVC sleeve

6 = PET sleeve

= Terminal style

0 = snap-in standard terminals (6.0±1) mm

2 = snap-in 3 terminals (4.0±0.5) mm

4 = snap-in 4 terminals (6.0±1) mm

7 = snap-in short terminals (4.0±0.5) mm

8 = vibration-resistance terminals (4.5±1) mm

Technical dates and ordering codes

V_R	C_R	Case dimensions d x l mm	$I_{AC,R}$	Ordering code
V DC	120Hz 20 °C μF		120 Hz 105 °C A	
80	820	22.0 x 25	1.37	B41252A0827M0*#
	1000	22.0 x 30	1.62	B41252A0108M0*#
	1000	25.4 x 25	1.67	B41252B0108M0*#
	1200	22.0 x 30	1.67	B41252A0128M0*#
	1200	25.4 x 25	1.72	B41252B0128M0*#
	1500	22.0 x 35	1.98	B41252A0158M0*#
	1500	25.4 x 30	2.05	B41252B0158M0*#
	1800	22.0 x 40	2.28	B41252A0188M0*#
	1800	25.4 x 35	2.37	B41252B0188M0*#
	1800	30.0 x 25	2.30	B41252C0188M0*#
	2200	22.0 x 45	2.51	B41252A0228M0*#
	2200	25.4 x 35	2.49	B41252B0228M0*#
	2200	30.0 x 30	2.56	B41252C0228M0*#
	2700	25.4 x 45	3.03	B41252A0278M0*#
	2700	30.0 x 35	2.99	B41252B0278M0*#
	3300	25.4 x 50	3.33	B41252A0338M0*#
	3300	30.0 x 40	3.30	B41252B0338M0*#
	3300	35.0 x 30	3.23	B41252C0338M0*#
	3900	30.0 x 45	3.75	B41252A0398M0*#
	3900	35.0 x 35	3.69	B41252B0398M0*#
	4700	30.0 x 50	4.10	B41252A0478M0*#
	4700	35.0 x 40	4.06	B41252B0478M0*#
	5600	35.0 x 45	4.44	B41252A0568M0*#
	6800	35.0 x 50	4.90	B41252A0688M0*#

* = Insulation feature
0 = PVC sleeve
6 = PET sleeve

= Terminal style
0 = snap-in standard terminals (6.0±1) mm
2 = snap-in 3 terminals (4.0±0.5) mm
4 = snap-in 4 terminals (6.0±1) mm
7 = snap-in short terminals (4.0±0.5) mm
8 = vibration-resistance terminals (4.5±1) mm

Technical dates and ordering codes

V_R	C_R 120Hz 20 °C μF	Case dimensions d x l mm	$I_{AC,R}$ 120 Hz 105 °C A	Ordering code
100	820	22.0 x 30	1.46	B41252A9827M0*#
	820	25.4 x 25	1.51	B41252B9827M0*#
	1000	22.0 x 35	1.71	B41252A9108M0*#
	1000	25.4 x 30	1.77	B41252B9108M0*#
	1200	22.0 x 40	1.86	B41252A9128M0*#
	1200	25.4 x 35	1.94	B41252B9128M0*#
	1200	30.0 x 25	1.88	B41252C9128M0*#
	1500	22.0 x 45	2.18	B41252A9158M0*#
	1500	25.4 x 40	2.28	B41252B9158M0*#
	1500	30.0 x 30	2.23	B41252C9158M0*#
	1800	25.4 x 45	2.61	B41252A9188M0*#
	1800	30.0 x 35	2.57	B41252B9188M0*#
	2200	25.4 x 50	2.85	B41252A9228M0*#
	2200	30.0 x 40	2.83	B41252B9228M0*#
	2200	35.0 x 30	2.76	B41252C9228M0*#
	2700	30.0 x 45	3.27	B41252A9278M0*#
	2700	35.0 x 35	3.22	B41252B9278M0*#
	3300	30.0 x 50	3.59	B41252A9338M0*#
	3300	35.0 x 40	3.55	B41252B9338M0*#
	3900	35.0 x 45	4.03	B41252A9398M0*#
4700	30.0 x 55	4.40	B41252B9478M0*#	
4700	35.0 x 50	4.40	B41252A9478M0*#	
5600	35.0 x 60	4.78	B41252A9568M0*#	

* = Insulation feature

0 = PVC sleeve

6 = PET sleeve

= Terminal style

0 = snap-in standard terminals (6.0±1) mm

2 = snap-in 3 terminals (4.0±0.5) mm

4 = snap-in 4 terminals (6.0±1) mm

7 = snap-in short terminals (4.0±0.5) mm

8 = vibration-resistance terminals (4.5±1) mm

Bar code label and marking of the capacitor 条形码标签和电容器标签

Below is an example of bar code label on package:

以下为包装箱上条形码标签示例:

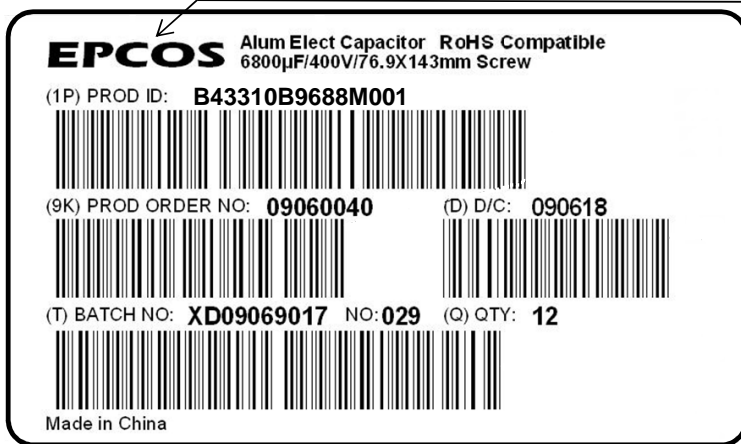

Brand 品牌

- (1P) Ordering code 订购代码
- (9K) Product order number 订单号
- (D) Date code (yywwdd) 日期代码 (年月日)
- (T) Batch number 批号
- (Q) Quantity 数量

The two examples below shows how the capacitor sleeve are marked according to case height:

以下两个示例说明不同壳体高度电容器套管上的标签内容:

Case height

壳体高度

20mm		<p>Brand 品牌</p> <p>Part number (ordering code) 料号 (订购代码)</p> <p>Rated capacitance, tolerance, rated voltage, 额定电容、容差、额定电压</p> <p>Climatic category, month and year of production 气候分类、月.年 (生产日期)</p>
25mm		<p>Brand 品牌</p> <p>Part number (ordering code) 料号 (订购代码)</p> <p>Rated capacitance, tolerance, rated voltage, 额定电容、容差、额定电压</p> <p>Climatic category 气候分类</p> <p>Month and year of production 月.年 (生产日期)</p>
>25mm		<p>Brand 品牌</p> <p>Part number (ordering code) 料号 (订购代码)</p> <p>Rated capacitance, tolerance, rated voltage, 额定电容、容差、额定电压</p> <p>Climatic category 气候分类</p> <p>Month and year of production 月.年 (生产日期)</p>

The climatic category is specified according to IEC 60068-1. If there is not enough space on the case, the following codes may be used:

气候类别符合IEC 60068 - 1。如果壳体上没有足够空间，可使用以下代码:

E.g.: 40/085/56, in coded form, would read GPF 例如: 40/085/56的代码形式为GPF

1st letter (lower category temperature) 首字母 (下限类别温度)

Code letter 字母代码	F	G	H
Temperature 温度 (° C)	-55	-40	-25

2nd letter (upper category temperature) 第二字母 (上限类别温度)

Code letter 代码字母	K	M	P	S	U
Temperature 温度 (° C)	+125	+105(+100)	+85	+70	+60

3rd letter (humidity) 第三字母 (湿度)

Letter F: withstands IEC60068-2-78 Cab (damp heat, steady state), test duration 56 days.

字母F: 经受IEC 60068-2-78试验箱 (湿热、恒稳态), 试验周期56天。

Important notes

The following applies to all products named in this publication:

1. Some parts of this publication contain **statements about the suitability of our products for certain areas of application**. These statements are based on our knowledge of typical requirements that are often placed on our products in the areas of application concerned. We nevertheless expressly point out **that such statements cannot be regarded as binding statements about the suitability of our products for a particular customer application**. As a rule we are either unfamiliar with individual customer applications or less familiar with them than the customers themselves. For these reasons, it is always ultimately incumbent on the customer to check and decide whether a product with the properties described in the product specification is suitable for use in a particular customer application.
2. We also point out that **in individual cases, a malfunction of electronic components or failure before the end of their usual service life cannot be completely ruled out in the current state of the art, even if they are operated as specified**. In customer applications requiring a very high level of operational safety and especially in customer applications in which the malfunction or failure of an electronic component could endanger human life or health (e.g. in accident prevention or life-saving systems), it must therefore be ensured by means of suitable design of the customer application or other action taken by the customer (e.g. installation of protective circuitry or redundancy) that no injury or damage is sustained by third parties in the event of malfunction or failure of an electronic component.
3. **The warnings, cautions and product-specific notes must be observed.**
4. In order to satisfy certain technical requirements, **some of the products described in this publication may contain substances subject to restrictions in certain jurisdictions (e.g. because they are classed as hazardous)**. Useful information on this will be found in our Material Data Sheets on the Internet (www.tdk-electronics.tdk.com/material). Should you have any more detailed questions, please contact our sales offices.
5. We constantly strive to improve our products. Consequently, **the products described in this publication may change from time to time**. The same is true of the corresponding product specifications. Please check therefore to what extent product descriptions and specifications contained in this publication are still applicable before or when you place an order.

We also **reserve the right to discontinue production and delivery of products**. Consequently, we cannot guarantee that all products named in this publication will always be available. The aforementioned does not apply in the case of individual agreements deviating from the foregoing for customer-specific products.
6. Unless otherwise agreed in individual contracts, **all orders are subject to our General Terms and Conditions of Supply**.
7. **Our manufacturing sites serving the automotive business apply the IATF 16949 standard**. The IATF certifications confirm our compliance with requirements regarding the quality management system in the automotive industry. Referring to customer requirements and customer specific requirements ("CSR") TDK always has and will continue to have the policy of respecting individual agreements. Even if IATF 16949 may appear to support the acceptance of unilateral requirements, we hereby like to emphasize that **only requirements mutually agreed upon can and will be implemented in our Quality Management System**. For clarification purposes we like to point out that obligations from IATF 16949 shall only become legally binding if individually agreed upon.
8. The trade names EPCOS, CeraCharge, CeraDiode, CeraLink, CeraPad, CeraPlas, CSMP, CTVS, DeltaCap, DigiSiMic, ExoCore, FilterCap, FormFit, LeaXield, MiniBlue, MiniCell, MKD, MKK, MotorCap, PCC, PhaseCap, PhaseCube, PhaseMod, PhiCap, PowerHap, PQSine, PQvar, SIFERRIT, SIFI, SIKOREL, SilverCap, SIMDAD, SiMic, SIMID, SineFormer, SIOV, ThermoFuse, WindCap are **trademarks registered or pending** in Europe and in other countries. Further information will be found on the Internet at www.tdk-electronics.tdk.com/trademarks.

Release 2018-10