

DESCRIPTION

Demonstration circuit 1209A is a Micropower, low dropout linear regulator featuring LT[®]3060, which comes in an 8-lead TSOT23 or 2mmX2mm DFN package. The DC1209A has an input voltage range from 2.1V to 45V, and is capable of delivering up to 100mA output current. An external capacitor at REF/BYP pin provides low noise reference and programmable output soft-start functionality. The LT3060's quiescent current is merely 40uA and provides fast transient response with a minimum 2.2uF output capacitor. The DC1209A is ideal for supplying power to battery-powered systems, automotive, in-

dustrial, avionic power supplies and portable instruments.

The LT3060 datasheet gives a complete description of the part, operation and application information. The datasheet should be read in conjunction with this quick start guide for working on or modifying the demo circuit 1209A.

Design files for this circuit board are available. Call the LTC factory.

 , LTC, LTM, LT and uModule are registered trademarks of Linear Technology Corporation. All other trademarks are the property of their respective owners.

Table 1. Performance Summary ($T_A = 25^{\circ}\text{C}$)

PARAMETER	CONDITION	VALUE
Minimum Input Voltage		2.1V
Maximum Input Voltage		45V
Output Voltage	Vin=20V, Iout=100mA	1.2V \pm 3%
	Vin=20V, Iout=100mA	1.5V \pm 3%
	Vin=20V, Iout=100mA	1.8V \pm 3%
	Vin=20V, Iout=100mA	2.0V \pm 3%
	Vin=20V, Iout=100mA	2.5V \pm 3%
	Vin=20V, Iout=100mA	3.3V \pm 3%
	Vin=20V, Iout=100mA	5.0V \pm 3%
Maximum Output Current		100mA
Quiescent Current	V _{SHDN} =0V	<1 μ A

QUICK START PROCEDURE

The DC1209A is easy to set up to evaluate the performance of the LT3060. Refer to Figure 1. for proper measurement equipment setup and following the procedures below:

1. Before proceeding to test, insert jumper JP7 into the OFF position, and use VOUT Select jumper JP1 for the desired output voltage 1.2V, 1.8V, 2.0V, 2.5V, 3.3V or 5.0V. If the output voltage is different from the above values, use the USER option and install a resistor R8. Select R8 according to the following equation: $R_8 = \left(\frac{V_{OUT}}{0.6V} - 1 \right) \cdot 124K$.

Assume 1.2V is the desired output for the following evaluations.

2. Apply 2.1V across Vin (to Gnd). Insert jumper JP7 into the ON position. Draw 100mA of load current. The measured Vout should be $1.2V \pm 3%$ (1.164V to 1.236V).
3. Vary the input voltage from 2.1V to 45V and the load current from no load to 100mA. Vout should measure $1.2V \pm 3%$ (1.164V to 1.236V).

Note: Make sure the power dissipation is limited below the thermal limit. Maximum junction temperature also limits the operation conditions. For instance, the junction temperature reaches 125C at room temperature with 2.5W dissipation on demo board 1209A.

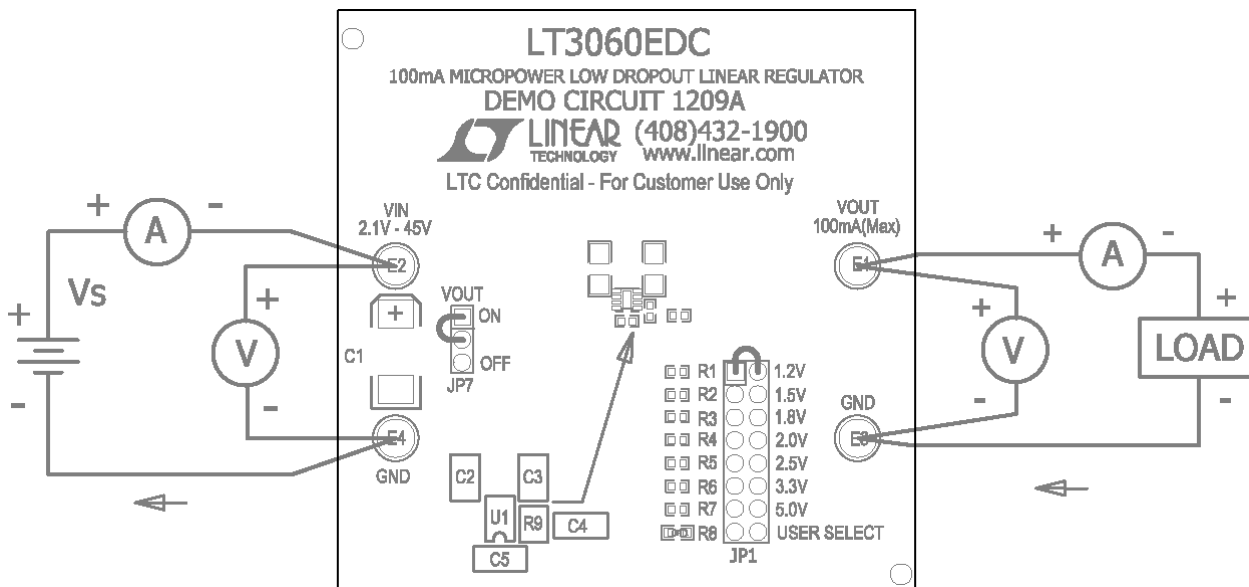

Figure 1. Proper Measurement Equipment Setup

