

## Features

- Compliant with IEEE802.3ab Draft Standards for 1000 Base-T
- Designed for Long Haul Gigabit Ethernet 10/100/1000 Base-T Full Duplex applications
- Low profile surface mount packaging designed for reflow process (245 °C peak)
- Supports 4 pairs of Category 5 UTP cables



This series is  $\text{Sd M\&R/U}$  not recommended for new designs.

- RoHS compliant\*

## PT61023L LAN 10/100/1000 Base-T Transformer Modules

### Electrical Specifications @ 25 °C

Inductance.....	350 $\mu$ H min.
with 8 mA DC bias @ 100 KHz, 0.2 V	
Leakage Inductance.....	0.50 $\mu$ H max.
@ 100 KHz, 0.2 V	
Interwinding Capacitance.....	25 pF typ.
@ 100 KHz, 0.2 V	
DC Resistance.....	0.90 $\Omega$ max.
Insertion Loss.....	0.3-100 MHz
	-1.1 dB max.
Return Loss (dB min.)	
0.3-30 MHz.....	-18
40 MHz.....	-14.4
50 MHz.....	-13.1
60-80 MHz.....	-12
Cross Talk (dB min.)	
0.3-30 MHz.....	-35
60-100 MHz.....	-28
Common Mode Rejection (dB min.)	
0.3-30 MHz.....	-40
60 MHz.....	-35
80-100 MHz.....	-30
Turns Ratio.....	1 CT:1 $\pm$ 5 %
Isolation Hi-Pot.....	1500 VAC 1 mA 1 sec.
Operating Temperature	
.....	0° C to +70 °C

### Packaging Specifications

Tape & Reel..... 500 pcs/reel

### How To Order

**PT61023E L**

Model \_\_\_\_\_  
Termination \_\_\_\_\_  
L = Tin only (RoHS Compliant)

### Electrical Schematic

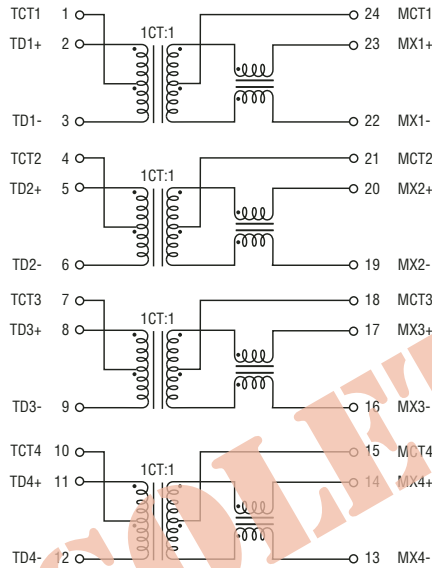

### Product Dimensions

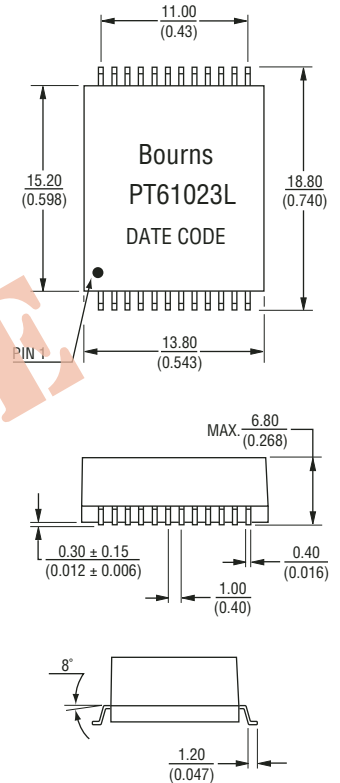

### Recommended Layout

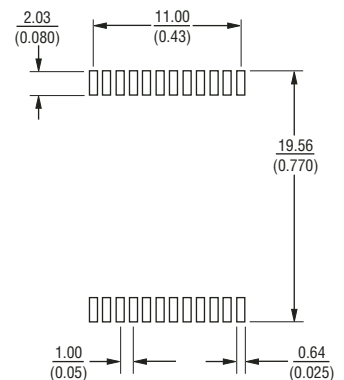

DIMENSIONS:  $\frac{\text{MM}}{\text{(INCHES)}}$

TOLERANCES:  $\pm \frac{0.25}{(.010)}$

REV. 05/13

\*RoHS Directive 2002/95/EC Jan. 27, 2003 including annex and RoHS Recast 2011/65/EU June 8, 2011.  
 Specifications are subject to change without notice.

The device characteristics and parameters in this data sheet can and do vary in different applications and actual device performance may vary over time.  
 Users should verify actual device performance in their specific applications.