

### FEATURES

- 10 Volt Output
- Guaranteed Long-Term Stability ..... 50ppm/1000 Hrs Max
- Excellent Temperature Stability ..... 8.5ppm/°C Max
- Low Noise ..... 30 $\mu$ V<sub>p-p</sub> Max
- Low Supply Current ..... 1.4mA Max
- Wide Input Voltage Range ..... 12V to 40V
- High Load-Driving Capability ..... 20mA
- Short-Circuit Proof
- Processed Per MIL-STD-883

### PIN CONNECTIONS & ORDERING INFORMATION

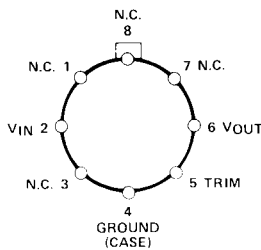

**TO-99 (J-Suffix)**  
REF-10AJ/883  
REF-10BJ/883

### GENERAL DESCRIPTION

The REF-10 precision voltage reference provides a stable +10V output that can be adjusted over a  $\pm 3\%$  range with minimal effect on temperature stability. Long-term drift is

guaranteed at 50ppm/1000 hrs. maximum. Single-supply operation over an input voltage range of 12V to 40V, low current drain of 1 mA, and excellent temperature stability are achieved with an improved bandgap design. Low cost, low noise, and low power make the REF-10 an excellent choice whenever a stable voltage reference is required. Applications include D/A and A/D converters, portable instrumentation, and digital voltmeters. For +5V precision voltage references, see the REF-05 data sheet.

### LONG-TERM DRIFT PLOT (Average of 20 Devices)

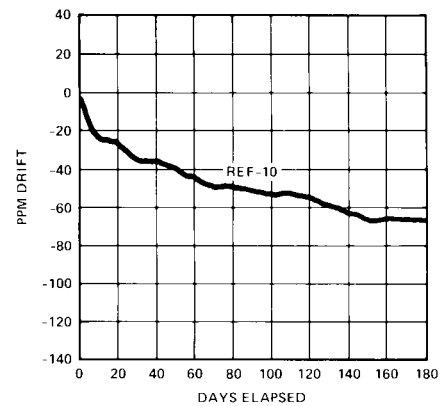

### SIMPLIFIED SCHEMATIC

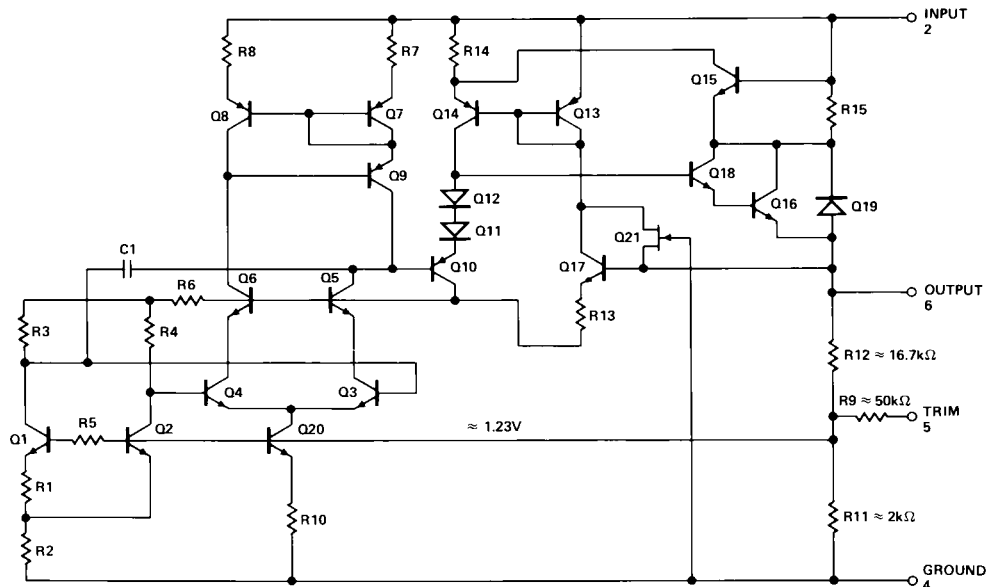

REV. B

Information furnished by Analog Devices is believed to be accurate and reliable. However, no responsibility is assumed by Analog Devices for its use, nor for any infringements of patents or other rights of third parties which may result from its use. No license is granted by implication or otherwise under a patent or patent rights of Analog Devices.

One Technology Way, P.O. Box 9106, Norwood, MA 02062-9106, U.S.A.  
Tel: 617/329-4700 Fax: 617/326-8703 Twx: 710/394-6577  
Telex: 924491 Cable: ANALOG NORWOODMASS

# REF-10

## ABSOLUTE MAXIMUM RATINGS (Note 1)

Input Voltage	
REF-10A, B	40V
Output Short-Circuit Duration (to Ground or $V_{IN}$ )	Indefinite
Storage Temperature Range	-65°C to +150°C
Lead Temperature (Soldering, 60 sec)	300°C

## Operating Temperature Range

REF-10A, REF-10B ..... -55°C to +125°C

PACKAGE TYPE	$\theta_{JA}$ (NOTE 2)	$\theta_{JC}$	UNITS
TO-99 (J)	170	24	°C/W

### NOTES:

- Derate at 7.1mW/°C above 80°C ambient temperature for TO-99 package.
- $\theta_{JA}$  is specified for worst case mounting conditions, i.e.,  $\theta_{JA}$  is specified for device in socket for TO package.

## ELECTRICAL CHARACTERISTICS at $V_{IN} = +15V$ , $T_A = 25^\circ C$ , unless otherwise noted.

PARAMETER	SYMBOL	CONDITIONS	REF-10A			REF-10B			UNITS
			MIN	TYP	MAX	MIN	TYP	MAX	
Output Voltage	$V_O$	$I_L = 0$	9.97	10	10.03	9.95	10	10.05	V
Output Adjustment Range	$\Delta V_{trim}$	$R_P = 10k\Omega$	+3	$\pm 3.3$	—	$\pm 3$	$\pm 3.3$	—	%
Output Voltage Noise	$e_{np-p}$	0.1Hz to 10Hz (Note 5)	—	20	30	—	20	30	$\mu V_{p-p}$
Long-Term Stability		(Note 5)	—	—	50	—	—	50	ppm/1000 Hrs
Line Regulation (Note 4)		$V_{IN} = 13V$ to 33V	—	0.006	0.010	—	0.006	0.010	%/V
Load Regulation (Note 4)		$I_L = 0$ to 10mA	—	0.005	0.08	—	0.006	0.010	%/mA
Turn-On Settling Time	$t_{on}$	To $\pm 0.1\%$ of final value	—	5	—	—	5	—	$\mu sec.$
Quiescent Supply Current	$I_{SY}$	No Load	—	1.0	1.4	—	1.0	1.4	mA
Load Current	$I_L$		10	21	—	10	21	—	mA
Sink Current	$I_S$	(Note 6)	-0.3	-0.5	—	-0.3	-0.5	—	mA
Short-Circuit Current	$I_{SC}$	$V_O = 0$	15	30	60	15	30	60	mA

## ELECTRICAL CHARACTERISTICS at $V_{IN} = +15V$ , $-55^\circ C \leq T_A \leq +125^\circ C$ and $I_L = 0$ , unless otherwise noted.

PARAMETER	SYMBOL	CONDITIONS	REF-10A			REF-10B			UNITS
			MIN	TYP	MAX	MIN	TYP	MAX	
Output Voltage Change with Temperature (Notes 1 & 2)	$\Delta V_{OT}$	$-55^\circ C \leq T_A \leq +125^\circ C$	—	0.06	0.15	—	0.18	0.45	%
Output Voltage Temperature Coefficient	$TCV_O$	(Note 3)	—	3	8.5	—	10	25	ppm/°C
Change in $V_O$ Temperature Coefficient with Output Adjustment		$R_P = 10k\Omega$	—	0.7	—	—	0.7	—	ppm/%
Line Regulation ( $V_{IN} = 13V$ to 33V) (Note 4)		$-55^\circ C \leq T_A \leq +125^\circ C$	—	0.009	0.015	—	0.009	0.015	%/V
Load Regulation ( $I_L = 0$ to 8mA) (Note 4)		$-55^\circ C \leq T_A \leq +125^\circ C$	—	0.007	0.012	—	0.009	0.015	%/mA
Quiescent Supply Current	$I_{SY}$	No Load	—	1.6	2.0	—	1.6	2.0	mA

### NOTES:

- $\Delta V_{OT}$  is defined as the absolute difference between the maximum output voltage and the minimum output voltage over the specified temperature range expressed as a percentage of 10V.

$$\Delta V_{OT} = \left| \frac{V_{MAX} - V_{MIN}}{10V} \right| \times 100$$

- $\Delta V_{OT}$  specification applied trimmed to +10.000V or untrimmed.
- $TCV_O$  is defined as  $\Delta V_{OT}$  divided by the temperature range, i.e.,

$$TCV_O (-55^\circ C \text{ to } +125^\circ C) = \frac{\Delta V_{OT} (-55^\circ C \text{ to } +125^\circ C)}{180^\circ C}$$

- Line and Load Regulation specifications include the effect of self heating.
- Sample tested. Long-term stability is tested with power applied continuously.
- During sink current test the device meets the output voltage specified.

## OUTPUT ADJUSTMENT

The REF-10 trim terminal can be used to adjust the output voltage over a  $10V \pm 300mV$  range. This feature allows the system designer to trim system errors by setting the reference to a voltage other than 10V. Of course, the output can also be set to exactly 10.000V.

Adjustment of the output does not significantly affect the temperature performance of the device. Typically, the temperature coefficient change is  $0.7ppm/^{\circ}C$  per 100mV of output adjustment.

## OUTPUT ADJUSTMENT CIRCUIT

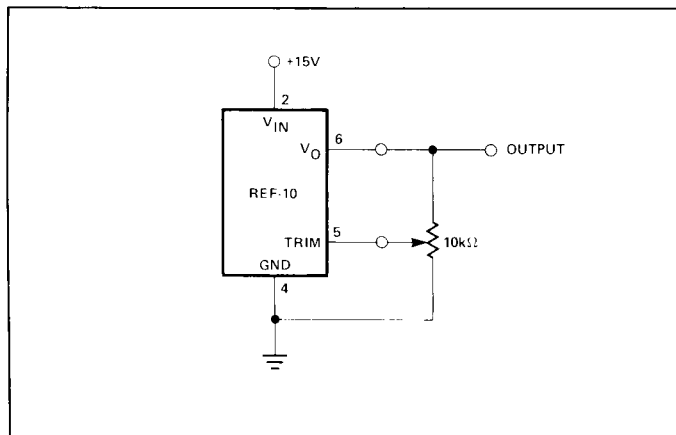

## BURN-IN CIRCUIT

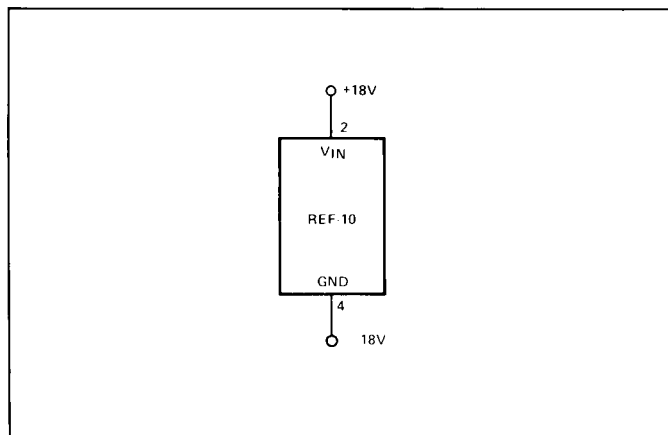

## TYPICAL PERFORMANCE CHARACTERISTICS

### LINE REGULATION vs FREQUENCY

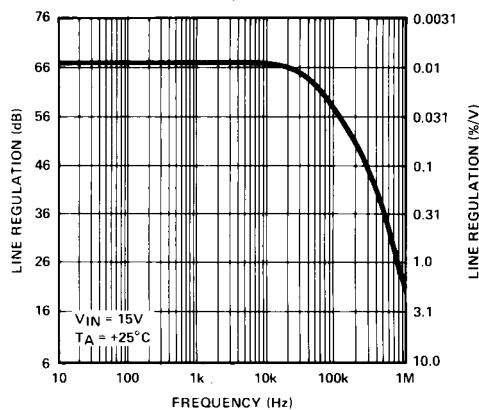

### OUTPUT WIDEBAND NOISE vs BANDWIDTH (0.1Hz TO FREQUENCY INDICATED)

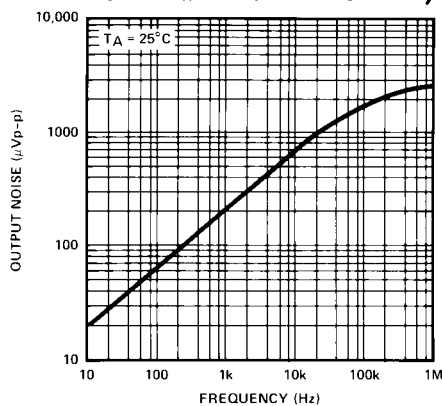

### OUTPUT CHANGE DUE TO THERMAL SHOCK

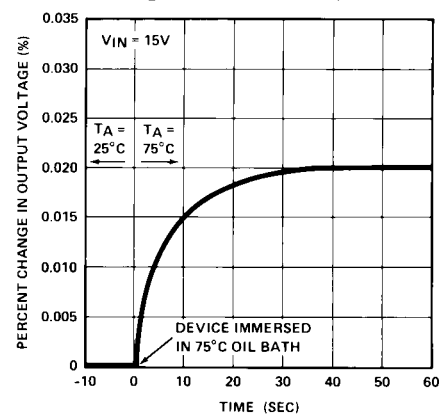

# REF-10

## TYPICAL PERFORMANCE CHARACTERISTICS

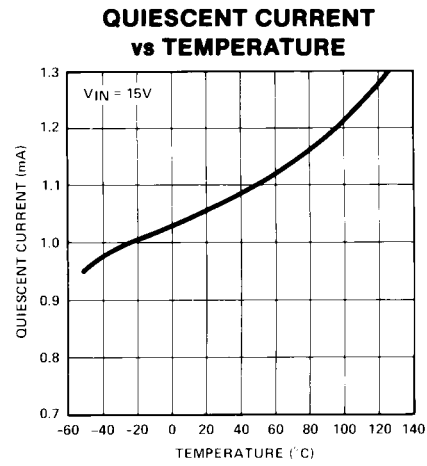
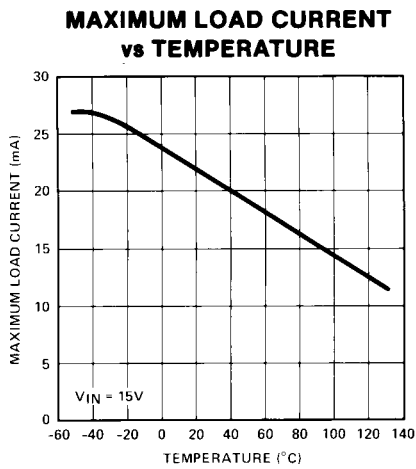
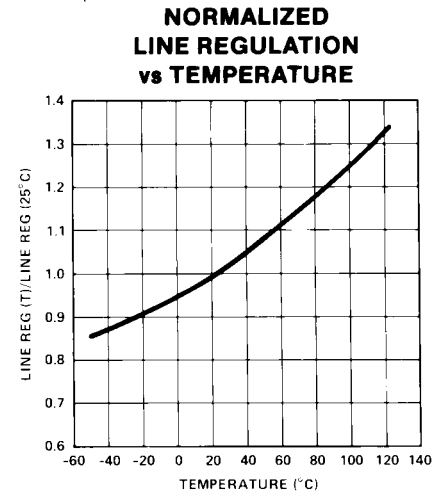
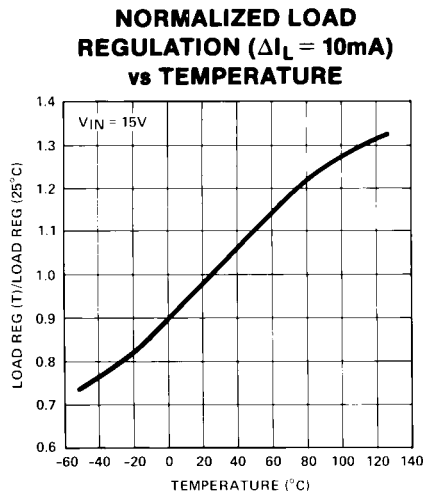
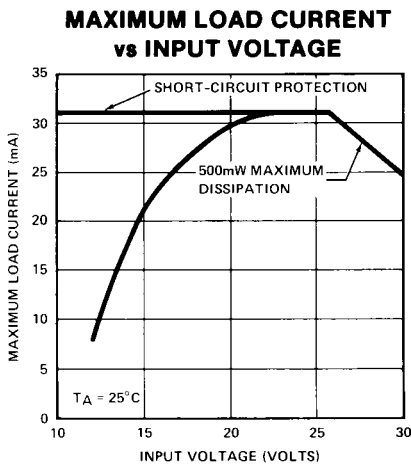

## TYPICAL APPLICATIONS

### D/A CONVERTER REFERENCE

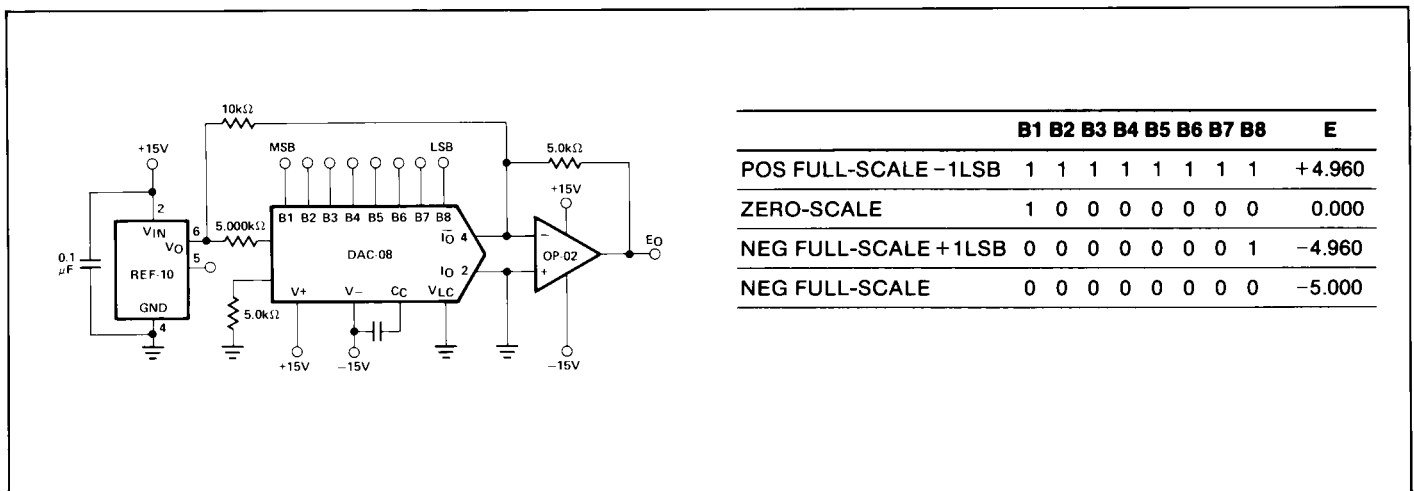

TYPICAL APPLICATIONS

PRECISION CALIBRATION STANDARD

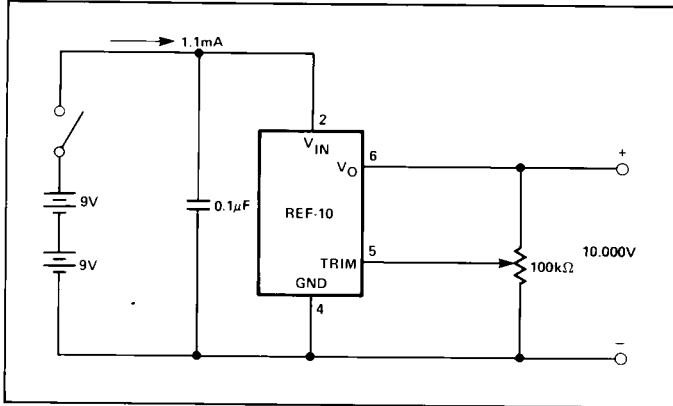

CURRENT SOURCE

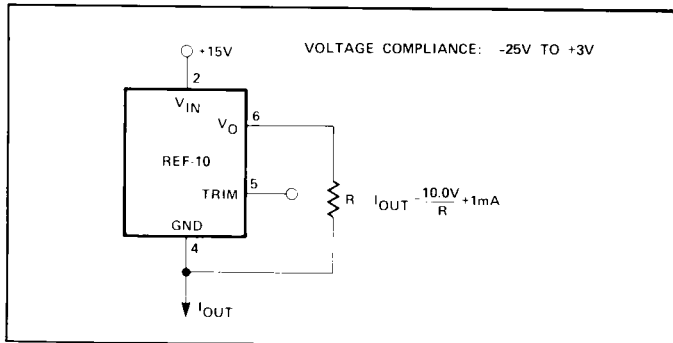

CURRENT SINK

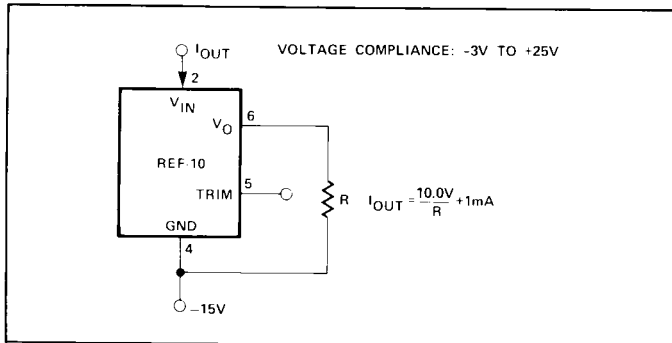

A/D CONVERTER REFERENCE

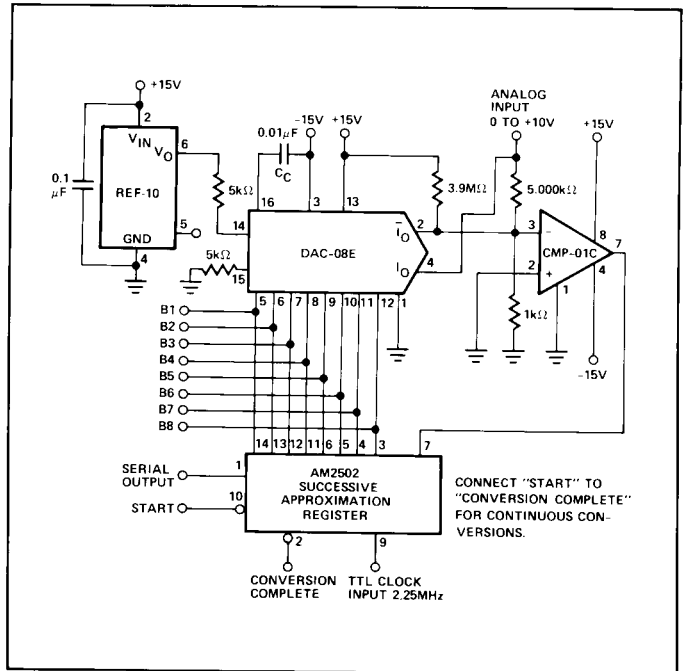

±10V REFERENCE

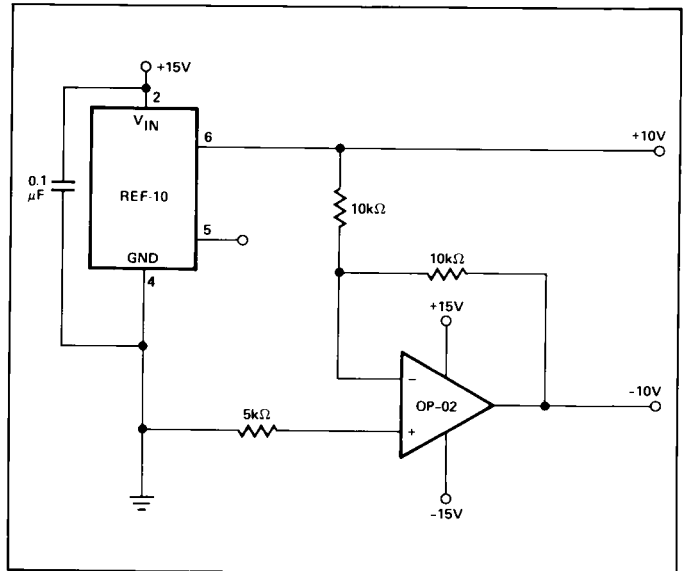

# REF-10

## PRECISION CURRENT SOURCE

A current source with 25V output compliance and excellent output impedance can be obtained using this circuit. REF-10 ② keeps the line voltage and power dissipation constant in device ①; the only important error consideration at room temperature is the negative supply rejection of the op amp. The typical  $3\mu\text{V/V}$  PSRR of the OP-02E will create an 8ppm change ( $3\mu\text{V/V} \times 25\text{V}/10\text{V}$ ) in output current over a 25V range. For example, a 10mA current source can be built ( $R = 1\text{k}\Omega$ ) with  $300\text{M}\Omega$  output impedance.

$$R_O = \frac{25\text{V}}{8 \times 10^{-6} \times 10\text{mA}}$$

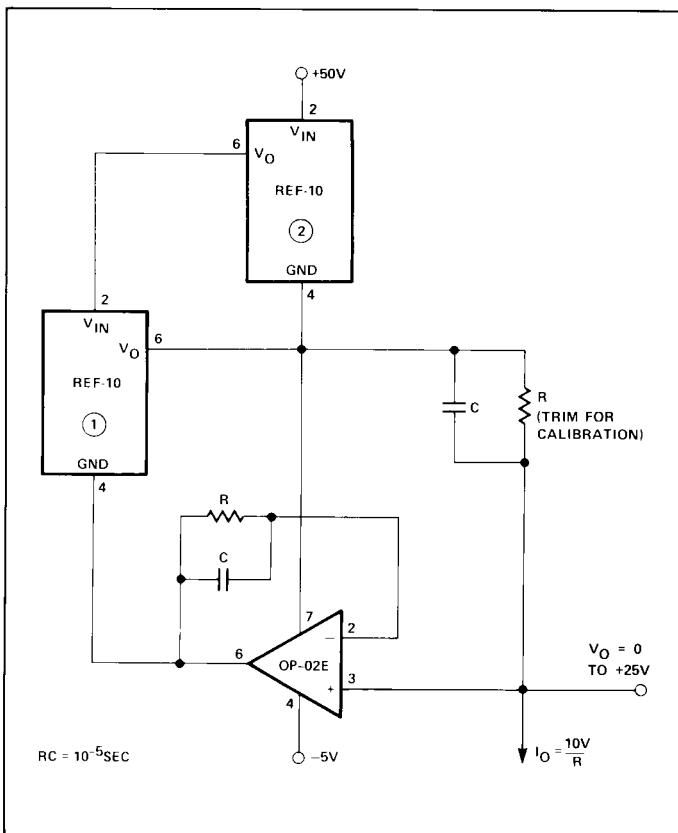

## REFERENCE STACK WITH EXCELLENT LINE REGULATION

Three REF-10's can be stacked to yield 10.000, 20.000 and 30.000V outputs. An additional advantage is near-perfect line regulation of the 10.000 and 20.000V output. A 32V to 60V input change produces an output change which is less than the noise voltage of the devices. A load bypass resistor ( $R_B$ ) provides a path for the supply current ( $I_{SY}$ ) of the 20.000V regulator.

In general, any number of REF-10's can be stacked this way. For example, ten devices will yield outputs of 10, 20, 30 . . . 100V. The line voltage can range from 105V to 130V. However, care must be taken to ensure that the total load currents do not exceed the maximum usable current (typically 21mA).

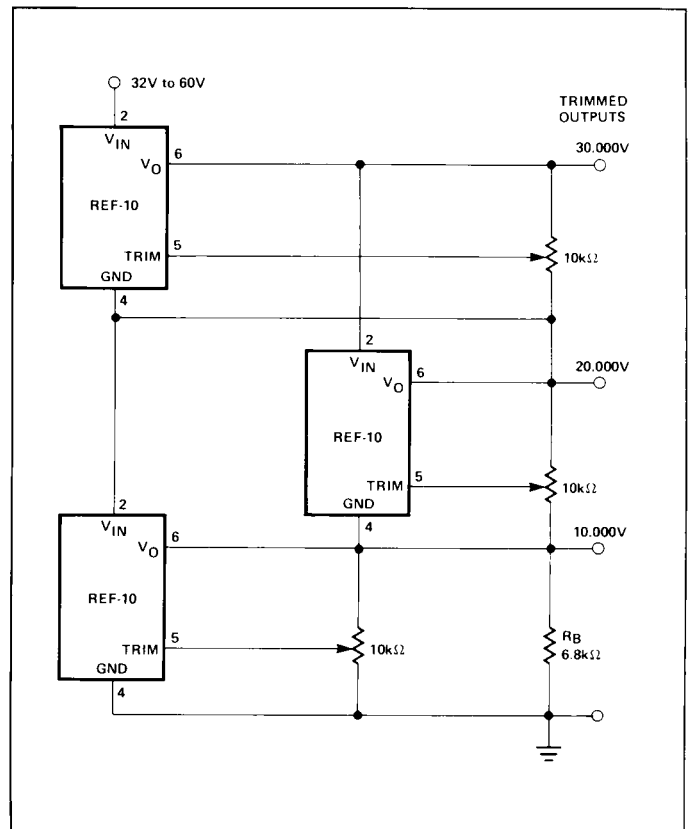

## SUPPLY BYPASSING

For best results, it is recommended that the power supply pin is bypassed with a  $0.1\mu\text{F}$  disc ceramic capacitor.