



STFI10NK60Z

N-channel 600 V, 0.65 Ω , 10 A, Zener-protected SuperMESH™ Power MOSFET in I²PAKFP package

Datasheet — production data

Features

Type	V _{DSS}	R _{DS(on) max}	I _D	P _{TOT}
STFI10NK60Z	600 V	< 0.75 Ω	10 A	35 W

- Fully insulated and low profile package with increased creepage path from pin to heatsink plate
- Extremely high dv/dt capability
- 100% avalanche tested
- Gate charge minimized

Applications

- Switching applications

Description

This device is an N-channel Zener-protected Power MOSFET developed using STMicroelectronics' SuperMESH™ technology, achieved through optimization of ST's well-established strip-based PowerMESH™ layout. In addition to a significant reduction in on-resistance, this device is designed to ensure a high level of dv/dt capability for the most demanding applications.

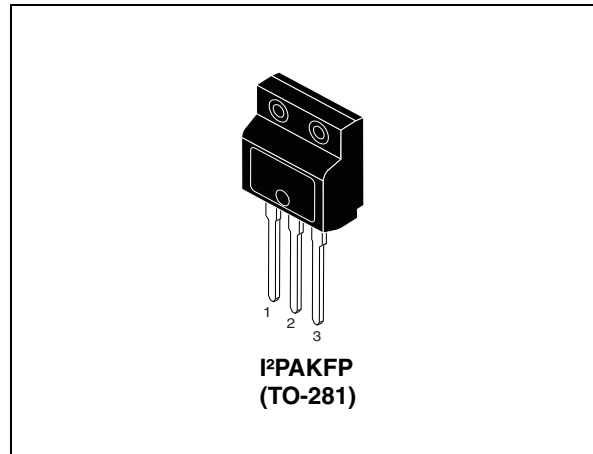

Figure 1. Internal schematic diagram

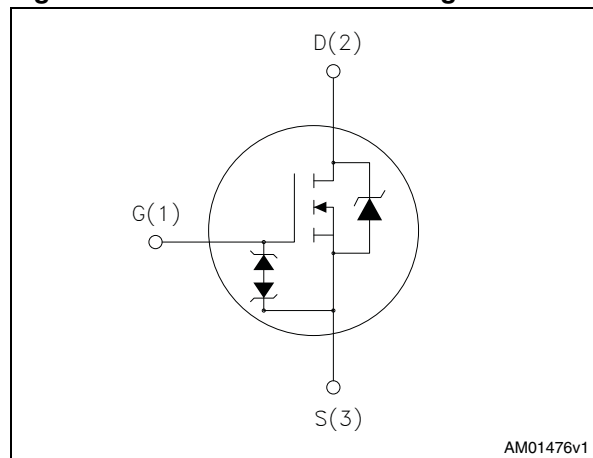

Table 1. Device summary

Order code	Marking	Package	Packaging
STFI10NK60Z	10NK60Z	I ² PAKFP (TO-281)	Tube

Contents

1	Electrical ratings	3
2	Electrical characteristics	4
2.1	Electrical characteristics (curves)	6
3	Test circuits	9
4	Package mechanical data	10
5	Revision history	12

1 Electrical ratings

Table 2. Absolute maximum ratings

Symbol	Parameter	Value	Unit
V_{DS}	Drain-source voltage	600	V
V_{GS}	Gate-source voltage	± 30	V
I_D	Drain current (continuous) at $T_C = 25\text{ }^\circ\text{C}$	10 ⁽¹⁾	A
I_D	Drain current (continuous) at $T_C = 100\text{ }^\circ\text{C}$	5.7 ⁽¹⁾	A
I_{DM} ⁽²⁾	Drain current (pulsed)	36 ⁽¹⁾	A
P_{TOT}	Total dissipation at $T_C = 25\text{ }^\circ\text{C}$	35	W
ESD	Gate-source human body model (R=1,5 k Ω C=100 pF)	4	kV
dv/dt ⁽³⁾	Peak diode recovery voltage slope	4.5	V/ns
V_{ISO}	Insulation withstand voltage (RMS) from all three leads to external heat sink (t=1 s; $T_C=25\text{ }^\circ\text{C}$)	2500	V
T_j T_{stg}	Operating junction temperature Storage temperature	-55 to 150	$^\circ\text{C}$

- Limited by maximum junction temperature
- Pulse width limited by safe operating area
- $I_{SD} < 10\text{A}$, $di/dt < 200\text{A}/\mu\text{s}$, $V_{DD} = 80\% V_{(BR)DSS}$

Table 3. Thermal data

Symbol	Parameter	Value	Unit
$R_{thj-case}$	Thermal resistance junction-case Max	3.6	$^\circ\text{C}/\text{W}$
$R_{thj-amb}$	Thermal resistance junction-amb Max	62.5	$^\circ\text{C}/\text{W}$

Table 4. Avalanche characteristics

Symbol	Parameter	Value	Unit
I_{AR}	Repetitive or non repetitive avalanche current	g ⁽¹⁾	A
E_{AS}	Single pulse avalanche energy (starting $T_j=25\text{ }^\circ\text{C}$, $I_D=I_{AR}$, $V_{DD}=50\text{ V}$)	300	mJ

- Limited by maximum junction temperature

2 Electrical characteristics

(T_{case} = 25 °C unless otherwise specified).

Table 5. On /off states

Symbol	Parameter	Test conditions	Min.	Typ.	Max.	Unit
V _{(BR)DSS}	Drain-source breakdown voltage, (V _{GS} = 0)	I _D = 250 μA	600			V
I _{DSS}	Zero gate voltage drain current (V _{GS} = 0)	V _{DS} = 600 V V _{DS} = 600 V, T _C = 125 °C			1 50	μA μA
I _{GSS}	Gate body leakage current (V _{DS} = 0)	V _{GS} = ±20 V			±10	μA
V _{GS(th)}	Gate threshold voltage	V _{DS} = V _{GS} , I _D = 250 μA	3	3.75	4.5	V
R _{DS(on)}	Static drain-source on resistance	V _{GS} = 10 V, I _D = 4.5 A		0.65	0.75	Ω

Table 6. Dynamic

Symbol	Parameter	Test conditions	Min.	Typ.	Max.	Unit
g _{fs} ⁽¹⁾	Forward transconductance	V _{DS} = 15 V, I _D = 4.5 A	-	7.8		S
C _{iss} C _{OSS} C _{rss}	Input capacitance Output capacitance Reverse transfer capacitance	V _{DS} = 25 V, f = 1 MHz, V _{GS} = 0	-	1370 156 37		pF pF pF
C _{OSS eq} ⁽²⁾	Equivalent output capacitance	V _{GS} = 0, V _{DS} = 0 to 480 V	-	90		pF
Q _g Q _{gs} Q _{gd}	Total gate charge Gate-source charge Gate-drain charge	V _{DD} = 480 V, I _D = 8 A V _{GS} = 10 V (see Figure 16)	-	50 10 25	70	nC nC nC

1. Pulsed: pulse duration = 300 μs, duty cycle 1.5%

2. C_{OSS eq} is defined as a constant equivalent capacitance giving the same charging time as C_{OSS} when V_{DS} increases from 0 to 80%

Table 7. Switching times

Symbol	Parameter	Test conditions	Min.	Typ.	Max	Unit
t _{d(on)} t _r	Turn-on delay time Rise time	V _{DD} = 300 V, I _D = 4 A, R _G = 4.7 Ω, V _{GS} = 10 V (see Figure 15)	-	20 20	-	ns ns
t _{d(off)} t _f	Turn-off delay time Fall time	V _{DD} = 300 V, I _D = 4 A, R _G = 4.7 Ω, V _{GS} = 10 V (see Figure 15)	-	55 30	-	ns ns

Table 8. Source drain diode

Symbol	Parameter	Test conditions	Min.	Typ.	Max.	Unit
I_{SD}	Source-drain current		-		10	A
$I_{SDM}^{(1)}$	Source-drain current (pulsed)		-		36	A
$V_{SD}^{(2)}$	Forward on voltage	$I_{SD}=10\text{ A}, V_{GS}=0$	-		1.6	V
t_{rr}	Reverse recovery time	$I_{SD}=8\text{ A}, di/dt = 100\text{ A}/\mu\text{s}, V_{DD}=40\text{ V}, T_j=150\text{ }^\circ\text{C}$	-	570		ns
Q_{rr}	Reverse recovery charge		-	4.3		μC
I_{RRM}	Reverse recovery current		-	15		A

1. Pulse width limited by safe operating area
2. Pulsed: pulse duration = 300 μs , duty cycle 1.5%

Table 9. Gate-source Zener diode

Symbol	Parameter	Test conditions	Min.	Typ.	Max.	Unit
$V_{(BR)GSO}$	Gate-source breakdown voltage ($I_D=0$)	$I_{GS} = \pm 1\text{ mA}$	30	-		V

The built-in back-to-back Zener diodes have specifically been designed to enhance not only the device's ESD capability, but also to make them safely absorb possible voltage transients that may occasionally be applied from gate to source. In this respect the Zener voltage is appropriate to achieve an efficient and cost-effective intervention to protect the device's integrity. These integrated Zener diodes thus avoid the usage of external components.

2.1 Electrical characteristics (curves)

Figure 2. Safe operating area

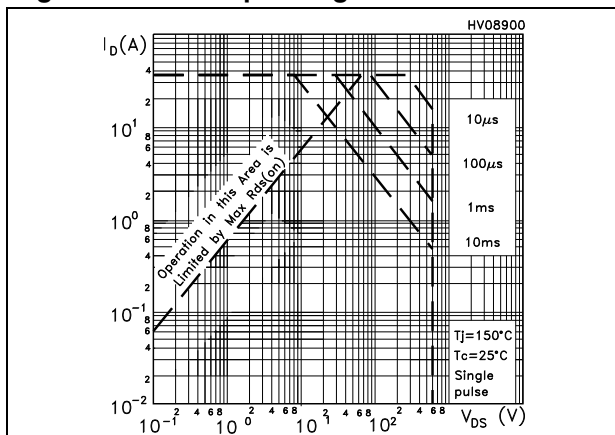

Figure 3. Thermal impedance

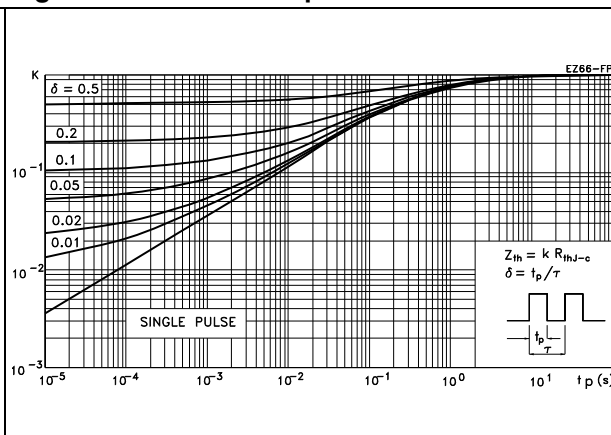

Figure 4. Output characteristics

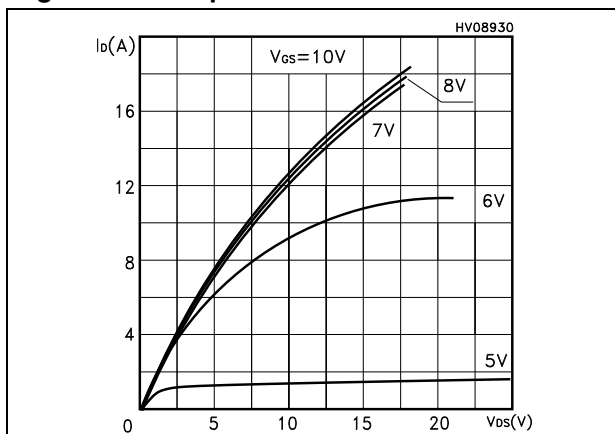

Figure 5. Transfer characteristics

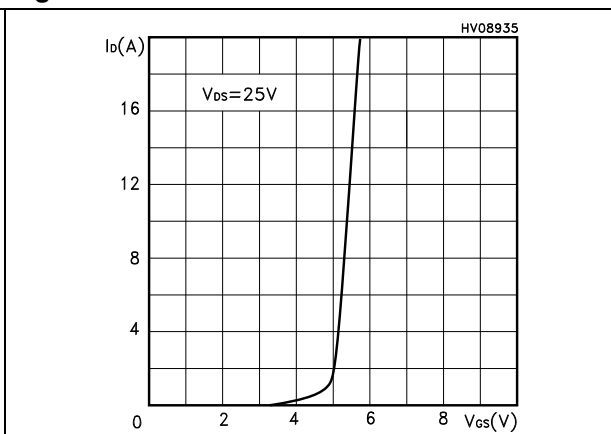

Figure 6. Transconductance

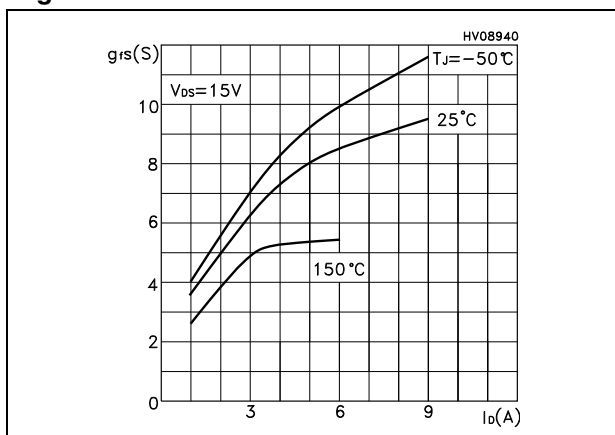

Figure 7. Static drain-source on resistance

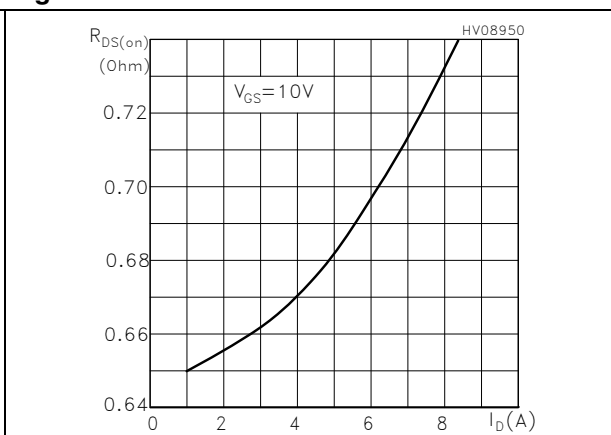

Figure 8. Gate charge vs gate-source voltage Figure 9. Capacitance variations

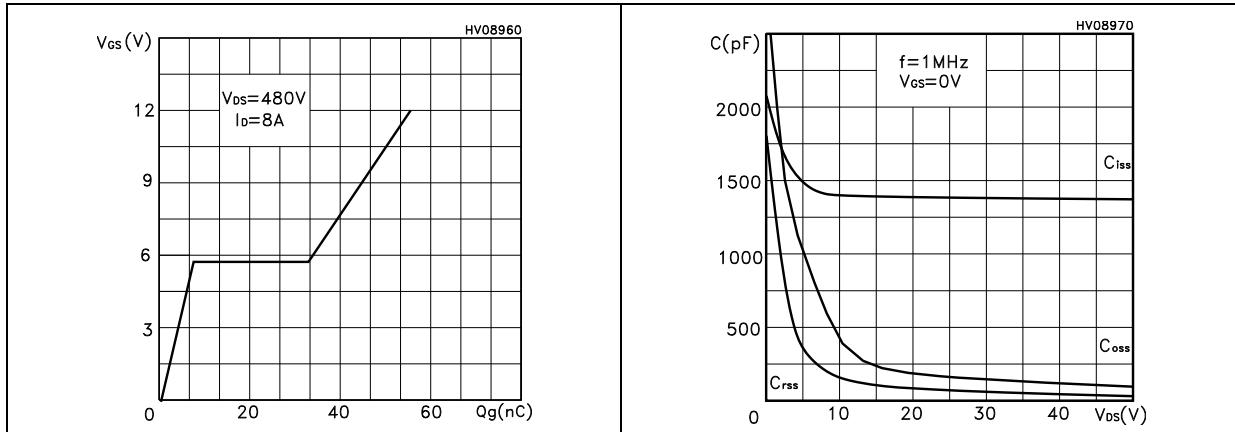

Figure 10. Normalized gate threshold voltage vs temperature Figure 11. Normalized on resistance vs temperature

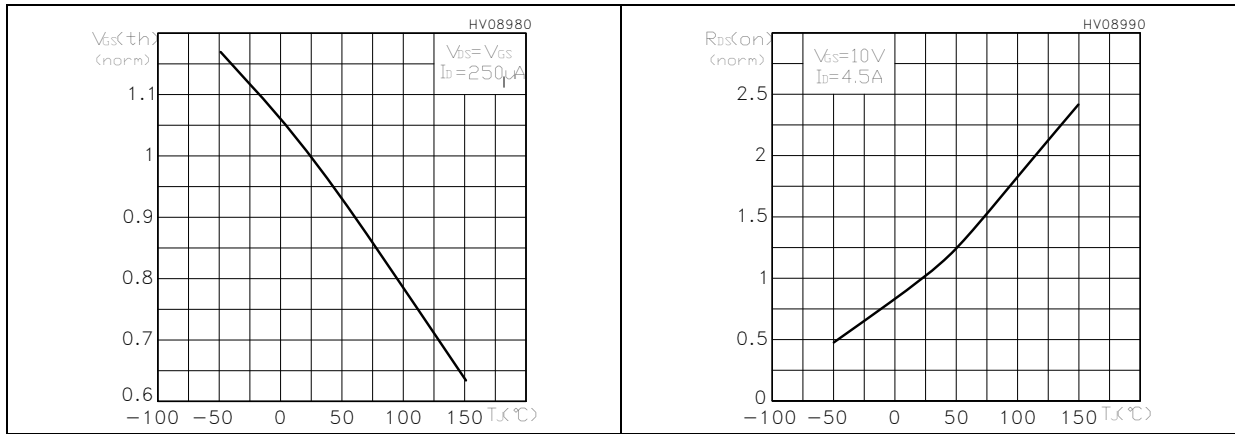

Figure 12. Source-drain diode forward characteristics Figure 13. Maximum avalanche energy vs temperature

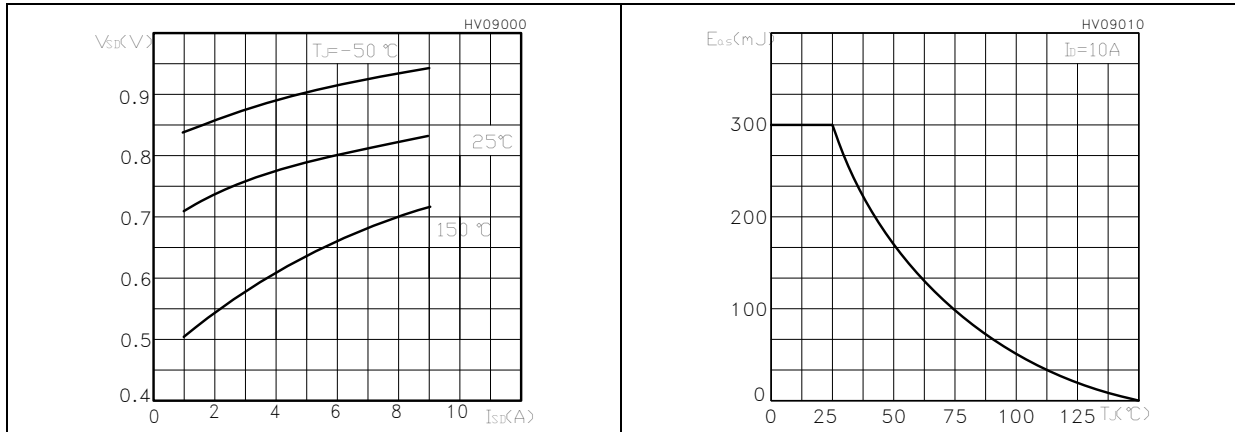
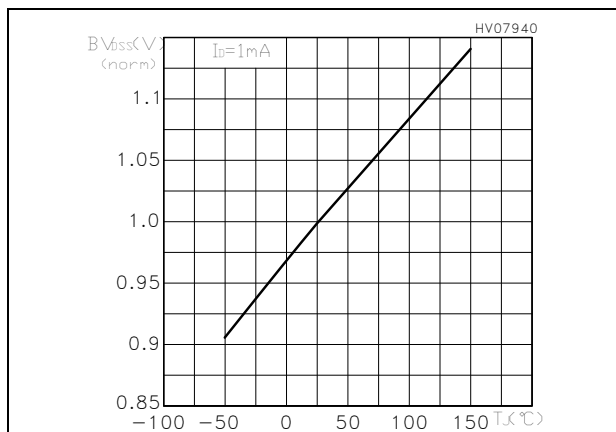
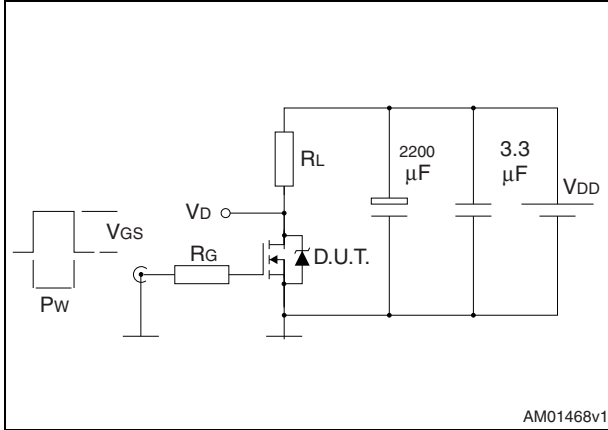

Figure 14. Normalized B_{VDSS} vs temperature



3 Test circuits

Figure 15. Switching times test circuit for resistive load



AM01468v1

Figure 16. Gate charge test circuit

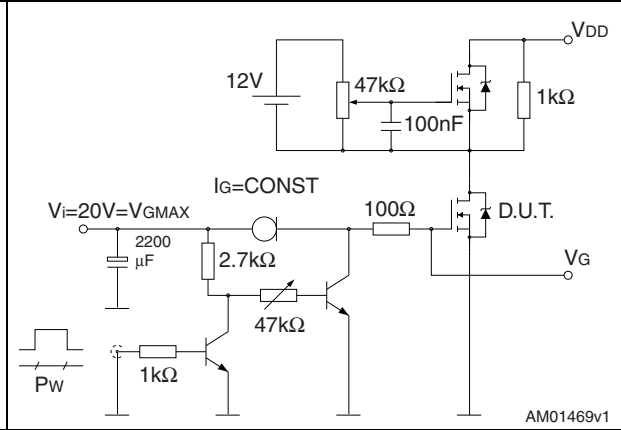

AM01469v1

Figure 17. Test circuit for inductive load switching and diode recovery times

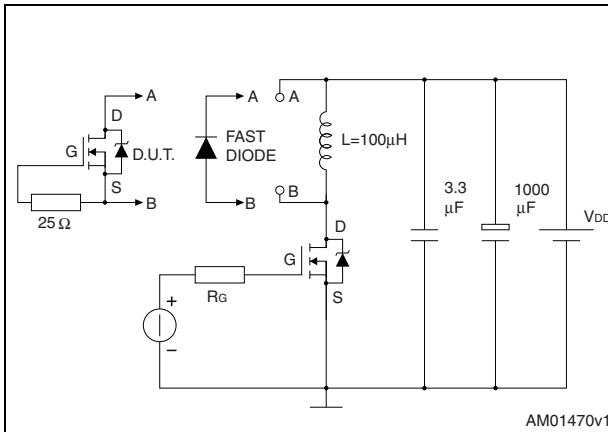

AM01470v1

Figure 18. Unclamped inductive load test circuit

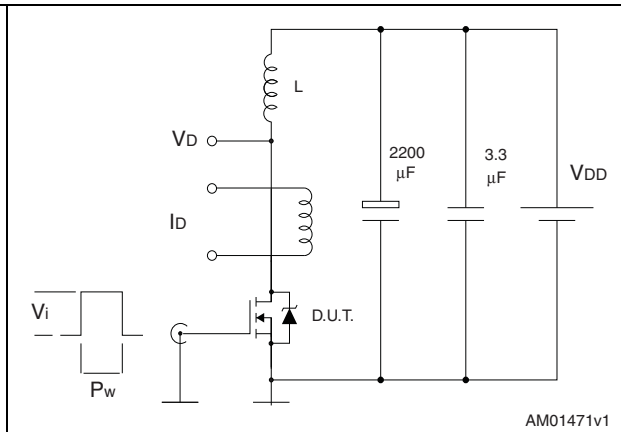

AM01471v1

Figure 19. Unclamped inductive waveform

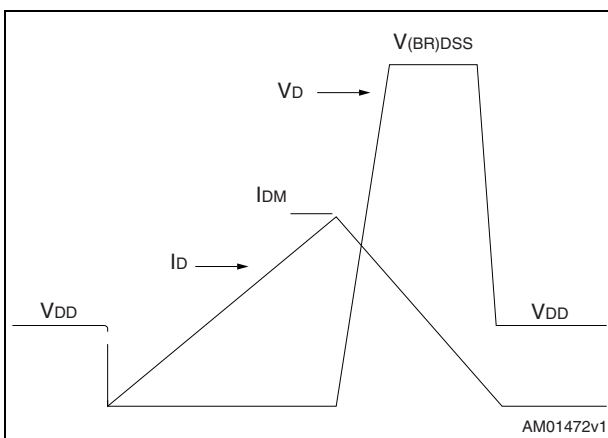

AM01472v1

Figure 20. Switching time waveform

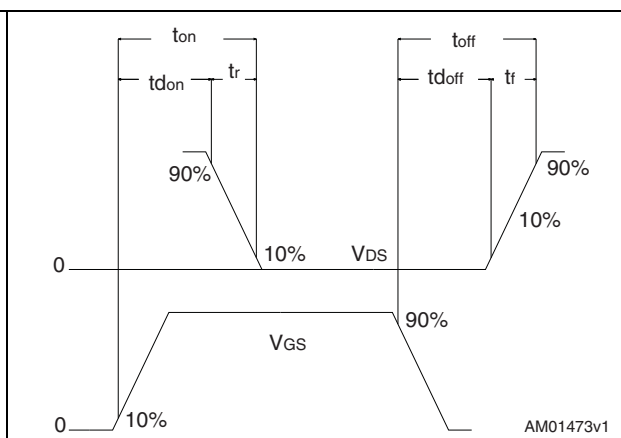

AM01473v1

4 Package mechanical data

In order to meet environmental requirements, ST offers these devices in different grades of ECOPACK® packages, depending on their level of environmental compliance. ECOPACK® specifications, grade definitions and product status are available at: www.st.com. ECOPACK is an ST trademark.

Table 10. I²PAKFP (TO-281) mechanical data

Dim.	mm		
	Min.	Typ.	Max.
A	4.40		4.60
B	2.50		2.70
D	2.50		2.75
D1	0.65		0.85
E	0.45		0.70
F	0.75		1.00
F1			1.20
G	4.95	-	5.20
H	10.00		10.40
L1	21.00		23.00
L2	13.20		14.10
L3	10.55		10.85
L4	2.70		3.20
L5	0.85		1.25
L6	7.30		7.50

Figure 21. I²PAKFP (TO-281) drawing

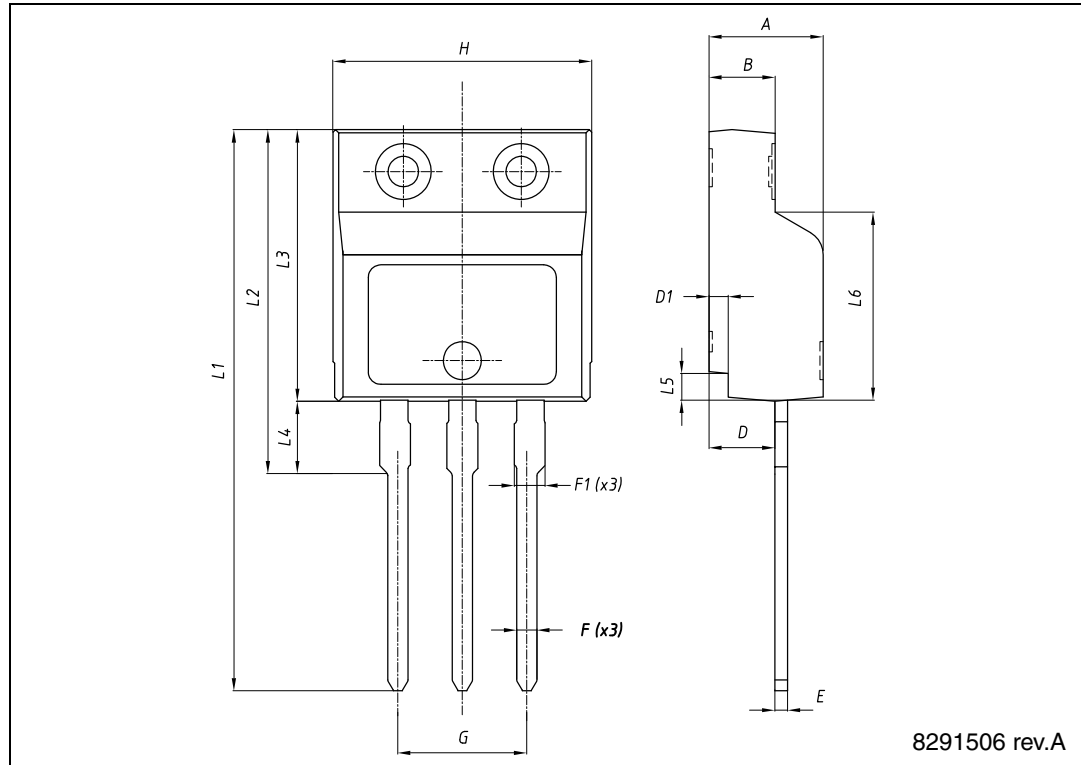

5 Revision history

Table 11. Document revision history

Date	Revision	Changes
27-Jun-2011	1	First release
03-Nov-2011	2	<i>Figure 2: Safe operating area</i> and <i>Figure 3: Thermal impedance</i> have been added.
19-Mar-2012	3	Document status promoted from preliminary data to production data. Package name has been updated.

Please Read Carefully:

Information in this document is provided solely in connection with ST products. STMicroelectronics NV and its subsidiaries ("ST") reserve the right to make changes, corrections, modifications or improvements, to this document, and the products and services described herein at any time, without notice.

All ST products are sold pursuant to ST's terms and conditions of sale.

Purchasers are solely responsible for the choice, selection and use of the ST products and services described herein, and ST assumes no liability whatsoever relating to the choice, selection or use of the ST products and services described herein.

No license, express or implied, by estoppel or otherwise, to any intellectual property rights is granted under this document. If any part of this document refers to any third party products or services it shall not be deemed a license grant by ST for the use of such third party products or services, or any intellectual property contained therein or considered as a warranty covering the use in any manner whatsoever of such third party products or services or any intellectual property contained therein.

UNLESS OTHERWISE SET FORTH IN ST'S TERMS AND CONDITIONS OF SALE ST DISCLAIMS ANY EXPRESS OR IMPLIED WARRANTY WITH RESPECT TO THE USE AND/OR SALE OF ST PRODUCTS INCLUDING WITHOUT LIMITATION IMPLIED WARRANTIES OF MERCHANTABILITY, FITNESS FOR A PARTICULAR PURPOSE (AND THEIR EQUIVALENTS UNDER THE LAWS OF ANY JURISDICTION), OR INFRINGEMENT OF ANY PATENT, COPYRIGHT OR OTHER INTELLECTUAL PROPERTY RIGHT.

UNLESS EXPRESSLY APPROVED IN WRITING BY TWO AUTHORIZED ST REPRESENTATIVES, ST PRODUCTS ARE NOT RECOMMENDED, AUTHORIZED OR WARRANTED FOR USE IN MILITARY, AIR CRAFT, SPACE, LIFE SAVING, OR LIFE SUSTAINING APPLICATIONS, NOR IN PRODUCTS OR SYSTEMS WHERE FAILURE OR MALFUNCTION MAY RESULT IN PERSONAL INJURY, DEATH, OR SEVERE PROPERTY OR ENVIRONMENTAL DAMAGE. ST PRODUCTS WHICH ARE NOT SPECIFIED AS "AUTOMOTIVE GRADE" MAY ONLY BE USED IN AUTOMOTIVE APPLICATIONS AT USER'S OWN RISK.

Resale of ST products with provisions different from the statements and/or technical features set forth in this document shall immediately void any warranty granted by ST for the ST product or service described herein and shall not create or extend in any manner whatsoever, any liability of ST.

ST and the ST logo are trademarks or registered trademarks of ST in various countries.

Information in this document supersedes and replaces all information previously supplied.

The ST logo is a registered trademark of STMicroelectronics. All other names are the property of their respective owners.

© 2012 STMicroelectronics - All rights reserved

STMicroelectronics group of companies

Australia - Belgium - Brazil - Canada - China - Czech Republic - Finland - France - Germany - Hong Kong - India - Israel - Italy - Japan - Malaysia - Malta - Morocco - Philippines - Singapore - Spain - Sweden - Switzerland - United Kingdom - United States of America

www.st.com

