



PCA8574/74A

Remote 8-bit I/O expander for I²C-bus with interrupt

Rev. 02 — 14 May 2007

Product data sheet

1. General description

The PCA8574/74A provide general purpose remote I/O expansion for most microcontroller families via the two-line bidirectional I²C-bus (serial clock (SCL), serial data (SDA)).

The devices consist of an 8-bit quasi-bidirectional port and an I²C-bus interface. The PCA8574/74A have low current consumption and include latched outputs with 25 mA high current drive capability for directly driving LEDs.

The PCA8574/74A also possess an interrupt line ($\overline{\text{INT}}$) that can be connected to the interrupt logic of the microcontroller. By sending an interrupt signal on this line, the remote I/O can inform the microcontroller if there is incoming data on its ports without having to communicate via the I²C-bus.

The internal Power-On Reset (POR) initializes the I/Os as inputs.

2. Features

- 400 kHz I²C-bus interface
- 2.3 V to 5.5 V operation with 5.5 V tolerant I/Os
- 8-bit remote I/O pins that default to inputs at power-up
- Latched outputs with 25 mA sink capability for directly driving LEDs
- Total package sink capability of 200 mA
- Active LOW open-drain interrupt output
- 8 programmable slave addresses using 3 address pins
- Readable device ID (manufacturer, device type, and revision)
- Low standby current (10 μ A max.)
- -40 °C to +85 °C operation
- ESD protection exceeds 2000 V HBM per JESD22-A114, 200 V MM per JESD22-A115, and 1000 V CDM per JESD22-C101
- Latch-up testing is done to JEDEC standard JESD78 which exceeds 100 mA
- Packages offered: DIP16, SO16, TSSOP16, SSOP20

3. Applications

- LED signs and displays
- Servers
- Industrial control
- Medical equipment
- PLCs

- Cellular telephones
- Gaming machines
- Instrumentation and test measurement

4. Ordering information

Table 1. Ordering information

Type number	Topside mark	Package		Version
		Name	Description	
PCA8574D	PCA8574D	SO16	plastic small outline package; 16 leads; body width 7.5 mm	SOT162-1
PCA8574AD	PCA8574AD			
PCA8574N	PCA8574N	DIP16	plastic dual in-line package; 16 leads (300 mil); long body	SOT38-1
PCA8574AN	PCA8574AN			
PCA8574PW	PCA8574	TSSOP16	plastic thin shrink small outline package; 16 leads; body width 4.4 mm	SOT403-1
PCA8574APW	PA8574A			
PCA8574TS	PCA8574	SSOP20	plastic shrink small outline package; 20 leads; body width 4.4 mm	SOT266-1
PCA8574ATS	PCA8574A			

5. Block diagram

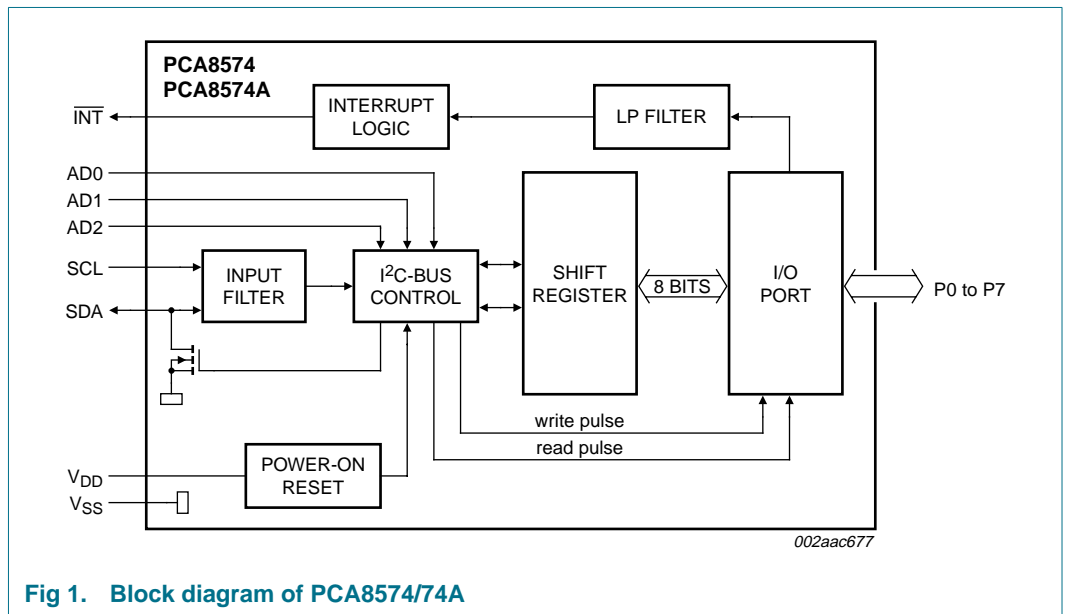

Fig 1. Block diagram of PCA8574/74A

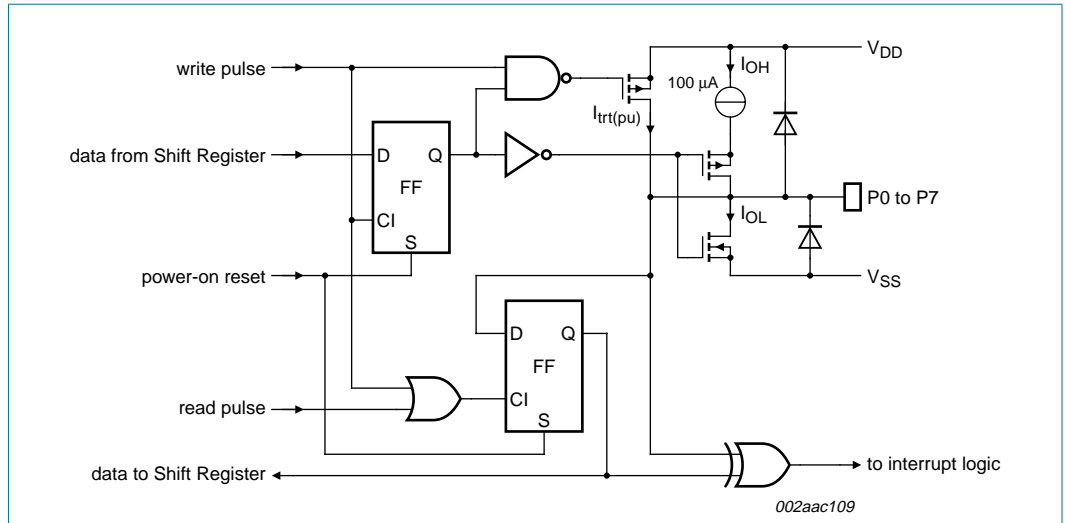

Fig 2. Simplified schematic diagram of P0 to P7

6. Pinning information

6.1 Pinning

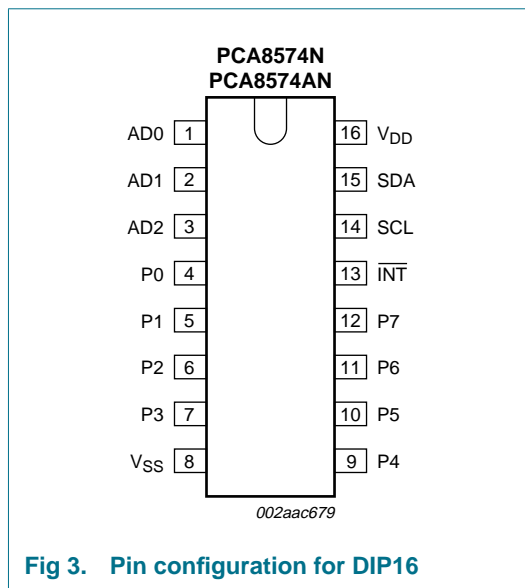

Fig 3. Pin configuration for DIP16

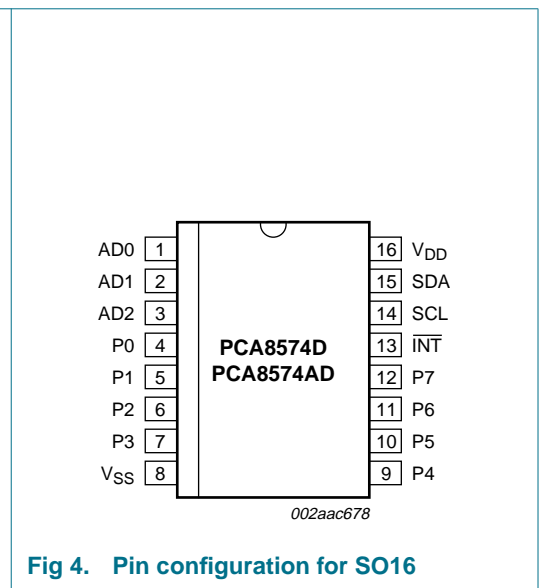

Fig 4. Pin configuration for SO16

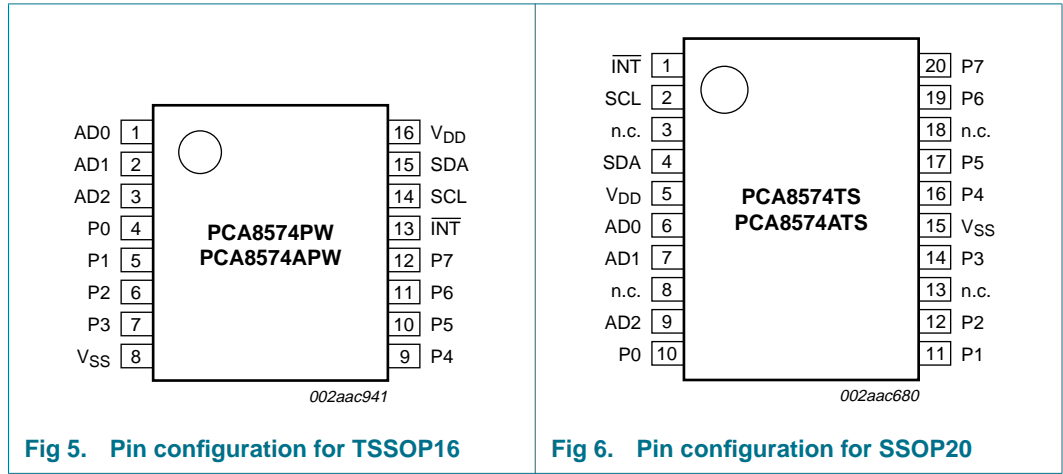

Fig 5. Pin configuration for TSSOP16

Fig 6. Pin configuration for SSOP20

6.2 Pin description

Table 2. Pin description for DIP16, SO16, TSSOP16

Symbol	Pin	Description
AD0	1	address input 0
AD1	2	address input 1
AD2	3	address input 2
P0	4	quasi-bidirectional I/O 0
P1	5	quasi-bidirectional I/O 1
P2	6	quasi-bidirectional I/O 2
P3	7	quasi-bidirectional I/O 3
V _{SS}	8	supply ground
P4	9	quasi-bidirectional I/O 4
P5	10	quasi-bidirectional I/O 5
P6	11	quasi-bidirectional I/O 6
P7	12	quasi-bidirectional I/O 7
$\overline{\text{INT}}$	13	interrupt output (active LOW)
SCL	14	serial clock line
SDA	15	serial data line
V _{DD}	16	supply voltage

Table 3. Pin description for SSOP20

Symbol	Pin	Description
INT	1	interrupt output (active LOW)
SCL	2	serial clock line
n.c.	3	not connected
SDA	4	serial data line
V _{DD}	5	supply voltage
AD0	6	address input 0
AD1	7	address input 1
n.c.	8	not connected
AD2	9	address input 2
P0	10	quasi-bidirectional I/O 0
P1	11	quasi-bidirectional I/O 1
P2	12	quasi-bidirectional I/O 2
n.c.	13	not connected
P3	14	quasi-bidirectional I/O 3
V _{SS}	15	supply ground
P4	16	quasi-bidirectional I/O 4
P5	17	quasi-bidirectional I/O 5
n.c.	18	not connected
P6	19	quasi-bidirectional I/O 6
P7	20	quasi-bidirectional I/O 7

7. Functional description

Refer to [Figure 1 “Block diagram of PCA8574/74A”](#).

7.1 Device address

Following a START condition, the bus master must send the address of the slave it is accessing and the operation it wants to perform (read or write). The address of the PCA8574/74A is shown in [Figure 7](#). Slave address pins AD2, AD1, and AD0 choose 1 of 8 slave addresses. To conserve power, no internal pull-up resistors are incorporated on AD2, AD1, and AD0. Address values depending on AD2, AD1, and AD0 can be found in [Table 4 “PCA8574 address map”](#) and [Table 5 “PCA8574A address map”](#).

Remark: When using the PCA8574A, the General Call address (0000 0000b) and the Device ID address (1111 100Xb) are reserved and cannot be used as device address. Failure to follow this requirement will cause the PCA8574A not to acknowledge.

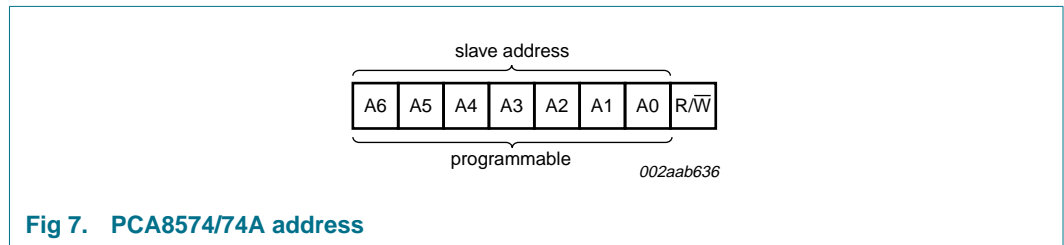

Fig 7. PCA8574/74A address

The last bit of the first byte defines the operation to be performed. When set to logic 1 a read is selected, while a logic 0 selects a write operation.

When AD2, AD1 and AD0 are held to V_{DD} or V_{SS}, the same address as the PCF8574 or PCF8574A is applied.

7.1.1 Address maps

Table 4. PCA8574 address map

A6	A5	A4	A3	A2	A1	A0	Address
0	1	0	0	0	0	0	20h
0	1	0	0	0	0	1	21h
0	1	0	0	0	1	0	22h
0	1	0	0	0	1	1	23h
0	1	0	0	1	0	0	24h
0	1	0	0	1	0	1	25h
0	1	0	0	1	1	0	26h
0	1	0	0	1	1	1	27h

Table 5. PCA8574A address map

A6	A5	A4	A3	A2	A1	A0	Address
0	1	1	1	0	0	0	38h
0	1	1	1	0	0	1	39h
0	1	1	1	0	1	0	3Ah
0	1	1	1	0	1	1	3Bh
0	1	1	1	1	0	0	3Ch
0	1	1	1	1	0	1	3Dh
0	1	1	1	1	1	0	3Eh
0	1	1	1	1	1	1	3Fh

8. I/O programming

8.1 Quasi-bidirectional I/O architecture

The PCA8574/74A's 8 ports (see [Figure 2](#)) are entirely independent and can be used either as input or output ports. Input data is transferred from the ports to the microcontroller in the Read mode (see [Figure 9](#)). Output data is transmitted to the ports in the Write mode (see [Figure 8](#)).

This quasi-bidirectional I/O can be used as an input or output without the use of a control signal for data directions. At power-on the I/Os are HIGH. In this mode only a current source (I_{OH}) to V_{DD} is active. An additional strong pull-up to V_{DD} ($I_{trt(pu)}$) allows fast rising edges into heavily loaded outputs. These devices turn on when an output is written HIGH, and are switched off by the negative edge of SCL. The I/Os should be HIGH before being used as inputs. After power-on, as all the I/Os are set HIGH, all of them can be used as inputs. Any change in setting of the I/Os as either inputs or outputs can be done with the write mode.

Remark: If a HIGH is applied to an I/O which has been written earlier to LOW, a large current (I_{OL}) will flow to V_{SS} .

8.2 Writing to the port (Output mode)

To write, the master (microcontroller) first addresses the slave device. By setting the last bit of the byte containing the slave address to logic 0 the write mode is entered. The PCA8574/74A acknowledges and the master sends the data byte for P7 to P0 and is acknowledged by the PCA8574/74A. The 8-bit data is presented on the port lines after it has been acknowledged by the PCA8574/74A.

The number of data bytes that can be sent successively is not limited. The previous data is overwritten every time a data byte has been sent.

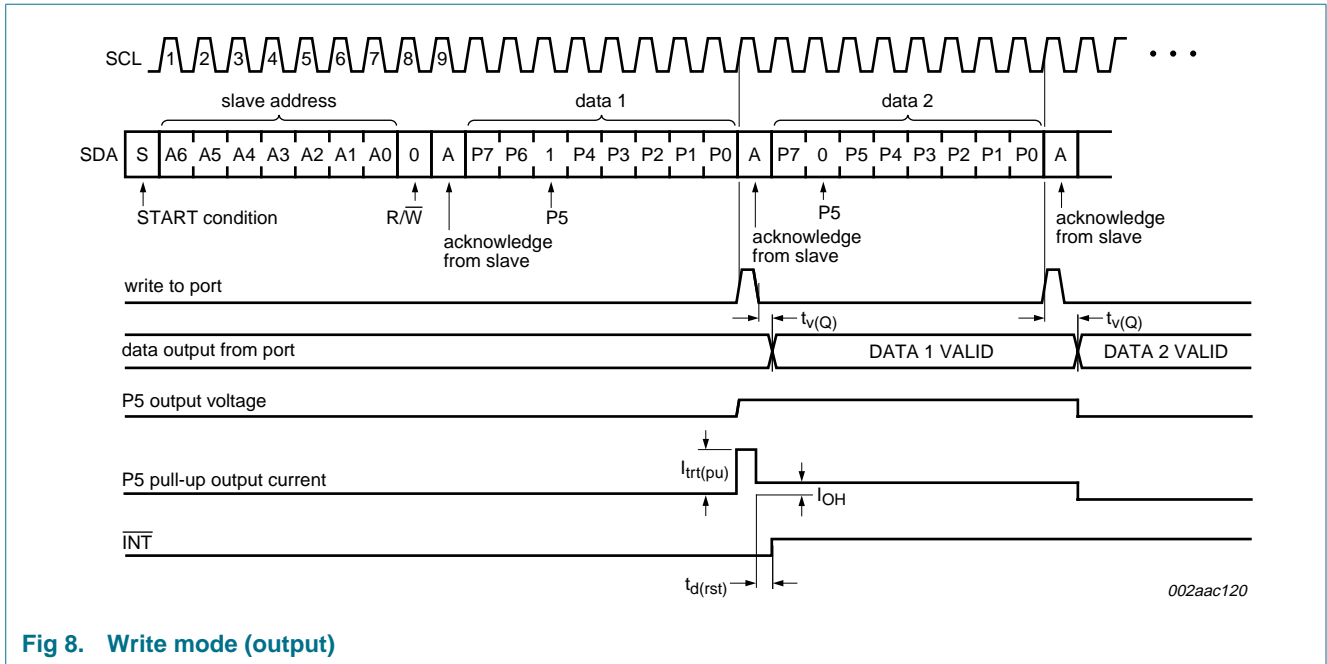
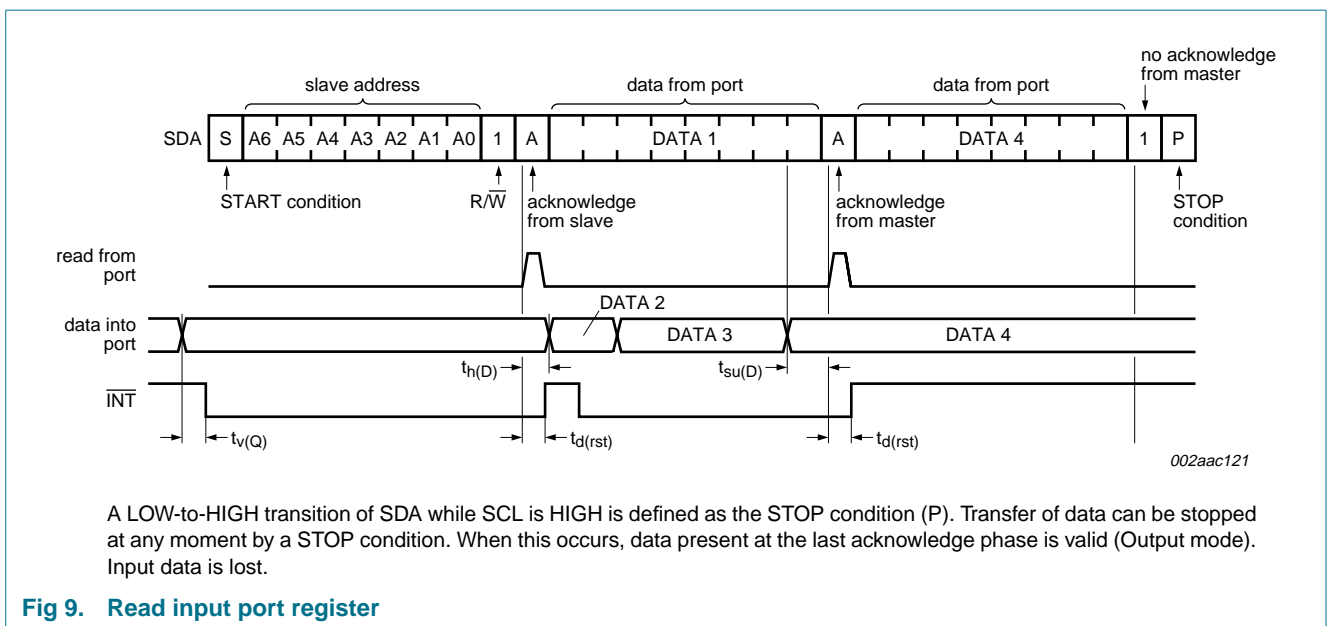

Fig 8. Write mode (output)

8.3 Reading from a port (Input mode)

All ports programmed as input should be set to logic 1. To read, the master (microcontroller) first addresses the slave device after it receives the interrupt. By setting the last bit of the byte containing the slave address to logic 1 the Read mode is entered. The data bytes that follow on the SDA are the values on the ports.

If the data on the input port changes faster than the master can read, this data may be lost.



A LOW-to-HIGH transition of SDA while SCL is HIGH is defined as the STOP condition (P). Transfer of data can be stopped at any moment by a STOP condition. When this occurs, data present at the last acknowledge phase is valid (Output mode). Input data is lost.

Fig 9. Read input port register

8.4 Power-on reset

When power is applied to V_{DD}, an internal Power-On Reset (POR) holds the PCA8574/74A in a reset condition until V_{DD} has reached V_{POR}. At that point, the reset condition is released and the PCA8574/74A registers and I²C-bus/SMBus state machine will initialize to their default states. Thereafter V_{DD} must be lowered below 0.2 V to reset the device.

8.5 Interrupt output ($\overline{\text{INT}}$)

The PCA8574/74A provides an open-drain interrupt ($\overline{\text{INT}}$) which can be fed to a corresponding input of the microcontroller (see [Figure 8](#), [Figure 9](#), and [Figure 10](#)). This gives these chips a kind of master function which can initiate an action elsewhere in the system.

An interrupt is generated by any rising or falling edge of the port inputs. After time t_{v(D)} the signal $\overline{\text{INT}}$ is valid.

The interrupt disappears when data on the port is changed to the original setting or data is read from or written to the device which has generated the interrupt.

In the write mode, the interrupt may become deactivated (HIGH) on the rising edge of the write to port pulse. On the falling edge of the write to port pulse the interrupt is definitely deactivated (HIGH).

The interrupt is reset in the read mode on the rising edge of the read from port pulse.

During the resetting of the interrupt itself, any changes on the I/Os may not generate an interrupt. After the interrupt is reset any change in I/Os will be detected and transmitted as an $\overline{\text{INT}}$.

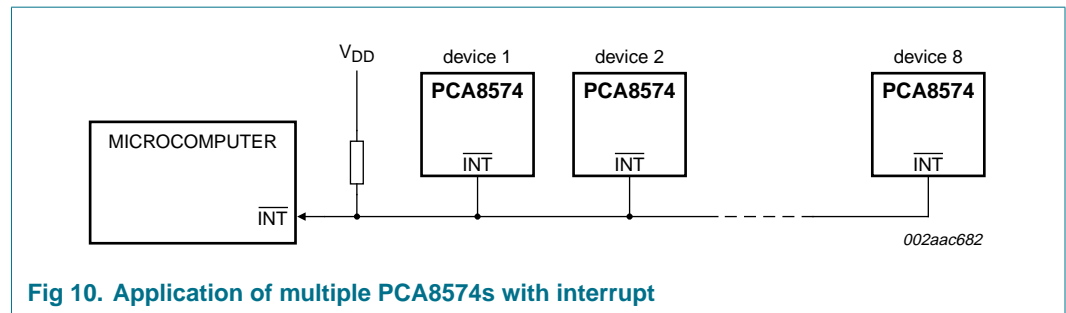

Fig 10. Application of multiple PCA8574s with interrupt

9. Characteristics of the I²C-bus

The I²C-bus is for 2-way, 2-line communication between different ICs or modules. The two lines are a serial data line (SDA) and a serial clock line (SCL). Both lines must be connected to a positive supply via a pull-up resistor when connected to the output stages of a device. Data transfer may be initiated only when the bus is not busy.

9.1 Bit transfer

One data bit is transferred during each clock pulse. The data on the SDA line must remain stable during the HIGH period of the clock pulse as changes in the data line at this time will be interpreted as control signals (see [Figure 11](#)).

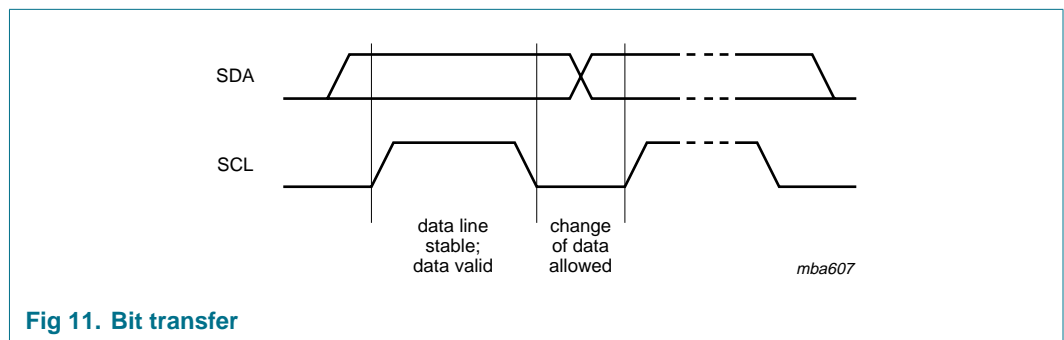

Fig 11. Bit transfer

9.1.1 START and STOP conditions

Both data and clock lines remain HIGH when the bus is not busy. A HIGH-to-LOW transition of the data line while the clock is HIGH is defined as the START condition (S). A LOW-to-HIGH transition of the data line while the clock is HIGH is defined as the STOP condition (P) (see [Figure 12](#).)

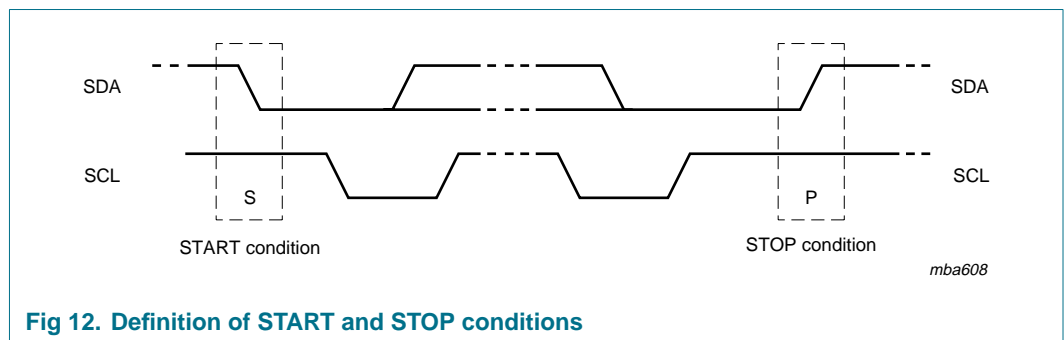
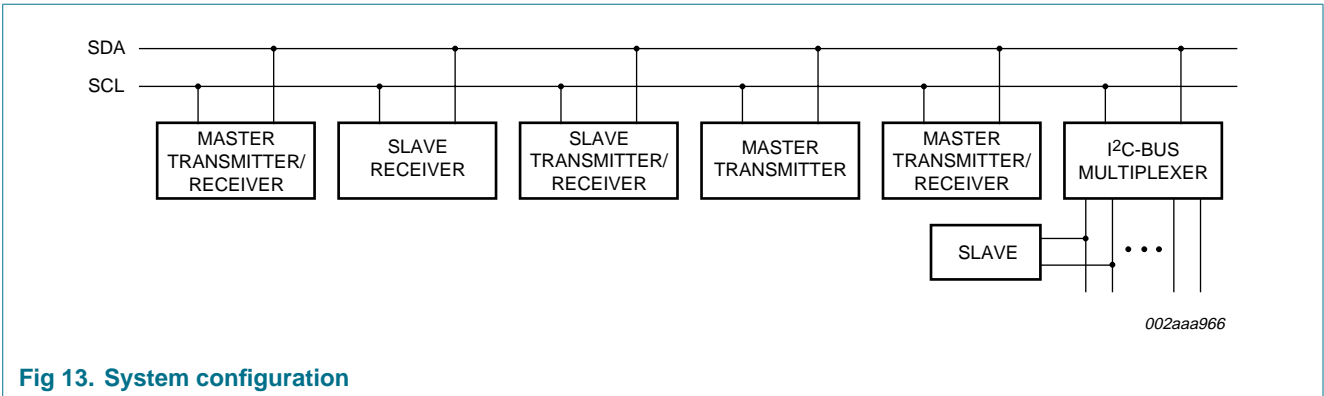

Fig 12. Definition of START and STOP conditions

9.2 System configuration

A device generating a message is a 'transmitter'; a device receiving is the 'receiver'. The device that controls the message is the 'master' and the devices which are controlled by the master are the 'slaves' (see [Figure 13](#)).



9.3 Acknowledge

The number of data bytes transferred between the START and the STOP conditions from transmitter to receiver is not limited. Each byte of eight bits is followed by one acknowledge bit. The acknowledge bit is a HIGH level put on the bus by the transmitter, whereas the master generates an extra acknowledge related clock pulse.

A slave receiver which is addressed must generate an acknowledge after the reception of each byte. Also a master must generate an acknowledge after the reception of each byte that has been clocked out of the slave transmitter. The device that acknowledges has to pull down the SDA line during the acknowledge clock pulse, so that the SDA line is stable LOW during the HIGH period of the acknowledge related clock pulse; set-up and hold times must be taken into account.

A master receiver must signal an end of data to the transmitter by not generating an acknowledge on the last byte that has been clocked out of the slave. In this event, the transmitter must leave the data line HIGH to enable the master to generate a STOP condition.

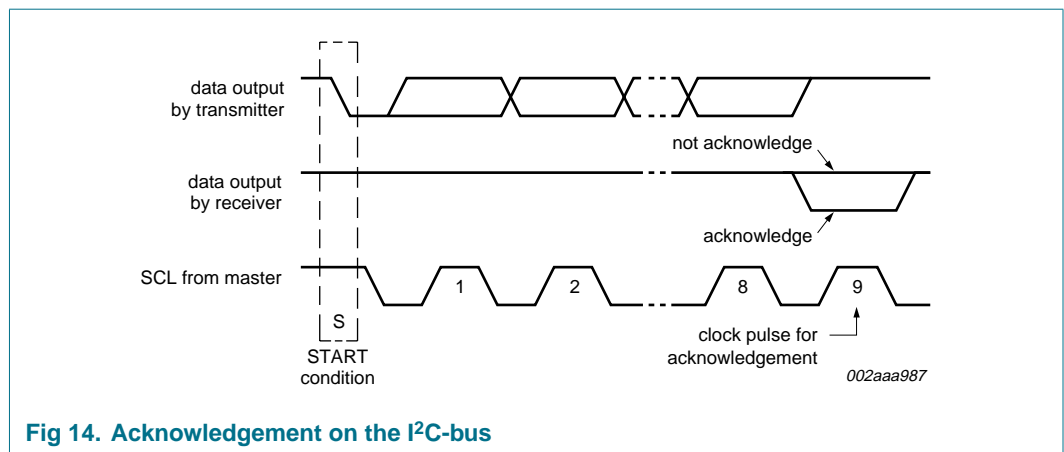

10. Application design-in information

10.1 Bidirectional I/O expander applications

In the 8-bit I/O expander application shown in [Figure 15](#), P0 and P1 are inputs, and P2 to P7 are outputs. When used in this configuration, during a write, the input (P0 and P1) must be written as HIGH so the external devices fully control the input ports. The desired HIGH or LOW logic levels may be written to the I/Os used as outputs (P2 to P7). During a read, the logic levels of the external devices driving the input ports (P0 and P1) and the previous written logic level to the output ports (P2 to P7) will be read.

The GPIO also has an interrupt line (\overline{INT}) that can be connected to the interrupt logic of the microprocessor. By sending an interrupt signal on this line, the remote I/O informs the microprocessor that there is incoming data or a change of data on its ports without having to communicate via the I²C-bus.

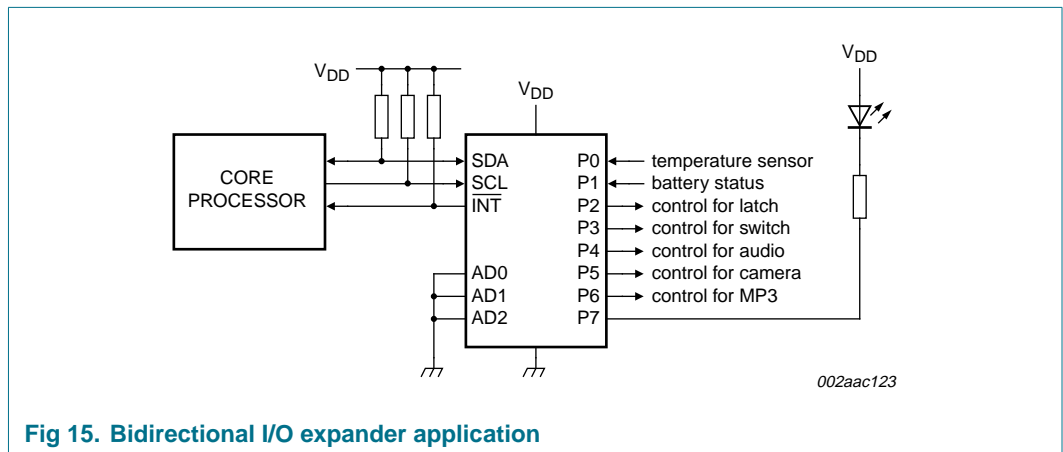

Fig 15. Bidirectional I/O expander application

10.2 High current-drive load applications

The GPIO has a maximum sinking current of 25 mA per bit. In applications requiring additional drive, two port pins in the same octal may be connected together to sink up to 50 mA current. Both bits must then always be turned on or off together. Up to 8 pins (one octal) can be connected together to drive 200 mA.

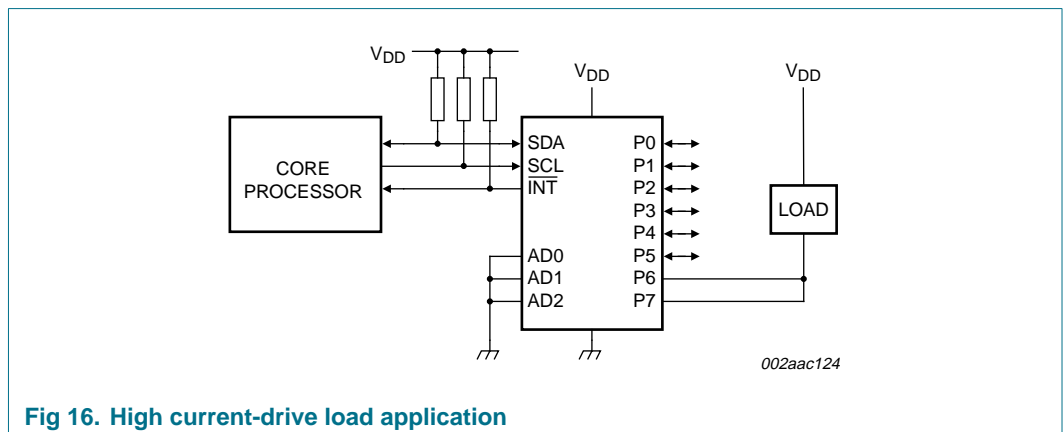

Fig 16. High current-drive load application

11. Limiting values

Table 6. Limiting values*In accordance with the Absolute Maximum Rating System (IEC 60134).*

Symbol	Parameter	Conditions	Min	Max	Unit
V _{DD}	supply voltage		-0.5	+6	V
I _{DD}	supply current		-	±100	mA
I _{SS}	ground supply current		-	±400	mA
V _I	input voltage		V _{SS} - 0.5	5.5	V
I _I	input current		-	±20	mA
I _O	output current	[1]	-	±50	mA
P _{tot}	total power dissipation		-	400	mW
P/out	power dissipation per output		-	100	mW
T _{stg}	storage temperature		-65	+150	°C
T _{amb}	ambient temperature	operating	-40	+85	°C

[1] Total package (maximum) output current is 400 mA.

12. Static characteristics

Table 7. Static characteristics

$V_{DD} = 2.3\text{ V to }5.5\text{ V}$; $V_{SS} = 0\text{ V}$; $T_{amb} = -40\text{ }^{\circ}\text{C to }+85\text{ }^{\circ}\text{C}$; unless otherwise specified.

Symbol	Parameter	Conditions	Min	Typ	Max	Unit
Supplies						
V_{DD}	supply voltage		2.3	-	5.5	V
I_{DD}	supply current	Operating mode; no load; $V_I = V_{DD}$ or V_{SS} ; $f_{SCL} = 400\text{ kHz}$; AD0, AD1, AD2 = static H or L	-	200	500	μA
I_{stb}	standby current	Standby mode; no load; $V_I = V_{DD}$ or V_{SS} ; $f_{SCL} = 0\text{ kHz}$	-	4.5	10	μA
V_{POR}	power-on reset voltage		[1] -	1.8	2.0	V
Input SCL; input/output SDA						
V_{IL}	LOW-level input voltage		-0.5	-	+0.3 V_{DD}	V
V_{IH}	HIGH-level input voltage		0.7 V_{DD}	-	5.5	V
I_{OL}	LOW-level output current	$V_{OL} = 0.4\text{ V}$; $V_{DD} = 2.3\text{ V}$	20	35	-	mA
		$V_{OL} = 0.4\text{ V}$; $V_{DD} = 3.0\text{ V}$	25	44	-	mA
		$V_{OL} = 0.4\text{ V}$; $V_{DD} = 4.5\text{ V}$	30	57	-	mA
I_L	leakage current	$V_I = V_{DD}$ or V_{SS}	-1	-	+1	μA
C_i	input capacitance	$V_I = V_{SS}$	-	5	10	pF
I/Os; P0 to P7						
I_{OL}	LOW-level output current	$V_{OL} = 0.5\text{ V}$; $V_{DD} = 2.3\text{ V}$	[2] 12	26	-	mA
		$V_{OL} = 0.5\text{ V}$; $V_{DD} = 3.0\text{ V}$	[2] 17	33	-	mA
		$V_{OL} = 0.5\text{ V}$; $V_{DD} = 4.5\text{ V}$	[2] 25	40	-	mA
$I_{OL(tot)}$	total LOW-level output current	$V_{OL} = 0.5\text{ V}$; $V_{DD} = 4.5\text{ V}$	[2] -	-	200	mA
I_{OH}	HIGH-level output current	$V_{OH} = V_{SS}$	-30	-138	-300	μA
$I_{trt(pu)}$	transient boosted pull-up current	$V_{OH} = V_{SS}$; see Figure 8	-0.5	-1.0	-	mA
C_i	input capacitance		[3] -	2.1	10	pF
C_o	output capacitance		[3] -	2.1	10	pF
Interrupt INT (see Figure 8 and Figure 9)						
I_{OL}	LOW-level output current	$V_{OL} = 0.4\text{ V}$	3.0	-	-	mA
C_o	output capacitance		-	3	5	pF
Inputs AD0, AD1, AD2						
V_{IL}	LOW-level input voltage		-0.5	-	+0.3 V_{DD}	V
V_{IH}	HIGH-level input voltage		0.7 V_{DD}	-	5.5	V
I_{LI}	input leakage current		-1	-	+1	μA
C_i	input capacitance		-	3.5	5	pF

[1] The power-on reset circuit resets the I²C-bus logic with $V_{DD} < V_{POR}$ and sets all I/Os to logic 1 (with current source to V_{DD}).

[2] Each bit must be limited to a maximum of 25 mA and the total package limited to 200 mA due to internal busing limits.

[3] The value is not tested, but verified on sampling basis.

13. Dynamic characteristics

Table 8. Dynamic characteristics

$V_{DD} = 2.3\text{ V to }5.5\text{ V}$; $V_{SS} = 0\text{ V}$; $T_{amb} = -40\text{ }^{\circ}\text{C to }+85\text{ }^{\circ}\text{C}$; unless otherwise specified. Limits are for Fast-mode I²C-bus.

Symbol	Parameter	Conditions	Min	Typ	Max	Unit
f _{SCL}	SCL clock frequency		0	-	400	kHz
t _{BUF}	bus free time between a STOP and START condition		1.3	-	-	μs
t _{HD,STA}	hold time (repeated) START condition		0.6	-	-	μs
t _{SU,STA}	set-up time for a repeated START condition		0.6	-	-	μs
t _{SU,STO}	set-up time for STOP condition		0.6	-	-	μs
t _{HD,DAT}	data hold time		0	-	-	ns
t _{VD,ACK}	data valid acknowledge time ^[1]		0.1	-	0.9	μs
t _{VD,DAT}	data valid time ^[2]		50	-	-	ns
t _{SU,DAT}	data set-up time		100	-	-	ns
t _{LOW}	LOW period of the SCL clock		1.3	-	-	μs
t _{HIGH}	HIGH period of the SCL clock		0.6	-	-	μs
t _f	fall time of both SDA and SCL signals	^{[3][4]}	20 + 0.1C _b ^[5]	-	300	ns
t _r	rise time of both SDA and SCL signals		20 + 0.1C _b ^[5]	-	300	ns
t _{SP}	pulse width of spikes that must be suppressed by the input filter ^[6]		-	-	50	ns

Port timing; C_L ≤ 100 pF (see Figure 8 and Figure 9)

t _{V(Q)}	data output valid time		-	-	4	μs
t _{SU(D)}	data input set-up time		0	-	-	μs
t _{H(D)}	data input hold time		4	-	-	μs

Interrupt timing; C_L ≤ 100 pF (see Figure 8 and Figure 9)

t _{V(D)}	data input valid time		-	-	4	μs
t _{d(rst)}	reset delay time		-	-	4	μs

[1] t_{VD,ACK} = time for Acknowledgement signal from SCL LOW to SDA (out) LOW.

[2] t_{VD,DAT} = minimum time for SDA data out to be valid following SCL LOW.

[3] A master device must internally provide a hold time of at least 300 ns for the SDA signal (refer to the V_{IL} of the SCL signal) in order to bridge the undefined region SCL's falling edge.

[4] The maximum t_r for the SDA and SCL bus lines is specified at 300 ns. The maximum fall time for the SDA output stage t_f is specified at 250 ns. This allows series protection resistors to be connected between the SDA and the SCL pins and the SDA/SCL bus lines without exceeding the maximum specified t_r.

[5] C_b = total capacitance of one bus line in pF.

[6] Input filters on the SDA and SCL inputs suppress noise spikes less than 50 ns.

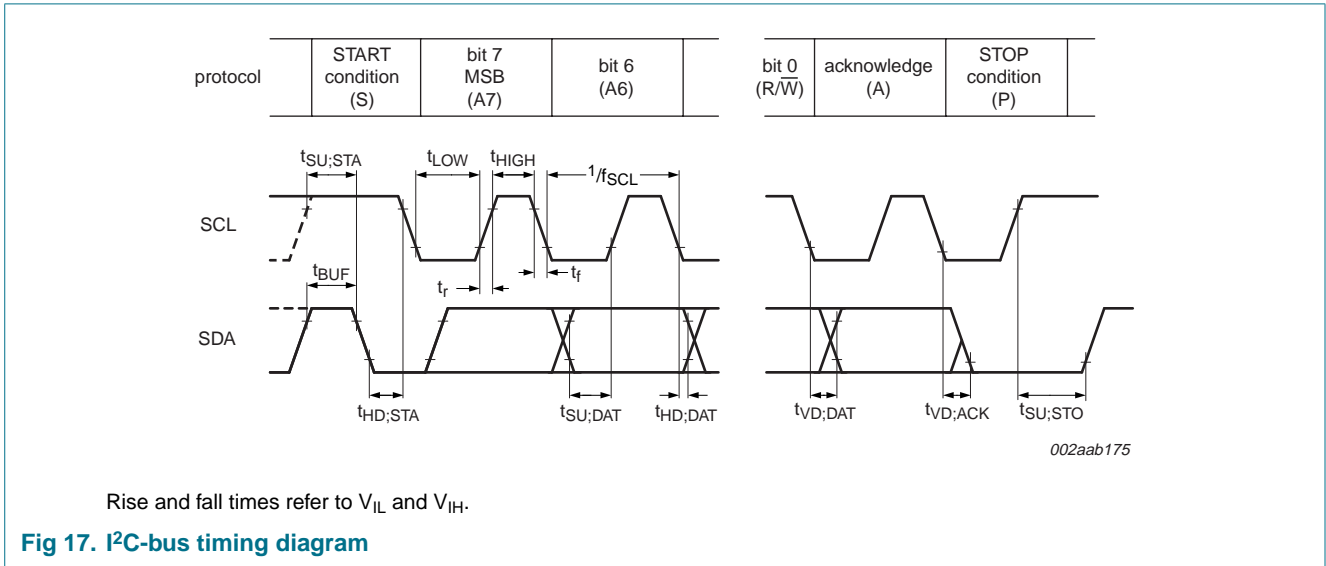

Fig 17. I²C-bus timing diagram

14. Package outline

DIP16: plastic dual in-line package; 16 leads (300 mil); long body

SOT38-1

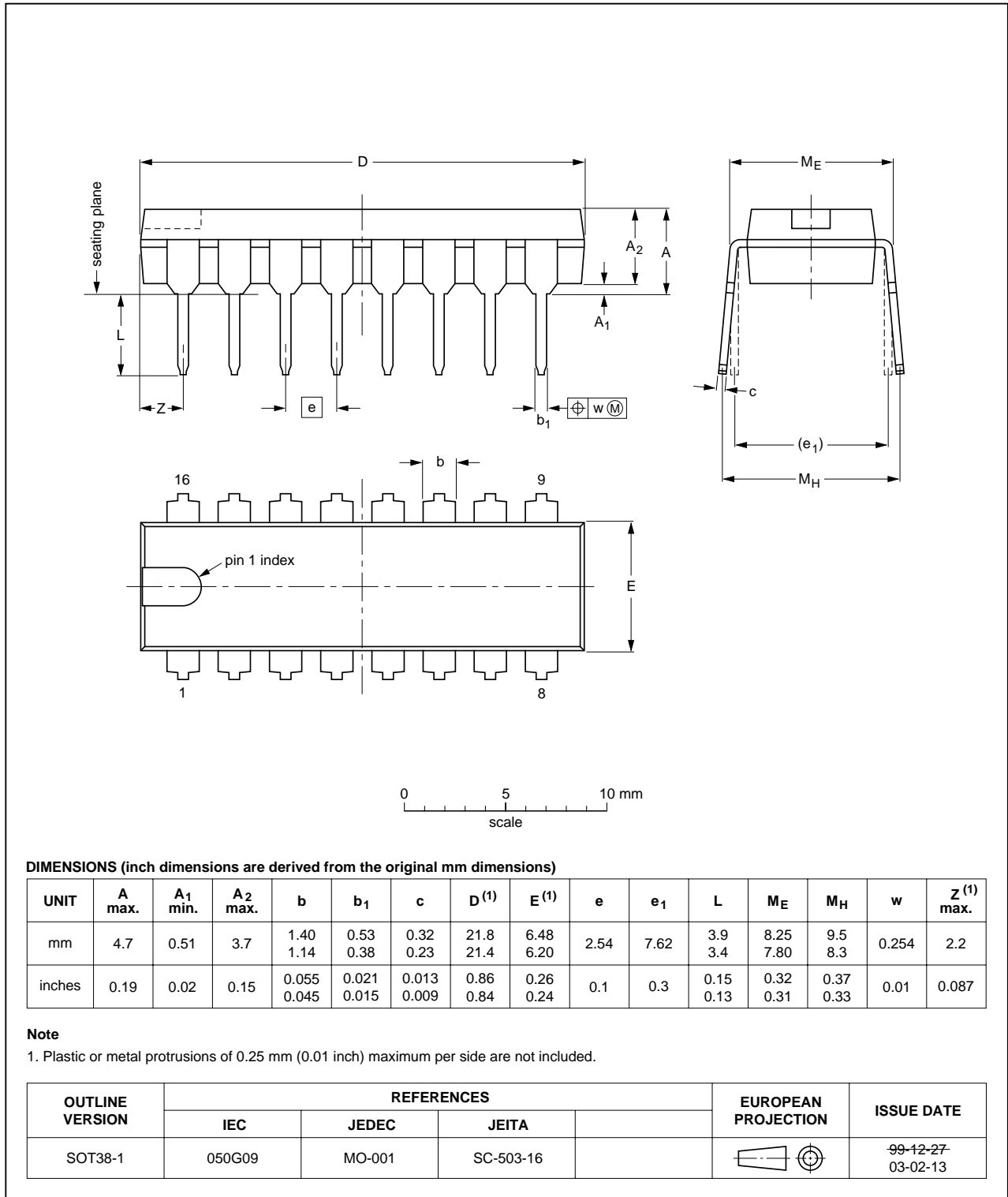

Fig 18. Package outline SOT38-1 (DIP16)

SO16: plastic small outline package; 16 leads; body width 7.5 mm

SOT162-1

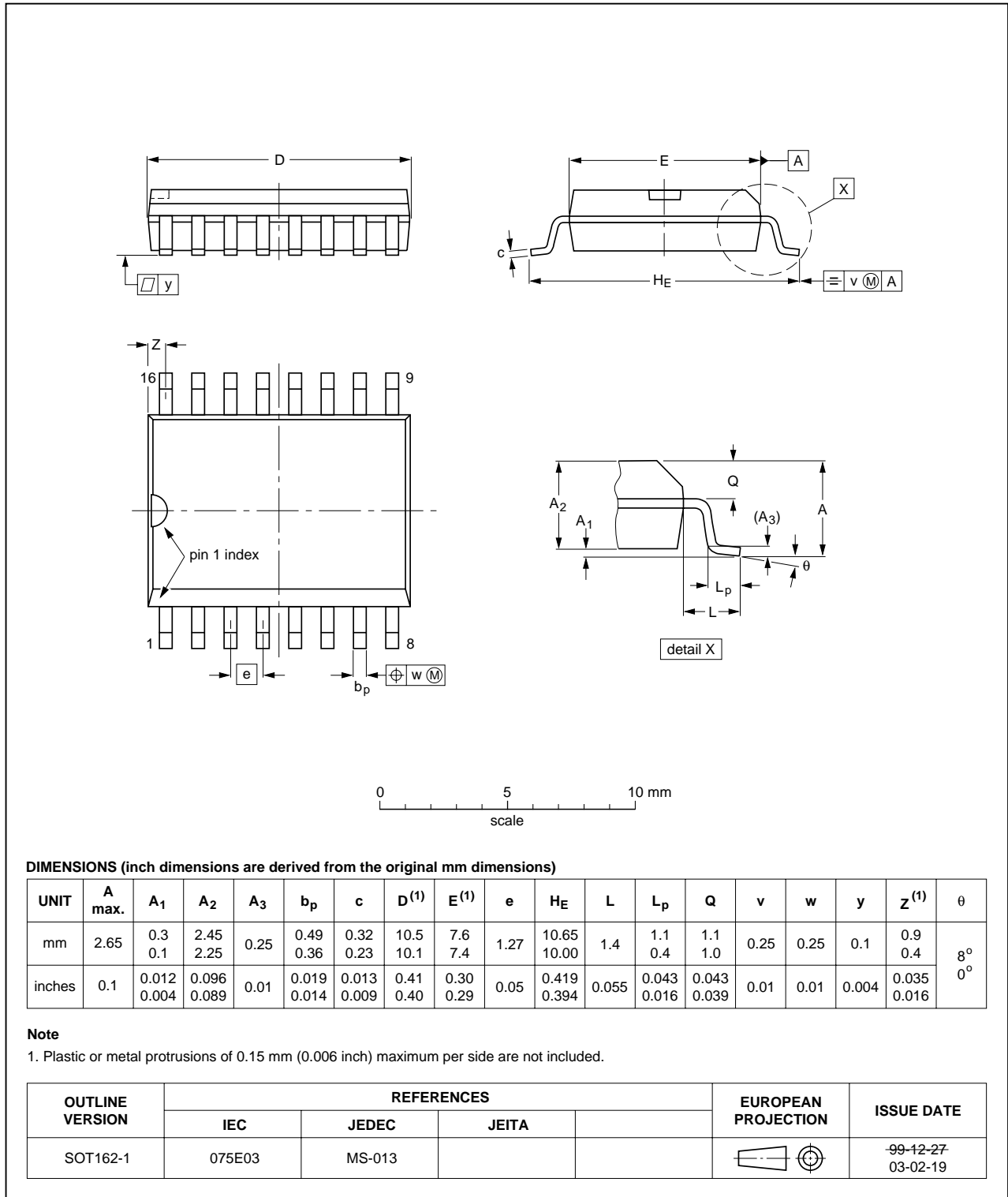

Fig 19. Package outline SOT162-1 (SO16)

TSSOP16: plastic thin shrink small outline package; 16 leads; body width 4.4 mm

SOT403-1

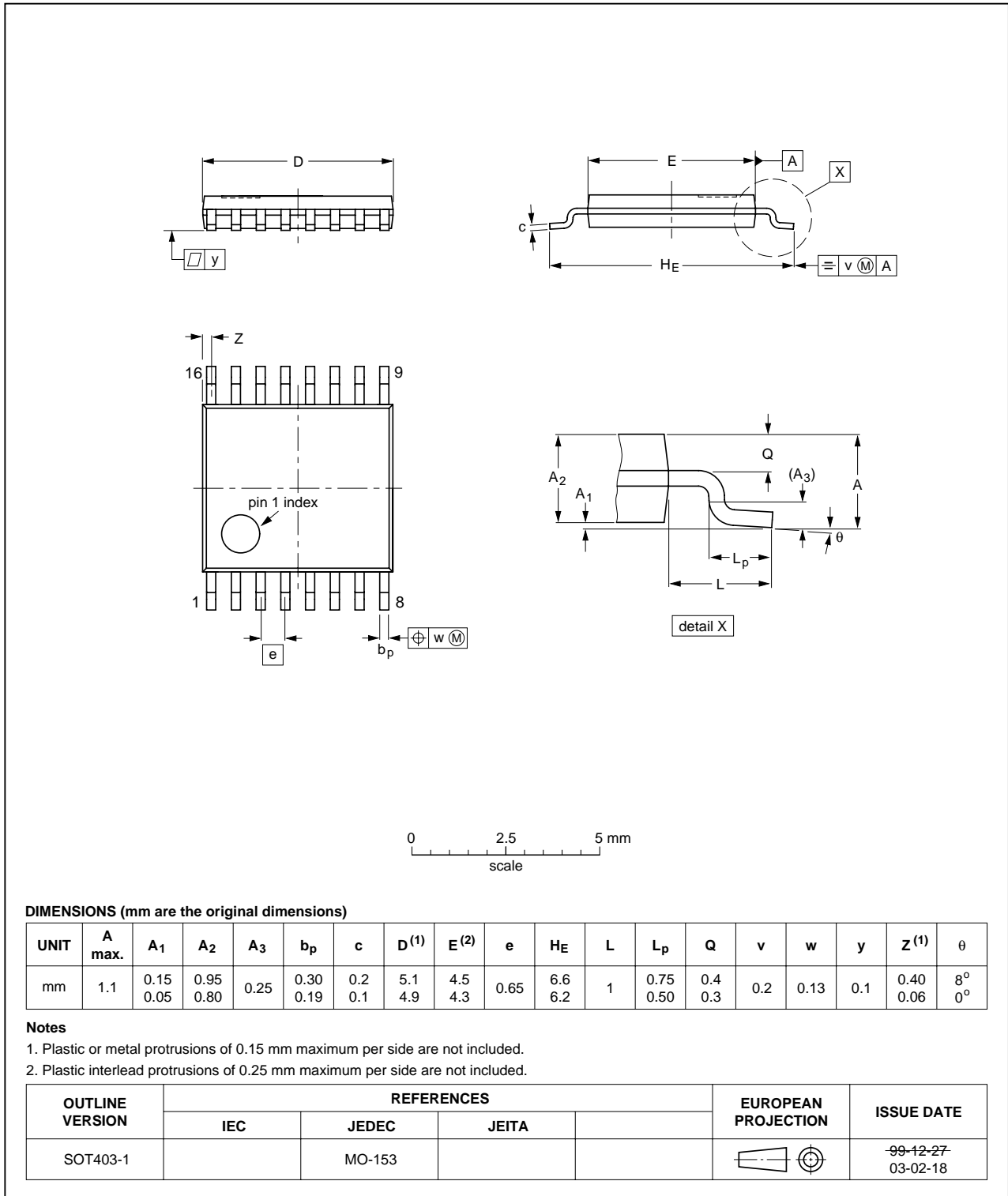

Fig 20. Package outline SOT403-1 (TSSOP16)

SSOP20: plastic shrink small outline package; 20 leads; body width 4.4 mm

SOT266-1

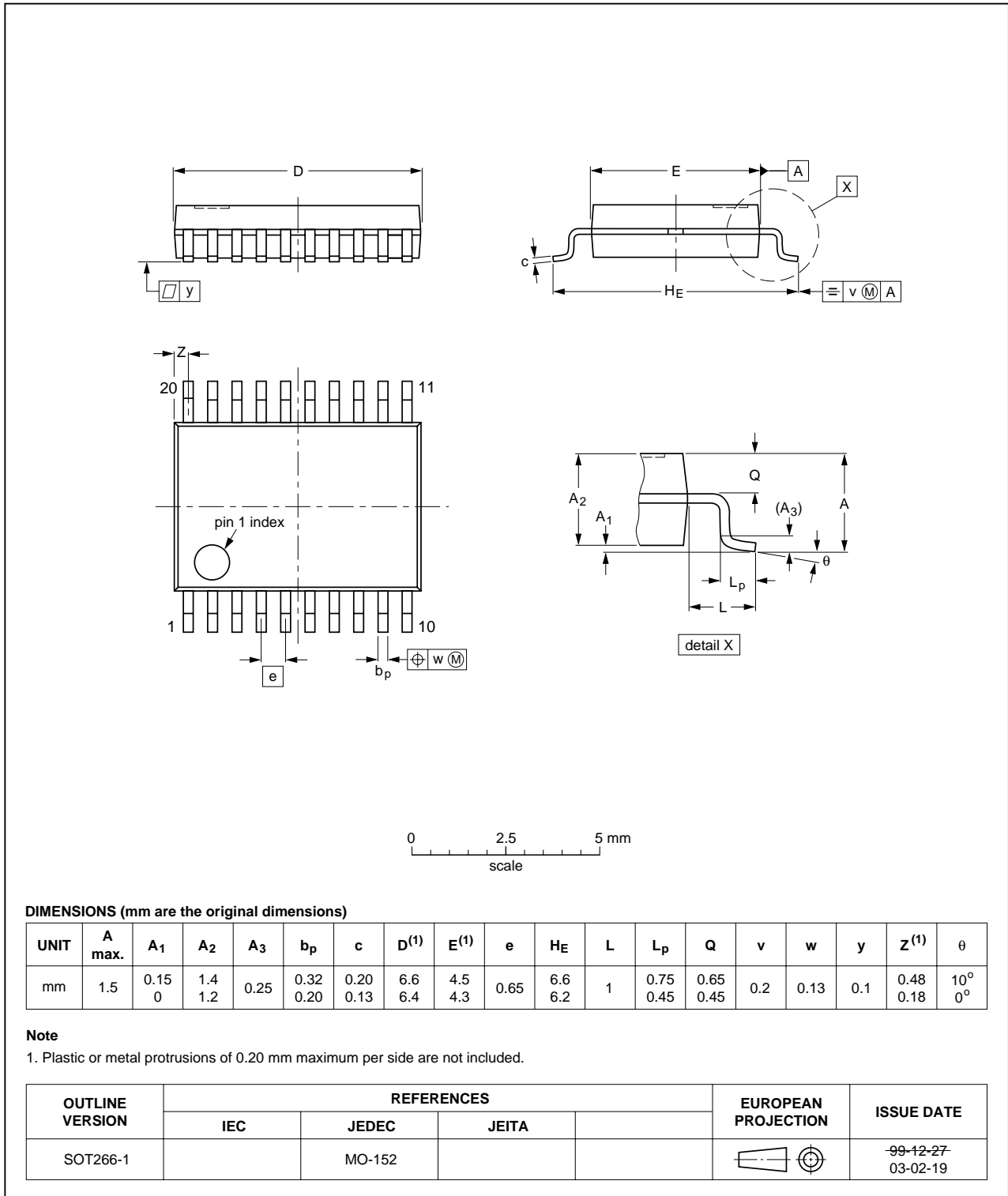

Fig 21. Package outline SOT266-1 (SSOP20)

15. Handling information

Inputs and outputs are protected against electrostatic discharge in normal handling. However, to be completely safe you must take normal precautions appropriate to handling integrated circuits.

16. Soldering

16.1 Introduction

There is no soldering method that is ideal for all surface mount IC packages. Wave soldering can still be used for certain surface mount ICs, but it is not suitable for fine pitch SMDs. In these situations reflow soldering is recommended.

16.2 Through-hole mount packages

16.2.1 Soldering by dipping or by solder wave

Typical dwell time of the leads in the wave ranges from 3 seconds to 4 seconds at 250 °C or 265 °C, depending on solder material applied, SnPb or Pb-free respectively.

The total contact time of successive solder waves must not exceed 5 seconds.

The device may be mounted up to the seating plane, but the temperature of the plastic body must not exceed the specified maximum storage temperature ($T_{stg(max)}$). If the printed-circuit board has been pre-heated, forced cooling may be necessary immediately after soldering to keep the temperature within the permissible limit.

16.2.2 Manual soldering

Apply the soldering iron (24 V or less) to the lead(s) of the package, either below the seating plane or not more than 2 mm above it. If the temperature of the soldering iron bit is less than 300 °C it may remain in contact for up to 10 seconds. If the bit temperature is between 300 °C and 400 °C, contact may be up to 5 seconds.

16.3 Surface mount packages

16.3.1 Reflow soldering

Key characteristics in reflow soldering are:

- Lead-free versus SnPb soldering; note that a lead-free reflow process usually leads to higher minimum peak temperatures (see [Figure 22](#)) than a PbSn process, thus reducing the process window
- Solder paste printing issues including smearing, release, and adjusting the process window for a mix of large and small components on one board
- Reflow temperature profile; this profile includes preheat, reflow (in which the board is heated to the peak temperature) and cooling down. It is imperative that the peak temperature is high enough for the solder to make reliable solder joints (a solder paste characteristic). In addition, the peak temperature must be low enough that the

packages and/or boards are not damaged. The peak temperature of the package depends on package thickness and volume and is classified in accordance with [Table 9](#) and [10](#)

Table 9. SnPb eutectic process (from J-STD-020C)

Package thickness (mm)	Package reflow temperature (°C)	
	Volume (mm ³)	
	< 350	≥ 350
< 2.5	235	220
≥ 2.5	220	220

Table 10. Lead-free process (from J-STD-020C)

Package thickness (mm)	Package reflow temperature (°C)		
	Volume (mm ³)		
	< 350	350 to 2000	> 2000
< 1.6	260	260	260
1.6 to 2.5	260	250	245
> 2.5	250	245	245

Moisture sensitivity precautions, as indicated on the packing, must be respected at all times.

Studies have shown that small packages reach higher temperatures during reflow soldering, see [Figure 22](#).

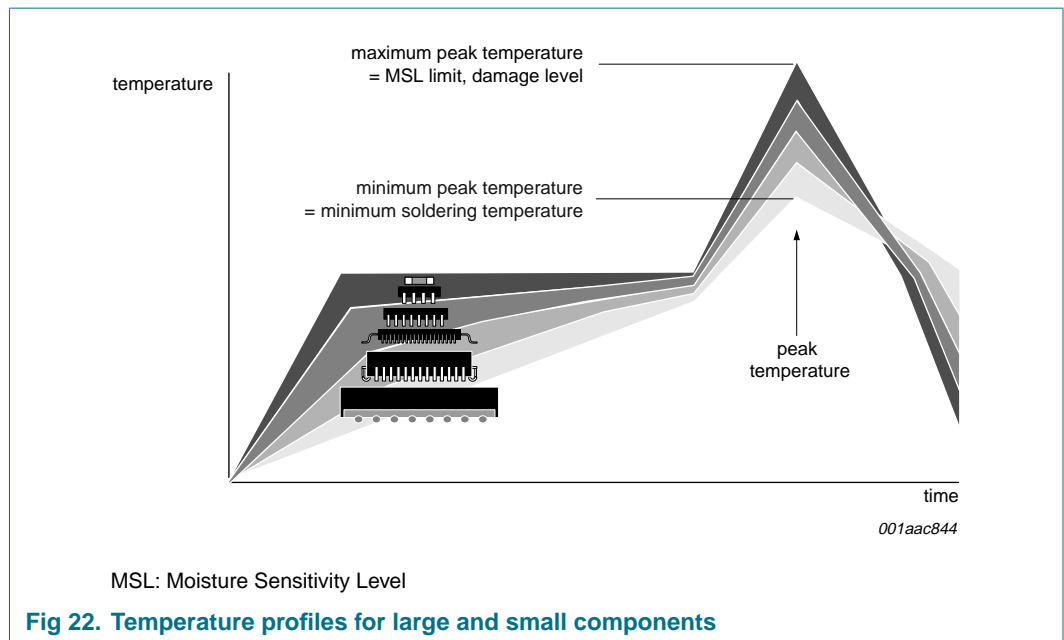

For further information on temperature profiles, refer to Application Note AN10365 "Surface mount reflow soldering description".

16.3.2 Wave soldering

Conventional single wave soldering is not recommended for surface mount devices (SMDs) or printed-circuit boards with a high component density, as solder bridging and non-wetting can present major problems.

To overcome these problems the double-wave soldering method was specifically developed.

If wave soldering is used the following conditions must be observed for optimal results:

- Use a double-wave soldering method comprising a turbulent wave with high upward pressure followed by a smooth laminar wave.
- For packages with leads on two sides and a pitch (e):
 - larger than or equal to 1.27 mm, the footprint longitudinal axis is **preferred** to be parallel to the transport direction of the printed-circuit board;
 - smaller than 1.27 mm, the footprint longitudinal axis **must** be parallel to the transport direction of the printed-circuit board.

The footprint must incorporate solder thieves at the downstream end.

- For packages with leads on four sides, the footprint must be placed at a 45° angle to the transport direction of the printed-circuit board. The footprint must incorporate solder thieves downstream and at the side corners.

During placement and before soldering, the package must be fixed with a droplet of adhesive. The adhesive can be applied by screen printing, pin transfer or syringe dispensing. The package can be soldered after the adhesive is cured.

Typical dwell time of the leads in the wave ranges from 3 seconds to 4 seconds at 250 °C or 265 °C, depending on solder material applied, SnPb or Pb-free respectively.

A mildly-activated flux will eliminate the need for removal of corrosive residues in most applications.

16.3.3 Manual soldering

Fix the component by first soldering two diagonally-opposite end leads. Use a low voltage (24 V or less) soldering iron applied to the flat part of the lead. Contact time must be limited to 10 seconds at up to 300 °C.

When using a dedicated tool, all other leads can be soldered in one operation within 2 seconds to 5 seconds between 270 °C and 320 °C.

16.4 Package related soldering information

Table 11. Suitability of IC packages for wave, reflow and dipping soldering methods

Mounting	Package ^[1]	Soldering method		
		Wave	Reflow ^[2]	Dipping
Through-hole mount	CPGA, HCPGA	suitable	–	–
	DBS, DIP, HDIP, RDBS, SDIP, SIL	suitable ^[3]	–	suitable
Through-hole-surface mount	PMFP ^[4]	not suitable	not suitable	–

Table 11. Suitability of IC packages for wave, reflow and dipping soldering methods ...continued

Mounting	Package ^[1]	Soldering method		
		Wave	Reflow ^[2]	Dipping
Surface mount	BGA, HTSSON..T ^[5] , LBGA, LFBGA, SQFP, SSOP..T ^[5] , TFBGA, VFBGA, XSON	not suitable	suitable	–
	DHVQFN, HBCC, HBGA, HLQFP, HSO, HSOP, HSQFP, HSSON, HTQFP, HTSSOP, HVQFN, HVSON, SMS	not suitable ^[6]	suitable	–
	PLCC ^[7] , SO, SOJ	suitable	suitable	–
	LQFP, QFP, TQFP	not recommended ^{[7][8]}	suitable	–
	SSOP, TSSOP, VSO, VSSOP	not recommended ^[9]	suitable	–
	CWQCCN..L ^[10] , WQCCN..L ^[10]	not suitable	not suitable	–

- [1] For more detailed information on the BGA packages refer to the (LF)BGA Application Note (AN01026); order a copy from your NXP Semiconductors sales office.
- [2] All surface mount (SMD) packages are moisture sensitive. Depending upon the moisture content, the maximum temperature (with respect to time) and body size of the package, there is a risk that internal or external package cracks may occur due to vaporization of the moisture in them (the so called popcorn effect).
- [3] For SDIP packages, the longitudinal axis must be parallel to the transport direction of the printed-circuit board.
- [4] Hot bar soldering or manual soldering is suitable for PMFP packages.
- [5] These transparent plastic packages are extremely sensitive to reflow soldering conditions and must on no account be processed through more than one soldering cycle or subjected to infrared reflow soldering with peak temperature exceeding 217 °C ± 10 °C measured in the atmosphere of the reflow oven. The package body peak temperature must be kept as low as possible.
- [6] These packages are not suitable for wave soldering. On versions with the heatsink on the bottom side, the solder cannot penetrate between the printed-circuit board and the heatsink. On versions with the heatsink on the top side, the solder might be deposited on the heatsink surface.
- [7] If wave soldering is considered, then the package must be placed at a 45° angle to the solder wave direction. The package footprint must incorporate solder thieves downstream and at the side corners.
- [8] Wave soldering is suitable for LQFP, QFP and TQFP packages with a pitch (e) larger than 0.8 mm; it is definitely not suitable for packages with a pitch (e) equal to or smaller than 0.65 mm.
- [9] Wave soldering is suitable for SSOP, TSSOP, VSO and VSSOP packages with a pitch (e) equal to or larger than 0.65 mm; it is definitely not suitable for packages with a pitch (e) equal to or smaller than 0.5 mm.
- [10] Image sensor packages in principle should not be soldered. They are mounted in sockets or delivered pre-mounted on flex foil. However, the image sensor package can be mounted by the client on a flex foil by using a hot bar soldering process. The appropriate soldering profile can be provided on request.

17. Abbreviations

Table 12. Abbreviations

Acronym	Description
CDM	Charged Device Model
CMOS	Complementary Metal Oxide Semiconductor
ESD	ElectroStatic Discharge
GPIO	General Purpose Input/Output
HBM	Human Body Model
LED	Light Emitting Diode
IC	Integrated Circuit
I ² C-bus	Inter-Integrated Circuit bus
ID	Identification
LSB	Least Significant Bit
MM	Machine Model
MSB	Most Significant Bit
PLC	Programmable Logic Controller
PWM	Pulse Width Modulation
RAID	Redundant Array of Independent Disks
SMBus	System Management Bus

18. Revision history

Table 13. Revision history

Document ID	Release date	Data sheet status	Change notice	Supersedes
PCA8574_PCA8574A_2	20070514	Product data sheet	-	PCA8574_PCA8574A_1
Modifications:				
<ul style="list-style-type: none"> • Section 2 "Features", last bullet item: changed "TSSOP20" to "TSSOP16" • Table 1 "Ordering information": changed package from TSSOP20 (SOT360-1) to TSSOP16 (SOT403-1) • Section 6.1 "Pinning": deleted pin configuration for TSSOP20; added pin configuration for TSSOP16 • Table 2 title changed (added TSSOP16) • Table 3 title changed (deleted TSSOP20) • Section 14 "Package outline": changed package from TSSOP20 (SOT360-1) to TSSOP16 (SOT403-1) 				
PCA8574_PCA8574A_1	20070117	Product data sheet	-	-

19. Legal information

19.1 Data sheet status

Document status ^{[1][2]}	Product status ^[3]	Definition
Objective [short] data sheet	Development	This document contains data from the objective specification for product development.
Preliminary [short] data sheet	Qualification	This document contains data from the preliminary specification.
Product [short] data sheet	Production	This document contains the product specification.

[1] Please consult the most recently issued document before initiating or completing a design.

[2] The term 'short data sheet' is explained in section "Definitions".

[3] The product status of device(s) described in this document may have changed since this document was published and may differ in case of multiple devices. The latest product status information is available on the Internet at URL <http://www.nxp.com>.

19.2 Definitions

Draft — The document is a draft version only. The content is still under internal review and subject to formal approval, which may result in modifications or additions. NXP Semiconductors does not give any representations or warranties as to the accuracy or completeness of information included herein and shall have no liability for the consequences of use of such information.

Short data sheet — A short data sheet is an extract from a full data sheet with the same product type number(s) and title. A short data sheet is intended for quick reference only and should not be relied upon to contain detailed and full information. For detailed and full information see the relevant full data sheet, which is available on request via the local NXP Semiconductors sales office. In case of any inconsistency or conflict with the short data sheet, the full data sheet shall prevail.

19.3 Disclaimers

General — Information in this document is believed to be accurate and reliable. However, NXP Semiconductors does not give any representations or warranties, expressed or implied, as to the accuracy or completeness of such information and shall have no liability for the consequences of use of such information.

Right to make changes — NXP Semiconductors reserves the right to make changes to information published in this document, including without limitation specifications and product descriptions, at any time and without notice. This document supersedes and replaces all information supplied prior to the publication hereof.

Suitability for use — NXP Semiconductors products are not designed, authorized or warranted to be suitable for use in medical, military, aircraft, space or life support equipment, nor in applications where failure or malfunction of a NXP Semiconductors product can reasonably be expected to

result in personal injury, death or severe property or environmental damage. NXP Semiconductors accepts no liability for inclusion and/or use of NXP Semiconductors products in such equipment or applications and therefore such inclusion and/or use is at the customer's own risk.

Applications — Applications that are described herein for any of these products are for illustrative purposes only. NXP Semiconductors makes no representation or warranty that such applications will be suitable for the specified use without further testing or modification.

Limiting values — Stress above one or more limiting values (as defined in the Absolute Maximum Ratings System of IEC 60134) may cause permanent damage to the device. Limiting values are stress ratings only and operation of the device at these or any other conditions above those given in the Characteristics sections of this document is not implied. Exposure to limiting values for extended periods may affect device reliability.

Terms and conditions of sale — NXP Semiconductors products are sold subject to the general terms and conditions of commercial sale, as published at <http://www.nxp.com/profile/terms>, including those pertaining to warranty, intellectual property rights infringement and limitation of liability, unless explicitly otherwise agreed to in writing by NXP Semiconductors. In case of any inconsistency or conflict between information in this document and such terms and conditions, the latter will prevail.

No offer to sell or license — Nothing in this document may be interpreted or construed as an offer to sell products that is open for acceptance or the grant, conveyance or implication of any license under any copyrights, patents or other industrial or intellectual property rights.

19.4 Trademarks

Notice: All referenced brands, product names, service names and trademarks are the property of their respective owners.

I²C-bus — logo is a trademark of NXP B.V.

20. Contact information

For additional information, please visit: <http://www.nxp.com>

For sales office addresses, send an email to: salesaddresses@nxp.com

21. Contents

1	General description	1	19	Legal information	26
2	Features	1	19.1	Data sheet status	26
3	Applications	1	19.2	Definitions	26
4	Ordering information	2	19.3	Disclaimers	26
5	Block diagram	2	19.4	Trademarks	26
6	Pinning information	3	20	Contact information	26
6.1	Pinning	3	21	Contents	27
6.2	Pin description	4			
7	Functional description	6			
7.1	Device address	6			
7.1.1	Address maps	6			
8	I/O programming	7			
8.1	Quasi-bidirectional I/O architecture	7			
8.2	Writing to the port (Output mode)	7			
8.3	Reading from a port (Input mode)	8			
8.4	Power-on reset	9			
8.5	Interrupt output ($\overline{\text{INT}}$)	9			
9	Characteristics of the I²C-bus	10			
9.1	Bit transfer	10			
9.1.1	START and STOP conditions	10			
9.2	System configuration	10			
9.3	Acknowledge	11			
10	Application design-in information	12			
10.1	Bidirectional I/O expander applications	12			
10.2	High current-drive load applications	12			
11	Limiting values	13			
12	Static characteristics	14			
13	Dynamic characteristics	15			
14	Package outline	17			
15	Handling information	21			
16	Soldering	21			
16.1	Introduction	21			
16.2	Through-hole mount packages	21			
16.2.1	Soldering by dipping or by solder wave	21			
16.2.2	Manual soldering	21			
16.3	Surface mount packages	21			
16.3.1	Reflow soldering	21			
16.3.2	Wave soldering	23			
16.3.3	Manual soldering	23			
16.4	Package related soldering information	23			
17	Abbreviations	25			
18	Revision history	25			

Please be aware that important notices concerning this document and the product(s) described herein, have been included in section 'Legal information'.



© NXP B.V. 2007.

All rights reserved.

For more information, please visit: <http://www.nxp.com>

For sales office addresses, please send an email to: salesaddresses@nxp.com

Date of release: 14 May 2007

Document identifier: PCA8574_PCA8574A_2