



## Product Overview

### NCS36510: Low Power System-on-Chip For 2.4 GHz IEEE 802.15.4 Applications Including Zigbee®, Thread®, and Proprietary

For complete documentation, see the data sheet.



The NCS36510 is a low power, fully integrated, System on Chip that integrates a 2.4 GHz IEEE 802.15.4 compliant transceiver, ARM® Cortex®-M3 microprocessor, RAM and FLASH memory, a true random number generator, and multiple peripherals to support design of a complete and secure wireless network with minimal external components. The NCS36510 offers advanced power management techniques that allow operation down to supply voltages as low as 1 V while minimizing current consumption. The NCS36510 is specifically designed for applications requiring maximum battery life while minimizing cost. The NCS36510 incorporates an industry leading 32 bit ARM Cortex-M3 for high performance, low power and low cost processing. The NCS36510 includes 640 kB of embedded FLASH memory for program storage along with 48 kB of RAM for data storage. NCS36510 uses a hardware accelerated MAC to minimize processor overhead while maximizing available processor power for running application software. Peripherals include DMA, UART(2), SPI(2), I2C(2), PWM, RTC, three programmable timers, WDT, 18 GPIO, 10 bit ADC with four external inputs and integrated temperature and voltage sensors. Available software includes an 802.15.4 MAC layer demo application, a Zigbee 3.0 certified stack with example applications, and a Thread demo. All available software is linked below in the software section.

#### Features

- Low Voltage Operation (as low as 1.0V)
  - Ultra-Low Transmit Power Consumption (as low as 6.9mW)
  - Ultra-Low Receive Power Consumption (as low as 6.6mW)
  - Multiple Sleep Modes (Including 0.65 µA Coma Mode Sleep Current, 0.18 µA Coma Mode Leakage Current)
  - Antenna Diversity
  - Embedded Memory Configurations (640 kB FLASH and 48kB RAM)
  - Exceptional Receiver Sensitivity of -99 dBm
  - Programmable Output Power Up to ~8 dBm
  - Supports external LNA & PA
  - 2.4 GHz IEEE 802.15.4-2006 Transceiver PHY and MAC
- For more features, see the data sheet

#### Benefits

- Enables Alternative Energy Sources (ex. energy harvesting, low voltage batteries)
- Extended Battery Life, Energy Conservation
- Extended Battery Life, Energy Conservation
- Extended Battery Life, Energy Conservation
- Increases Link Budget ~6 dB

#### Applications

- Internet of Things (IOT)
- IEEE 802.15.4 Applications
- Connected Home - Security, Automation, and Lighting
- Building and Industrial Automation
- Smart Grid Applications

#### End Products

- Energy Harvesting and/or Battery Powered Sensor Nodes
- Smart Meters
- Thermostats
- Electronic Security Devices & Controls (Door Locks, etc.)
- Smoke/Carbon-Monoxide Detectors & Alarms

### Part Electrical Specifications

Product	Pricing (\$/Unit)	Compliance	Status	Data Transmission Standard	Frequency Band (MHz)	Carrier Frequency (MHz)	Package Type
NCS36510MNTXG	2.1538	Pb-free Halide free non AEC-Q and PPAP	Active	RF	2400-2480	2400-2480	QFN-40

## Application Diagram

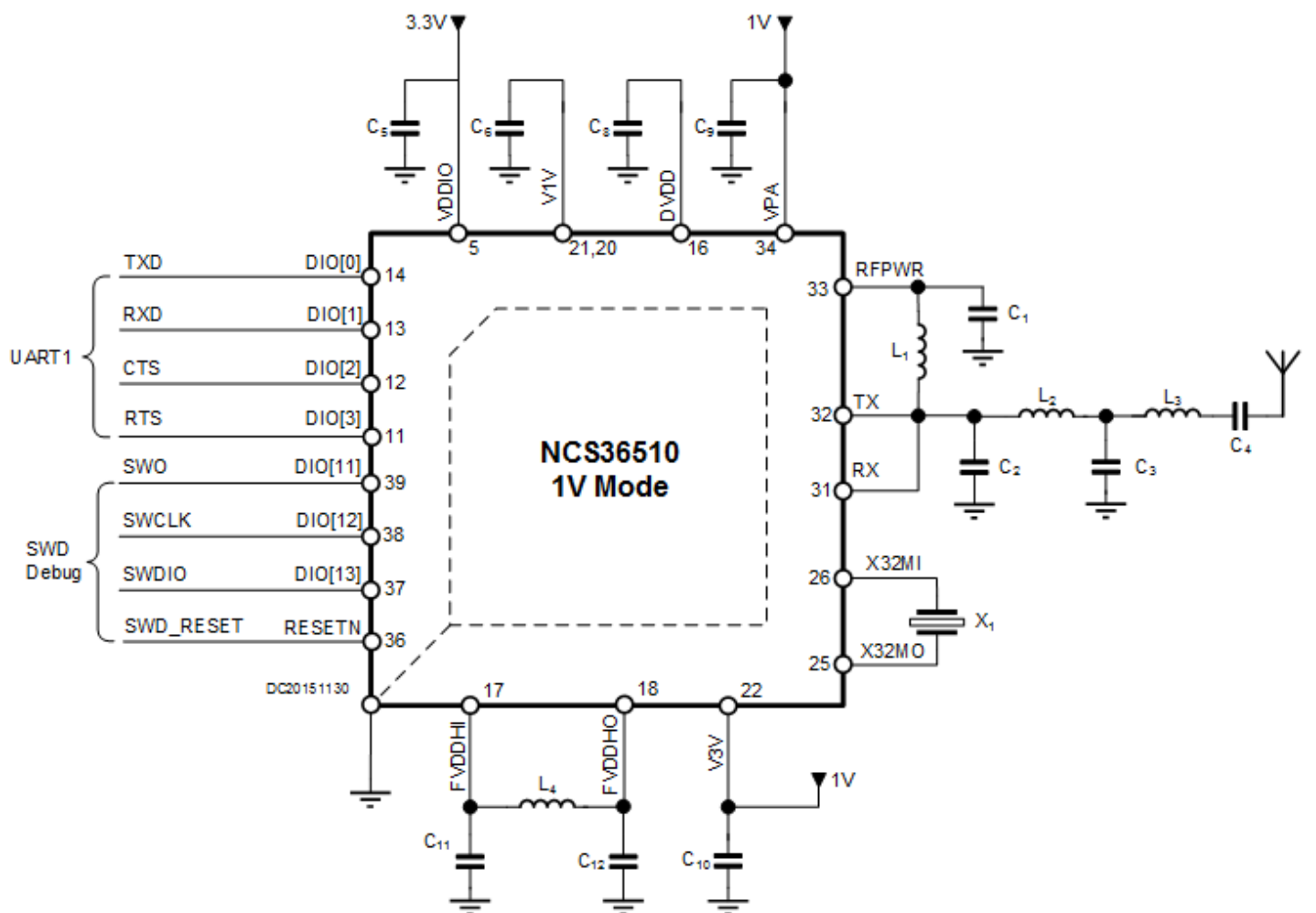
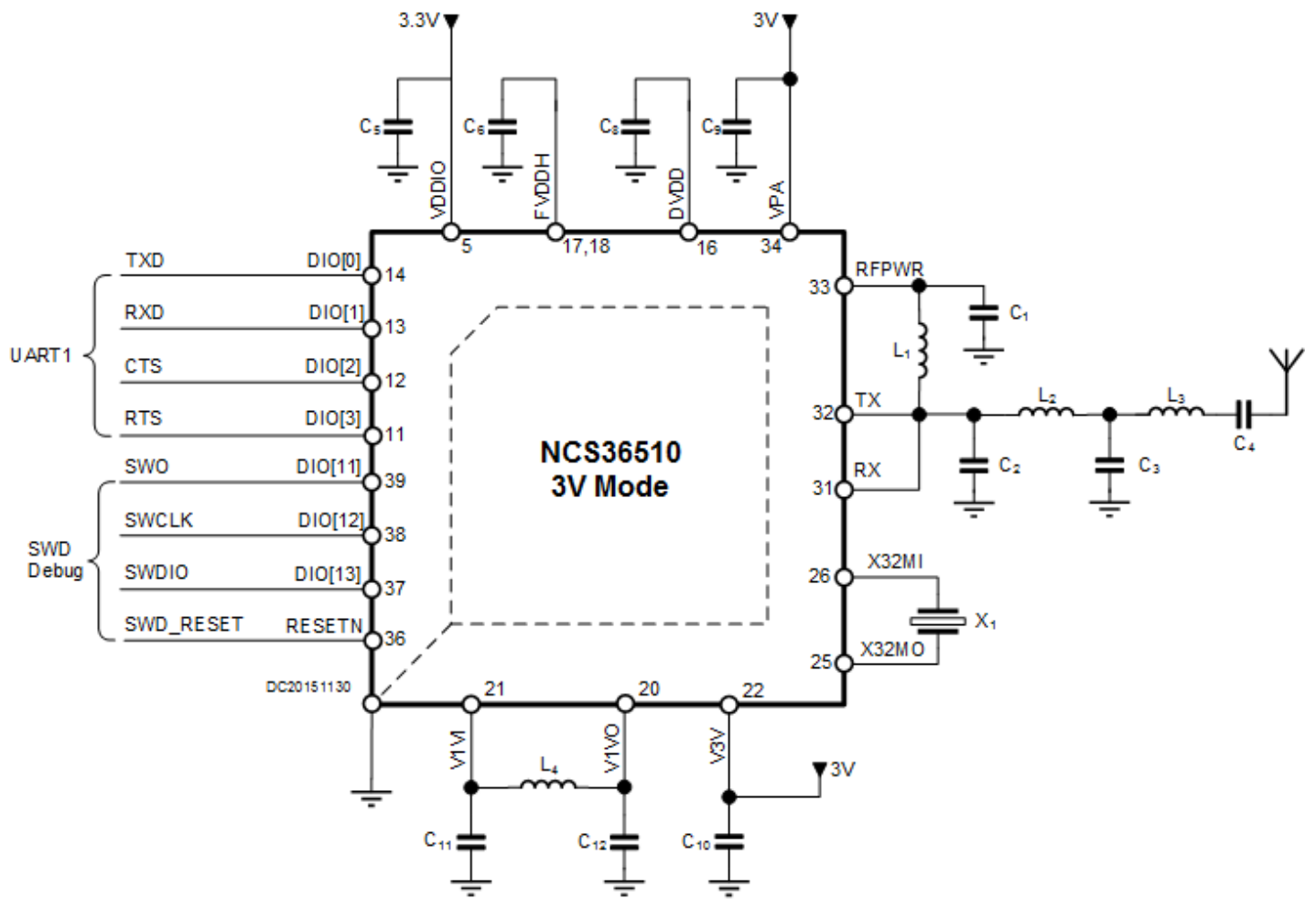

For more information please contact your local sales support at [www.onsemi.com](http://www.onsemi.com).

Created on: 10/17/2021