

High voltage ignition coil driver power integrated circuit

Type	V _{cl}	I _{cl}	I _{d(on)}
VB027SP-E	300 V	9 A	130 mA

Features

- ECOPACK®: lead free and RoHS compliant
- Automotive Grade: compliance with AEC guidelines
- Primary coil voltage internally set
- Coil current limit internally set
- Logic level compatible input
- Driving current quasi proportional to collector current
- Double flag-on coil current

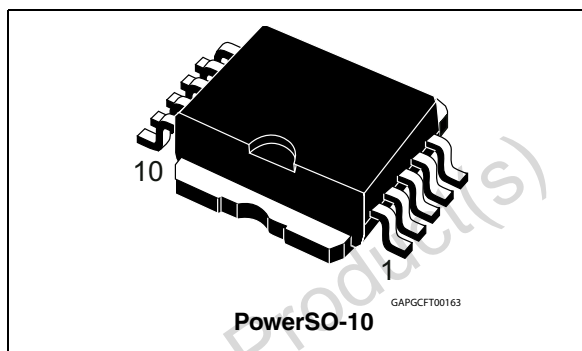

Description

The VB027SP-E is a high voltage power integrated circuit made using the STMicroelectronics™ VIPower™ technology, with vertical current flow power darlington and logic level compatible driving circuit.

Built-in protection circuit for coil current limiting and collector voltage clamping allows the device to be used as smart, high voltage, high current interface in advanced electronic ignition system.

Table 1. Device summary

Package	Order code	
	Tube	Tape and reel
PowerSO-10	VB027SP-E	VB027SPTR-E

Contents

1	Block diagram and pins description	5
2	Electrical specifications	6
2.1	Absolute maximum ratings	6
2.2	Thermal data	6
2.3	Electrical characteristics	7
2.4	Electrical characteristics curves	8
3	Application information	9
3.1	Principle of operation	9
3.2	Thermal behaviour	9
3.3	Overvoltage	10
4	Package and packing information	11
4.1	ECOPACK®	11
4.2	PowerSO-10 mechanical data	11
5	Revision history	13

List of tables

Table 1.	Device summary	1
Table 2.	Pin function	5
Table 3.	Absolute maximum ratings	6
Table 4.	Thermal data	6
Table 5.	Electrical characteristics	7
Table 6.	PowerSO-10 mechanical data	11
Table 7.	Document revision history	13

Obsolete Product(s) - Obsolete Product(s)

List of figures

Figure 1.	Block diagram	5
Figure 2.	Configuration diagram (top view)	5
Figure 3.	Maximum I_{cl} vs temperature	8
Figure 4.	$I_{C(diag1)}$ vs temperature	8
Figure 5.	$I_{C(diag2)}$ vs temperature	8
Figure 6.	Application circuit	10
Figure 7.	Switching waveform	10
Figure 8.	PowerSO-10 package dimensions	12

Obsolete Product(s) - Obsolete Product(s)

1 Block diagram and pins description

Figure 1. Block diagram

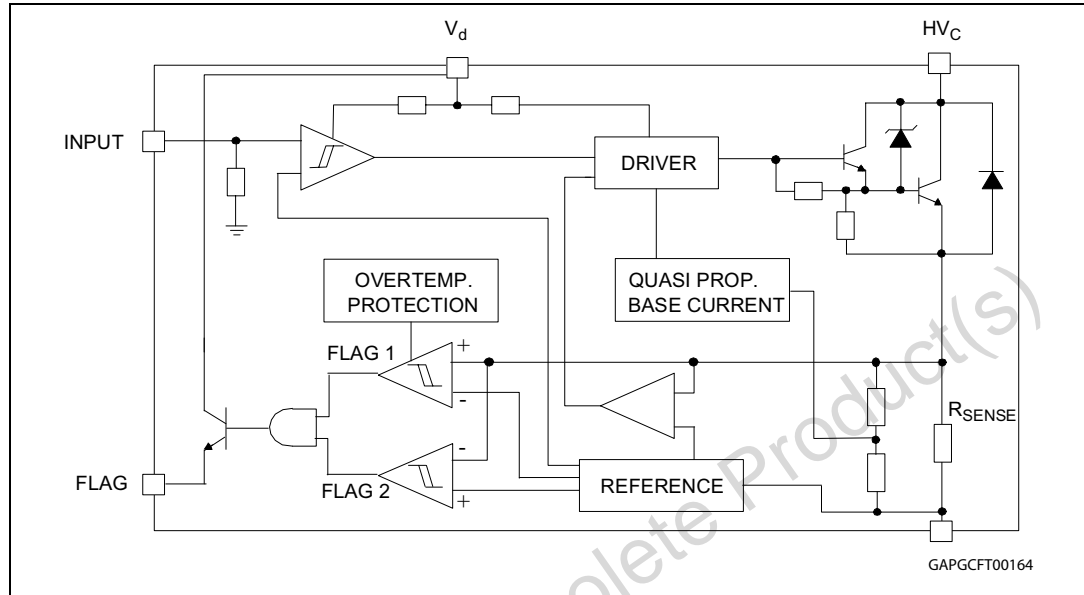

Figure 2. Configuration diagram (top view)

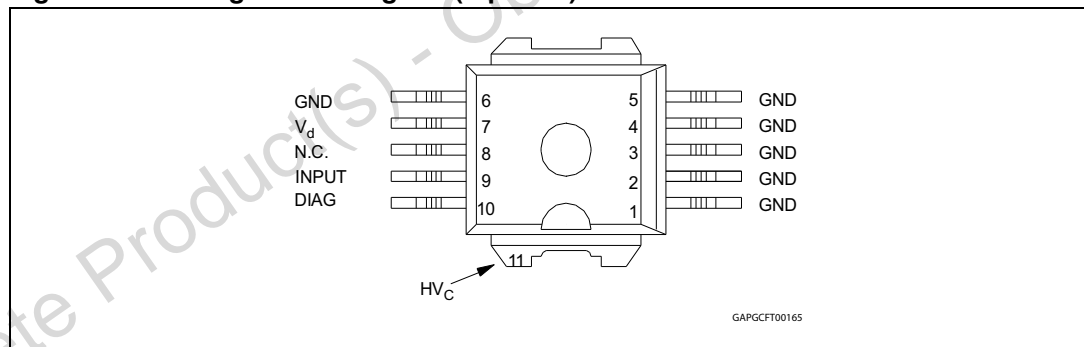

Table 2. Pin function

Pin number	Name	Function
1÷5	GND	Emitter power ground
6 ⁽¹⁾	GND	Control ground
7	V _d	Driving stage supply voltage
8	N.C.	
9	INPUT	Logic input channel
10	DIAG	Diagnostic output signal
TAB	HV _c	Primary coil output signal

1. Pin 1÷5 = power GND, pin 6 = signal GND. Pin 6 must be connected to pins 1÷5 externally.

2 Electrical specifications

2.1 Absolute maximum ratings

Stressing the device above the rating listed in the Table 3: Absolute maximum ratings may cause permanent damage to the device. These are stress ratings only and operation of the device at these or any other conditions above those indicated in the operating sections of this specification is not implied. Exposure to absolute maximum rating conditions for extended periods may affect device reliability. Refer also to the STMicroelectronics SURE program and other relevant quality documents.

Table 3. Absolute maximum ratings

Symbol	Parameter	Value	Unit
HV_C	Collector voltage	Internally limited	V
I_C	Collector current	Internally limited	A
V_d	Driving stage supply voltage	7	V
I_d	Driving circuitry supply current	200	mA
V_{IN}	Input voltage	10	V
T_j	Junction operating temperature	-40 to 150	°C
T_{stg}	Storage temperature	-55 to 150	°C

2.2 Thermal data

Table 4. Thermal data

Symbol	Parameter	Value	Unit
$R_{thj-case}$	Thermal resistance junction-case (MAX)	1.12	°C/W
$R_{thj-amb}$	Thermal resistance junction-ambient (MAX)	62.5	°C/W

2.3 Electrical characteristics

$V_{CC} = 13.5\text{ V}$; $V_d = 5\text{ V}$; $T_j = 25\text{ °C}$; $R_{coil} = 510\text{ m}\Omega$; $L_{coil} = 7\text{ mH}$ unless otherwise specified.

Table 5. Electrical characteristics

Symbol	Parameter	Test conditions	Min	Typ	Max	Unit
V_{cl}	High voltage clamp	$V_{IN} = 0.4\text{ V}$; $-40\text{ °C} \leq T_j \leq 125\text{ °C}$; $I_C = 6\text{ A}$	300	360	400	V
$V_{cg(sat)}$	Power stage saturation voltage	$I_C = 6\text{ A}$; $V_{IN} = 4\text{ V}$; $I_d = 80\text{ mA}$		1.5		V
$V_{cg(sat)td}$	Power stage saturation voltage derating in temperature	$I_C = 6\text{ A}$; $V_{IN} = 4\text{ V}$; $-40\text{ °C} \leq T_j \leq 125\text{ °C}$; $I_d = 85\text{ mA}$			2	V
$I_{d(off)}$	Power-off supply current	$V_{IN} = 0.4\text{ V}$			8	mA
$I_{d(on)}$	Power-on supply current	$V_{IN} = 4\text{ V}$; $I_C = 6\text{ A}$; $-40\text{ °C} \leq T_j \leq 125\text{ °C}$			130	mA
V_d	Driving stage supply voltage		4.5		5.5	V
I_{cl}	Collector current limit	$V_{IN} = 4\text{ V}^{(1)}$	8	8.5	9	A
$I_{cl(td)}$	Collector current limit drift with temperature	See Figure 3				
V_{INH}	High level input voltage	$HV_C < 2\text{ V}$	4		5.5	V
V_{INL}	Low level input voltage	$I_C < 2\text{ mA}$; $HV_C = V_{CC}$	0		0.8	V
I_{INH}	High level input current	$V_{IN} = 4\text{ V}$	40		200	μA
V_{diagH}	High level diagnostic output voltage	$R_{EXT} = 22\text{ K}\Omega$ (See Figure 6)	3.5	⁽²⁾	V_d	V
V_{diagL}	Low level diagnostic output voltage	$R_{EXT} = 22\text{ K}\Omega$ (See Figure 6)			0.5	V
$I_{C(diag1)}$	First threshold level collector current		4.25	4.5	4.75	A
$I_{C(diag1)td}$	First threshold level collector current drift with temperature	See Figure 4				
$I_{C(diag2)}$	Second threshold level collector current		5.45	5.8	6.15	A
$I_{C(diag2)td}$	Second threshold level collector current drift with temperature	See Figure 5				
$t_{d(off)}$	Turn-off delay time of output current	$I_C = 5.5\text{ A}$		25		μs
$t_{f(off)}$	Turn-off fall time of output current	$I_C = 5.5\text{ A}$		8		μs
$t_{d(diag)}$	Delay time of diagnostic current	$R_{EXT} = 22\text{ K}\Omega$ (See Figure 6)		1		μs
$t_{r(diag)}$	Turn-on rise time of diagnostic current	$R_{EXT} = 22\text{ K}\Omega$ (See Figure 6)		1		μs
$t_{f(diag)}$	Turn-off fall time of diagnostic current	$R_{EXT} = 22\text{ K}\Omega$ (See Figure 6)		1		μs

1. The primary coil current value I_{cl} must be measured 1 ms after desaturation of the power stage.

2. $V_d - V_{be(on)}$.

2.4 Electrical characteristics curves

Figure 3. Maximum I_{cI} vs temperature

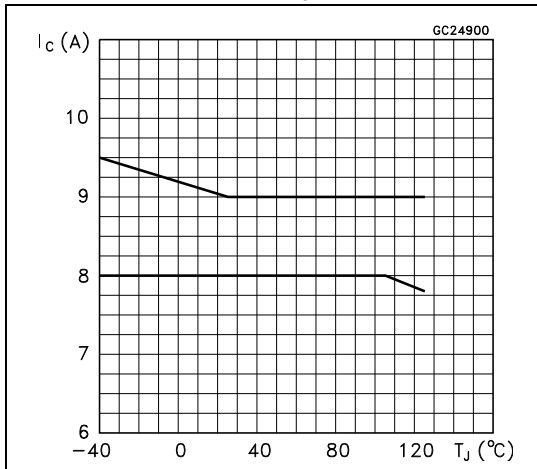

Figure 4. $I_{c(diag1)}$ vs temperature

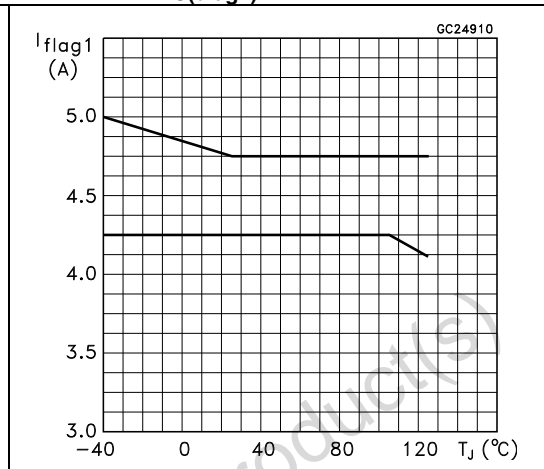
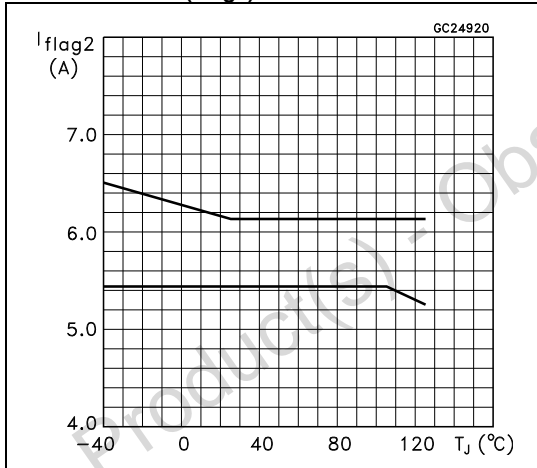

Figure 5. $I_{c(diag2)}$ vs temperature



3 Application information

3.1 Principle of operation

The VB027SP-E is mainly intended as high voltage power switch device driven by a logic level input and interfaces directly to a high energy electronic ignition coil.

The input V_{IN} of the VB027SP-E is fed from a low power signal generated by an external controller that determines both dwell time and ignition point. During V_{IN} high (≥ 4 V) the VB027SP-E increases current in the coil to the desired, internally set current level.

When the collector current exceeds 4.5 A, the diagnostic signal is turned high and it remains so, until the load current reaches 5.8 A (second threshold). At that value, the diagnostic signal is turned low, and the μC forces the V_{IN} to the low state. During the coil current switch-off, the primary voltage HV_C is clamped by a series of Zener diodes at an internally set value V_{Cl} , typically 360 V.

The collector current sensed through the R_{sense} , is limited thanks to the "Current limiter" block that, as soon as the I_{Cl} level is reached, forces the darlington (using the "Driver" block) to limit the current provided.

The transition from saturation to desaturation, coil current limiting phase, must have the ability to accommodate an overvoltage. A maximum overshoot of 20 V is allowed. There can be some short period of time in which the output pin (HV_C) is pulled below ground by a negative current due to leakage inductances and stray capacitances of the ignition coil. This can cause parasitic glitches on the diagnostic output. VB027SP-E has a built-in protection circuit that allows to lock the p-buried layer potential of the linear stage to the collector power, when the last one is pulled underground.

3.2 Thermal behaviour

You can see in the block diagram of the VB027SP-E (see [Figure 1](#)) a box called overtemperature protection. The purpose of this circuit is to shift the current level at which the first diagnostic is activated down of about 1 A.

This information can be managed by the micro that can take the corrective action in order to reduce the power dissipation. This block is not an effective protection but just an overtemperature detection. The shift down of the first flag level cannot be present for temperatures lower than 125 °C.

As an example of its behavior you can suppose a very simple motor management system in which the micro does just a simple arithmetic calculation to decide when to switch-off the device after the first flag threshold.

Example

$I_{C(DIAG1)}$ info after x ms ($I_{C(DIAG1)} = 2.5$ A)

$I_{switch-off}$ info after kx ms.

As soon as the temperature rises over the overtemperature threshold, the first diagnostic is shifted down to about 1.5 A and, in this example, the switch-off current is $kx * 1.5 / 2.5$.

3.3 Overvoltage

The VB027SP-E can withstand the following transients of the battery line:

-100 V / 2 ms ($R_i = 10 \Omega$)

+100 V / 0.2 ms ($R_i = 10 \Omega$)

+50 V / 400 ms ($R_i = 4.2 \Omega$, with $V_{IN} = 3 V$)

Figure 6. Application circuit

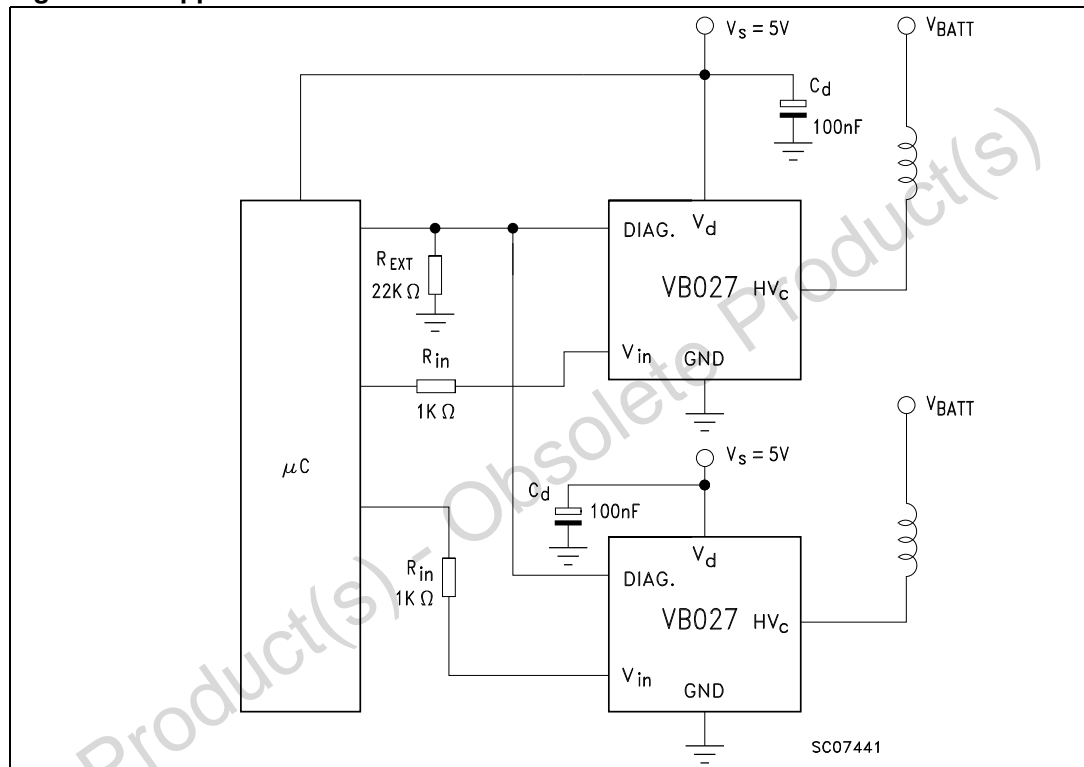
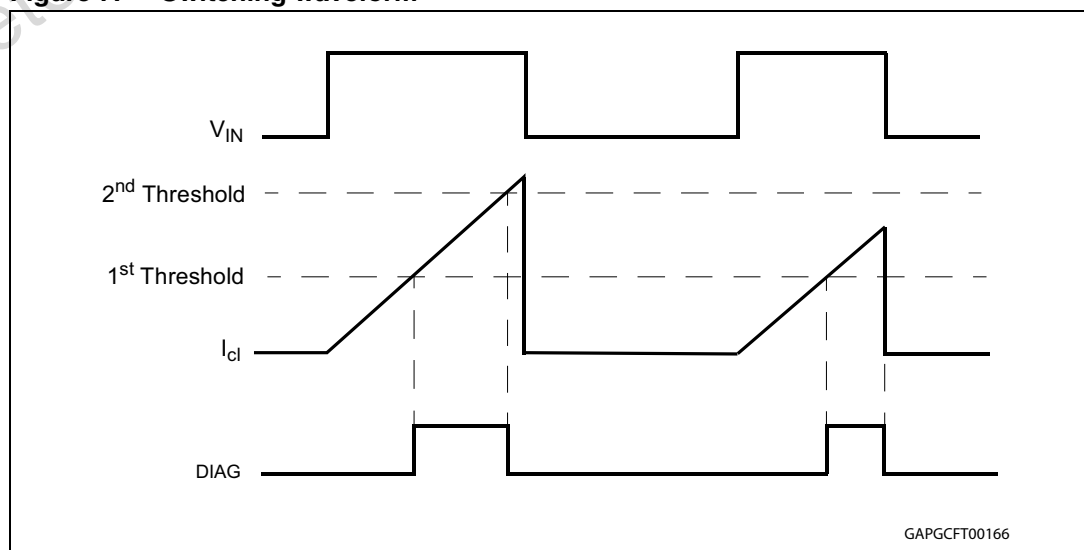

Figure 7. Switching waveform



4 Package and packing information

4.1 ECOPACK®

In order to meet environmental requirements, ST offers these devices in different grades of ECOPACK® packages, depending on their level of environmental compliance. ECOPACK® specifications, grade definitions and product status are available at: www.st.com. ECOPACK® is an ST trademark.

4.2 PowerSO-10 mechanical data

Table 6. PowerSO-10 mechanical data

Dim.	mm.			inch		
	Min.	Typ	Max.	Min.	Typ.	Max.
A	3.35		3.65	0.132		0.144
A1	0.00		0.10	0.000		0.004
B	0.40		0.60	0.016		0.024
c	0.35		0.55	0.013		0.022
D	9.40		9.60	0.370		0.378
D1	7.40		7.60	0.291		0.300
E	9.30		9.50	0.366		0.374
E1	7.20		7.40	0.283		0.291
E2	7.20		7.60	0.283		0.299
E3	6.10		6.35	0.240		0.250
E4	5.90		6.10	0.232		0.240
e		1.27			0.050	
F	1.25		1.35	0.049		0.053
H	13.80		14.40	0.543		0.567
h		0.50			0.002	
Q		1.70			0.067	
α	0°		8°			

Figure 8. PowerSO-10 package dimensions

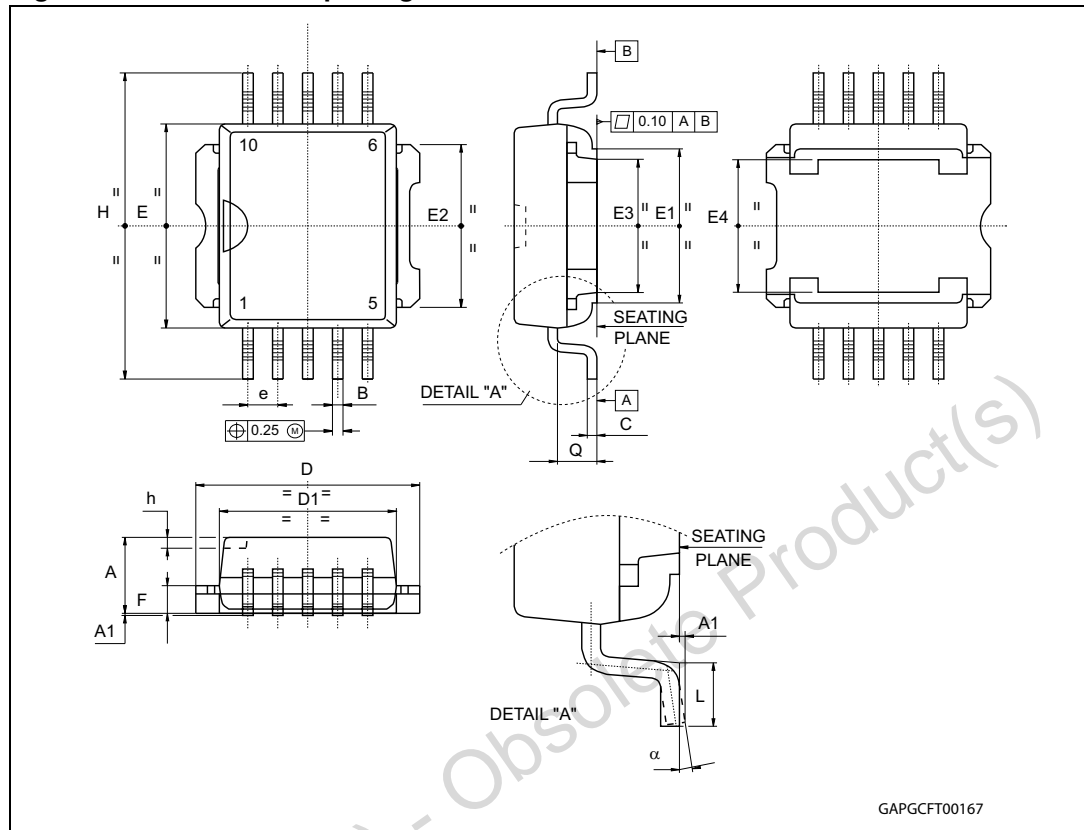

5 Revision history

Table 7. Document revision history

Date	Revision	Changes
14-May-2011	1	Initial release.
24-Sep-2013	2	Updated Disclaimer.

Obsolete Product(s) - Obsolete Product(s)

Please Read Carefully:

Information in this document is provided solely in connection with ST products. STMicroelectronics NV and its subsidiaries ("ST") reserve the right to make changes, corrections, modifications or improvements, to this document, and the products and services described herein at any time, without notice.

All ST products are sold pursuant to ST's terms and conditions of sale.

Purchasers are solely responsible for the choice, selection and use of the ST products and services described herein, and ST assumes no liability whatsoever relating to the choice, selection or use of the ST products and services described herein.

No license, express or implied, by estoppel or otherwise, to any intellectual property rights is granted under this document. If any part of this document refers to any third party products or services it shall not be deemed a license grant by ST for the use of such third party products or services, or any intellectual property contained therein or considered as a warranty covering the use in any manner whatsoever of such third party products or services or any intellectual property contained therein.

UNLESS OTHERWISE SET FORTH IN ST'S TERMS AND CONDITIONS OF SALE ST DISCLAIMS ANY EXPRESS OR IMPLIED WARRANTY WITH RESPECT TO THE USE AND/OR SALE OF ST PRODUCTS INCLUDING WITHOUT LIMITATION IMPLIED WARRANTIES OF MERCHANTABILITY, FITNESS FOR A PARTICULAR PURPOSE (AND THEIR EQUIVALENTS UNDER THE LAWS OF ANY JURISDICTION), OR INFRINGEMENT OF ANY PATENT, COPYRIGHT OR OTHER INTELLECTUAL PROPERTY RIGHT.

ST PRODUCTS ARE NOT DESIGNED OR AUTHORIZED FOR USE IN: (A) SAFETY CRITICAL APPLICATIONS SUCH AS LIFE SUPPORTING, ACTIVE IMPLANTED DEVICES OR SYSTEMS WITH PRODUCT FUNCTIONAL SAFETY REQUIREMENTS; (B) AERONAUTIC APPLICATIONS; (C) AUTOMOTIVE APPLICATIONS OR ENVIRONMENTS, AND/OR (D) AEROSPACE APPLICATIONS OR ENVIRONMENTS. WHERE ST PRODUCTS ARE NOT DESIGNED FOR SUCH USE, THE PURCHASER SHALL USE PRODUCTS AT PURCHASER'S SOLE RISK, EVEN IF ST HAS BEEN INFORMED IN WRITING OF SUCH USAGE, UNLESS A PRODUCT IS EXPRESSLY DESIGNATED BY ST AS BEING INTENDED FOR "AUTOMOTIVE, AUTOMOTIVE SAFETY OR MEDICAL" INDUSTRY DOMAINS ACCORDING TO ST PRODUCT DESIGN SPECIFICATIONS. PRODUCTS FORMALLY ESCC, QML OR JAN QUALIFIED ARE DEEMED SUITABLE FOR USE IN AEROSPACE BY THE CORRESPONDING GOVERNMENTAL AGENCY.

Resale of ST products with provisions different from the statements and/or technical features set forth in this document shall immediately void any warranty granted by ST for the ST product or service described herein and shall not create or extend in any manner whatsoever, any liability of ST.

ST and the ST logo are trademarks or registered trademarks of ST in various countries.

Information in this document supersedes and replaces all information previously supplied.

The ST logo is a registered trademark of STMicroelectronics. All other names are the property of their respective owners.

© 2013 STMicroelectronics - All rights reserved

STMicroelectronics group of companies

Australia - Belgium - Brazil - Canada - China - Czech Republic - Finland - France - Germany - Hong Kong - India - Israel - Italy - Japan - Malaysia - Malta - Morocco - Philippines - Singapore - Spain - Sweden - Switzerland - United Kingdom - United States of America

www.st.com