

R74 Series 125°C Single Metallized Polypropylene Film, Radial, AC Applications (Automotive Grade)

Overview

The R74 Series 125°C is constructed of metallized polypropylene film with radial leads of tinned wire. The radial leads are electrically welded to the metal layer on the ends of the capacitor winding. The capacitor is encapsulated in a self-extinguishing solvent resistant plastic case with thermosetting resin material meeting the UL 94V-0 requirements. Two different winding constructions are used depending on voltage parameters. Please see the Performance Characteristics for more information.

Automotive grade devices are available and meet the demanding Automotive Electronics Council's AEC-Q200 qualification requirements.

Applications

Typical applications include electronic lighting such as automotive headlamps and ballasts, as well as pulse applications with high AC voltage and high current. Not suitable for across-the-line application (see Suppressor Capacitors).

Benefits

- Voltage range: 500 – 700 VAC
- Capacitance range: 470 pF – 0.018 μ F
- Lead Spacing: 10.0 – 22.5 mm
- Capacitance tolerance: \pm 5%, \pm 10%
- Climatic category: 55/125/56 IEC 60068-1
- Operating temperature range of -55°C to $+125^{\circ}\text{C}$
- RoHS compliance and lead-free terminations
- Tape and reel packaging in accordance with IEC 60286-2
- Self-healing
- Automotive (AEC-Q200) grades available

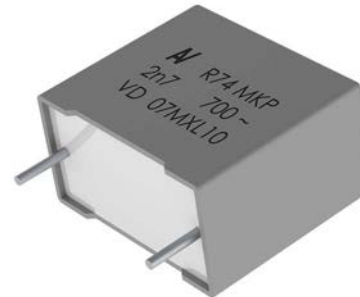

Part Number System

R74	5	F	1100	AA	H0	J
Series	Rated Voltage (VAC)	Lead Spacing (mm)	Capacitance Code (pF)	Packaging	Internal Use	Capacitance Tolerance
Metallized Polypropylene	5 = 500 7 = 700	F = 10 I = 15 N = 22.5	The last three digits represent significant figures. The first digit specifies the total number of zeros to be added.	See Ordering Options Table	H0 H1 H3 (Hx = 125°C)	J = \pm 5% K = \pm 10%

Ordering Options Table

Lead Spacing Nominal (mm)	Type of Leads and Packaging	Lead Length (mm)	Lead and Packaging Code
10 15 22.5	Standard Lead and Packaging Options		
	Bulk (Bag) – Short Leads	4 +2/-0	AA
	Ammo Pack	$H_0 = 18.5 \pm 0.5$	DQ
	Other Lead and Packaging Options		
	Tape & Reel (Standard Reel)	$H_0 = 18.5 \pm 0.5$	GY
	Tape & Reel (Large Reel)	$H_0 = 18.5 \pm 0.5$	CK
	Bulk (Bag)–Short Leads	3.5 +0.5/-0	JB
	Bulk (Bag)–Short Leads	4.0 +0.5/-0	JE
	Bulk (Bag)–Short Leads	3.2 +0.3/-0.2	JH
	Bulk (Bag)–Long Leads	18 +1/-1	JM
Bulk (Bag)–Long Leads	30 +5/-0	40	
Bulk (Bag)–Long Leads	25 +2/-1	50	

Dimensions – Millimeters

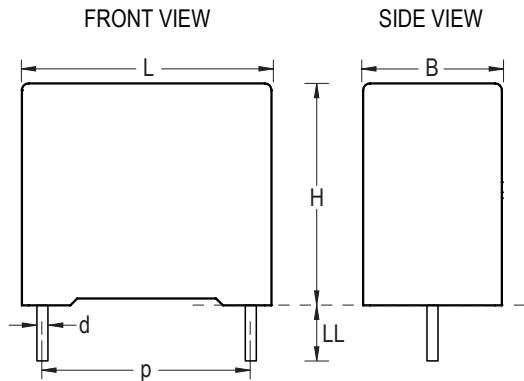

p		B		H		L		d	
Nominal	Tolerance	Nominal	Tolerance	Nominal	Tolerance	Nominal	Tolerance	Nominal	Tolerance
10.0	+/- 0.4	4.0	+0.2	9.0	+0.1	13.0	+0.2	0.6	+/- 0.05
10.0	+/- 0.4	5.0	+0.2	11.0	+0.1	13.0	+0.2	0.6	+/- 0.05
10.0	+/- 0.4	6.0	+0.2	12.0	+0.1	13.0	+0.2	0.6	+/- 0.05
15.0	+/- 0.4	4.0	+0.2	10.0	+0.1	18.0	+0.3	0.8	+/- 0.05
15.0	+/- 0.4	5.0	+0.2	11.0	+0.1	18.0	+0.3	0.8	+/- 0.05
15.0	+/- 0.4	6.0	+0.2	12.0	+0.1	18.0	+0.3	0.8	+/- 0.05
15.0	+/- 0.4	7.5	+0.2	13.5	+0.1	18.0	+0.5	0.8	+/- 0.05
15.0	+/- 0.4	8.5	+0.2	14.5	+0.1	18.0	+0.5	0.8	+/- 0.05
15.0	+/- 0.4	9.0	+0.2	12.5	+0.1	18.0	+0.5	0.8	+/- 0.05
15.0	+/- 0.4	10.0	+0.2	16.0	+0.1	18.0	+0.5	0.8	+/- 0.05
15.0	+/- 0.4	11.0	+0.2	19.0	+0.1	18.0	+0.5	0.8	+/- 0.05
15.0	+/- 0.4	13.0	+0.2	12.0	+0.1	18.0	+0.5	0.8	+/- 0.05
22.5	+/- 0.4	6.0	+0.2	15.0	+0.1	26.5	+0.3	0.8	+/- 0.05
22.5	+/- 0.4	7.0	+0.2	16.0	+0.1	26.5	+0.3	0.8	+/- 0.05
22.5	+/- 0.4	8.5	+0.2	17.0	+0.1	26.5	+0.3	0.8	+/- 0.05
22.5	+/- 0.4	10.0	+0.2	18.5	+0.1	26.5	+0.3	0.8	+/- 0.05
22.5	+/- 0.4	11.0	+0.2	20.0	+0.1	26.5	+0.3	0.8	+/- 0.05
22.5	+/- 0.4	13.0	+0.2	22.0	+0.1	26.5	+0.3	0.8	+/- 0.05

Note: See Ordering Options Table for lead length (LL/Ho) options.

Performance Characteristics

Dielectric	Polypropylene film	
Plates	Metal layer deposited by evaporation under vacuum	
Winding	Non-inductive type	
Leads	Tinned wire	
Protection	Plastic case, thermosetting resin filled. Box material is solvent resistant and flame retardant according to UL94.	
Related Documents	IEC 60384-16, IEC 60384-17	
Sections	2	3
Voltage Range (VAC)	500	700
Voltage Range (VDC)	1600	2000
Capacitance Range (µF)	0.001 – 0.1	0.00068 – 0.068
Capacitance Values	E12 series (IEC 60063) measured @ 1 kHz and +20 ±1°C	
Capacitance Tolerance	±5%, ±10%	
Category Temperature Range	-55°C to +125°C	
Rated Temperature T _R	+105°C	
Voltage Derating	Above +105°C DC and AC voltage derating is 1.25%/°C	
Climatic Category	55/125/56 IEC 60068-1	
Storage Conditions	Storage time: ≤ 24 months from the date marked on the label package	
	Average relative humidity per year ≤ 70%	
	RH ≤ 85% for 30 days randomly distributed throughout the year	
	Dew is absent	
	Temperature: -40 to 80°C (see "Maximum Humidity in Storage Conditions" graph below)	

Maximum Humidity in Storage Conditions

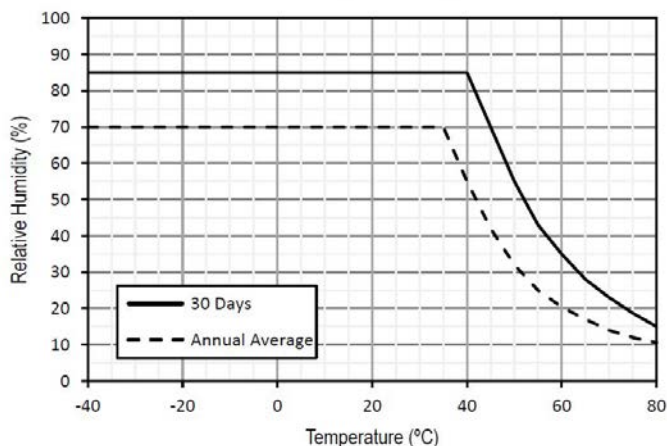

Performance Characteristics cont'd

Test Voltage	1.6 x V _R VDC for 2 seconds (between terminations) @ +25°C ±5°C			
Capacitance Drift	Maximum 1% after a 2 year storage period at a temperature of +10°C to +40°C and a relative humidity of 40% to 60%			
Maximum Pulse Steepness	dV/dt according to Table 1. For peak to peak voltages lower than rated voltage (V _{pp} <V _R), the specified dv/dt can be multiplied by the factor V _R /V _{pp}			
Temperature Coefficient	-(200 ±100) ppm/°C at 1 kHz			
Self Inductance (Lead Length ~ 2 mm)	Lead Spacing (mm)	10	15	22.5
	L (nH) ≈	9	10	18
	Maximum 1 nH per 1 mm lead and capacitor length.			
Dissipation Factor tanδ	Measured at 25°C ± 5°C			
	Frequency	C ≤ 2.2 nF	2.2 nF < C ≤ 0.027 μF	0.027 μF < C ≤ 0.1 μF
	1 kHz	0.01%	0.01%	0.04%
	10 kHz	0.02%	0.02%	0.06%
	100 kHz	0.03%	0.08%	0.25%
Insulation Resistance	Measured @ +25°C ±5°C, 100 VDC 60 seconds			
	Minimum Values Between Terminals			
	All Capacitance Values			
	≥ 100,000 MΩ			

Qualification

Automotive Grade products meet or exceed the requirements outlined by the Automotive Electronics Council. Details regarding test methods and conditions are referenced in document AEC-Q200, Stress Test Qualification for Passive Components. For additional information regarding the Automotive Electronics Council and AEC-Q200, please visit their website at www.aecouncil.com.

Maximum Voltage (V_{rms}) vs. Frequency (Sinusoidal Waveform/Th ≤ 85°C)

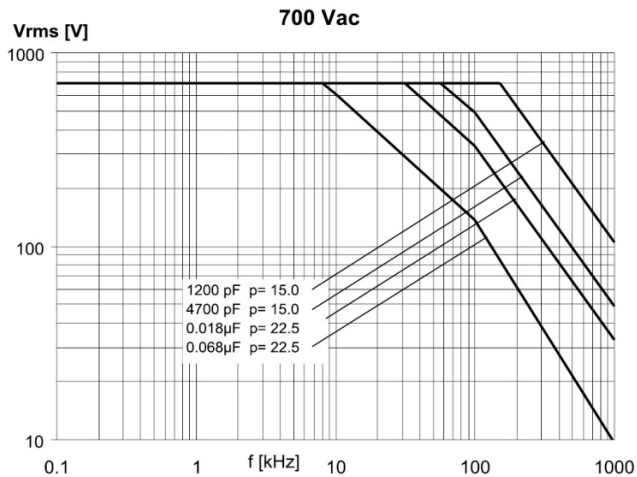
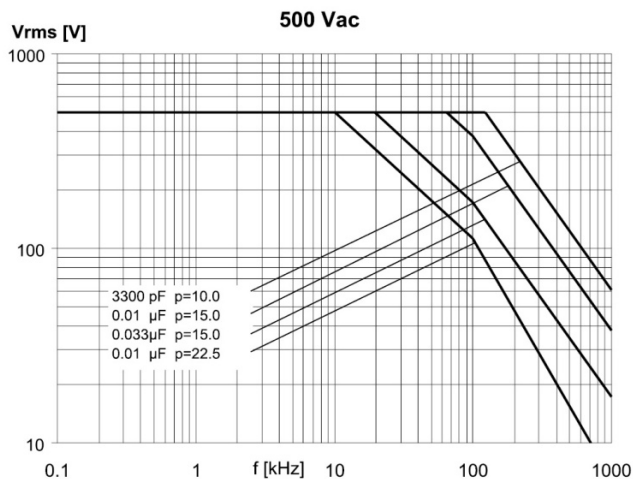

Maximum Current (I_{rms}) vs. Frequency (Sinusoidal Waveform/Th ≤ 85°C)

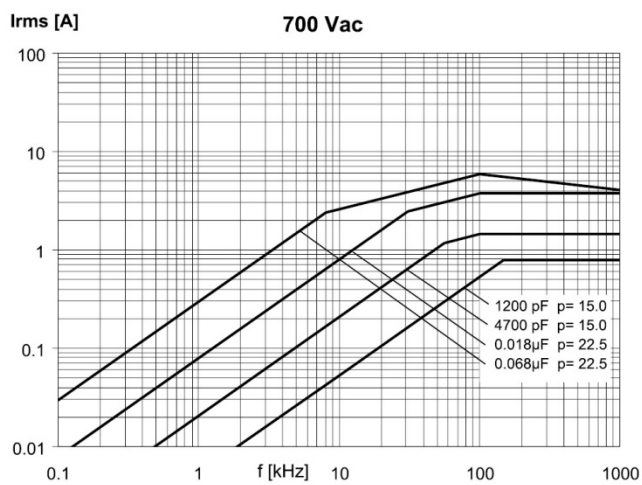
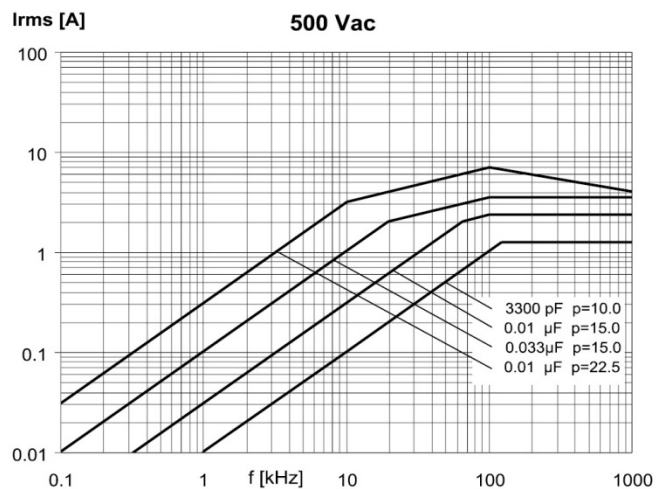

Environmental Test Data

Damp Heat, Steady State Test	Test Conditions:		Performances
	Temperature: Relative humidity (RH): Test duration:	+40°C ±2°C 93% ±2% 56 days	$ \Delta C/C \leq 2\%$, $\Delta \tan\delta \leq 0.001 @ 1 \text{ kHz}$ IR after test $\geq 50\%$ of initial limit
Endurance Test	Test Conditions		Performances
Test 1st	Temperature: Voltage applied: Test duration:	+125°C +0/-2°C 0.94 x V _R (AC) @ 50Hz 2,000 hours	$ \Delta C/C \leq 5\%$, $\Delta \tan\delta \leq 0.0015 @ 1 \text{ kHz}$ IR after test $\geq 50\%$ of initial limit
Test 2nd	Temperature: Voltage applied: Test duration:	+105°C ±2°C 1.25 x V _R (AC) @ 50Hz 2,000 hours	
Resistance to Soldering Heat Test	Test Conditions		Performances
	Solder bath temperature: Dipping time (with heat screen):	260°C ±5°C 10 seconds ±1 second	$ \Delta C/C \leq 1\%$, $\Delta \tan\delta \leq 0.001 @ 1 \text{ kHz}$ IR after test \geq initial limit

Environmental Compliance

All KEMET pulse capacitors are RoHS Compliant.

Table 1 – Ratings & Part Number Reference

VAC	VDC	Capacitance Value (µF)	Dimensions in mm			Lead Spacing (p)	dV/dt (V/µs)	Max K ₀ (V ² /µs)	New KEMET Part Number	Legacy Part Number
			B	H	L					
500	1,600	0.0010	4.0	9.0	13.0	10.0	6,000	19,200,000	745F1100(1)H0(2)	R745F1100(1)H0(2)
500	1,600	0.0012	4.0	9.0	13.0	10.0	6,000	19,200,000	745F1120(1)H0(2)	R745F1120(1)H0(2)
500	1,600	0.0015	4.0	9.0	13.0	10.0	6,000	19,200,000	745F1150(1)H0(2)	R745F1150(1)H0(2)
500	1,600	0.0018	5.0	11.0	13.0	10.0	6,000	19,200,000	745F1180(1)H0(2)	R745F1180(1)H0(2)
500	1,600	0.0022	5.0	11.0	13.0	10.0	6,000	19,200,000	745F1220(1)H0(2)	R745F1220(1)H0(2)
500	1,600	0.0027	5.0	11.0	13.0	10.0	6,000	19,200,000	745F1270(1)H0(2)	R745F1270(1)H0(2)
500	1,600	0.0033	6.0	12.0	13.0	10.0	6,000	19,200,000	745F1330(1)H0(2)	R745F1330(1)H0(2)
500	1,600	0.0039	6.0	12.0	13.0	10.0	6,000	19,200,000	745F1390(1)H0(2)	R745F1390(1)H0(2)
500	1,600	0.0027	4.0	10.0	18.0	15.0	4,500	14,400,000	745I1270(1)H3(2)	R745I1270(1)H3(2)
500	1,600	0.0033	4.0	10.0	18.0	15.0	4,500	14,400,000	745I1330(1)H3(2)	R745I1330(1)H3(2)
500	1,600	0.0039	4.0	10.0	18.0	15.0	4,500	14,400,000	745I1390(1)H3(2)	R745I1390(1)H3(2)
500	1,600	0.0047	5.0	11.0	18.0	15.0	4,500	14,400,000	745I1470(1)H0(2)	R745I1470(1)H0(2)
500	1,600	0.0056	5.0	11.0	18.0	15.0	4,500	14,400,000	745I1560(1)H0(2)	R745I1560(1)H0(2)
500	1,600	0.0068	6.0	12.0	18.0	15.0	4,500	14,400,000	745I1680(1)H0(2)	R745I1680(1)H0(2)
500	1,600	0.0082	6.0	12.0	18.0	15.0	4,500	14,400,000	745I1820(1)H0(2)	R745I1820(1)H0(2)
500	1,600	0.010	6.0	12.0	18.0	15.0	4,500	14,400,000	745I2100(1)H0(2)	R745I2100(1)H0(2)
500	1,600	0.012	7.5	13.5	18.0	15.0	4,500	14,400,000	745I2120(1)H0(2)	R745I2120(1)H0(2)
500	1,600	0.015	7.5	13.5	18.0	15.0	4,500	14,400,000	745I2150(1)H0(2)	R745I2150(1)H0(2)
500	1,600	0.015	13.0	12.0	18.0	15.0	4,500	14,400,000	745I2150(1)H1(2)	R745I2150(1)H1(2)
500	1,600	0.018	8.5	14.5	18.0	15.0	4,500	14,400,000	745I2180(1)H0(2)	R745I2180(1)H0(2)
500	1,600	0.018	13.0	12.0	18.0	15.0	4,500	14,400,000	745I2180(1)H1(2)	R745I2180(1)H1(2)
500	1,600	0.022	10.0	16.0	18.0	15.0	4,500	14,400,000	745I2220(1)H0(2)	R745I2220(1)H0(2)
500	1,600	0.022	13.0	12.0	18.0	15.0	4,500	14,400,000	745I2220(1)H1(2)	R745I2220(1)H1(2)
500	1,600	0.027	10.0	16.0	18.0	15.0	4,500	14,400,000	745I2270(1)H0(2)	R745I2270(1)H0(2)
500	1,600	0.033	11.0	19.0	18.0	15.0	4,500	14,400,000	745I2330(1)H0(2)	R745I2330(1)H0(2)
500	1,600	0.018	6.0	15.0	26.5	22.5	1,200	3,840,000	745N2180(1)H0(2)	R745N2180(1)H0(2)
500	1,600	0.022	6.0	15.0	26.5	22.5	1,200	3,840,000	745N2220(1)H0(2)	R745N2220(1)H0(2)
500	1,600	0.027	7.0	16.0	26.5	22.5	1,200	3,840,000	745N2270(1)H0(2)	R745N2270(1)H0(2)
500	1,600	0.033	7.0	16.0	26.5	22.5	1,200	3,840,000	745N2330(1)H0(2)	R745N2330(1)H0(2)
500	1,600	0.039	8.5	17.0	26.5	22.5	1,200	3,840,000	745N2390(1)H0(2)	R745N2390(1)H0(2)
500	1,600	0.047	10.0	18.5	26.5	22.5	1,200	3,840,000	745N2470(1)H0(2)	R745N2470(1)H0(2)
500	1,600	0.056	10.0	18.5	26.5	22.5	1,200	3,840,000	745N2560(1)H0(2)	R745N2560(1)H0(2)
500	1,600	0.068	11.0	20.0	26.5	22.5	1,200	3,840,000	745N2680(1)H0(2)	R745N2680(1)H0(2)
500	1,600	0.082	13.0	22.0	26.5	22.5	1,200	3,840,000	745N2820(1)H0(2)	R745N2820(1)H0(2)
500	1,600	0.10	13.0	22.0	26.5	22.5	1,200	3,840,000	745N3100(1)H0(2)	R745N3100(1)H0(2)
700	2,000	0.00068	4.0	10.0	18.0	15.0	9,500	38,000,000	747I0680(1)H3(2)	R747I0680(1)H3(2)
700	2,000	0.00082	4.0	10.0	18.0	15.0	9,500	38,000,000	747I0820(1)H3(2)	R747I0820(1)H3(2)
700	2,000	0.0010	4.0	10.0	18.0	15.0	9,500	38,000,000	747I1100(1)H3(2)	R747I1100(1)H3(2)
700	2,000	0.0012	4.0	10.0	18.0	15.0	9,500	38,000,000	747I1120(1)H3(2)	R747I1120(1)H3(2)
700	2,000	0.0013	4.0	10.0	18.0	15.0	9,500	38,000,000	747I1130(1)H3(2)	R747I1130(1)H3(2)
700	2,000	0.0018	4.0	10.0	18.0	15.0	9,500	38,000,000	747I1180(1)H3(2)	R747I1180(1)H3(2)
700	2,000	0.0022	4.0	10.0	18.0	15.0	9,500	38,000,000	747I1220(1)H3(2)	R747I1220(1)H3(2)
700	2,000	0.0025	4.0	10.0	18.0	15.0	9,500	38,000,000	747I1250(1)H3(2)	R747I1250(1)H3(2)
700	2,000	0.0027	5.0	11.0	18.0	15.0	9,500	38,000,000	747I1270(1)H0(2)	R747I1270(1)H0(2)
700	2,000	0.0033	5.0	11.0	18.0	15.0	9,500	38,000,000	747I1330(1)H0(2)	R747I1330(1)H0(2)
700	2,000	0.0036	6.0	12.0	18.0	15.0	9,500	38,000,000	747I1360(1)H0(2)	R747I1360(1)H0(2)
700	2,000	0.0039	6.0	12.0	18.0	15.0	9,500	38,000,000	747I1390(1)H0(2)	R747I1390(1)H0(2)
700	2,000	0.0043	6.0	12.0	18.0	15.0	9,500	38,000,000	747I1430(1)H0(2)	R747I1430(1)H0(2)
700	2,000	0.0047	6.0	12.0	18.0	15.0	9,500	38,000,000	747I1470(1)H0(2)	R747I1470(1)H0(2)
700	2,000	0.0052	6.0	12.0	18.0	15.0	9,500	38,000,000	747I1520(1)H0(2)	R747I1520(1)H0(2)
700	2,000	0.0056	6.0	12.0	18.0	15.0	9,500	38,000,000	747I1560(1)H0(2)	R747I1560(1)H0(2)
700	2,000	0.0062	7.5	13.5	18.0	15.0	9,500	38,000,000	747I1620(1)H0(2)	R747I1620(1)H0(2)
700	2,000	0.0068	7.5	13.5	18.0	15.0	9,500	38,000,000	747I1680(1)H0(2)	R747I1680(1)H0(2)
700	2,000	0.0082	7.5	13.5	18.0	15.0	9,500	38,000,000	747I1820(1)H0(2)	R747I1820(1)H0(2)
700	2,000	0.0082	9.0	12.5	18.0	15.0	9,500	38,000,000	747I1820(1)H1(2)	R747I1820(1)H1(2)
700	2,000	0.010	8.5	14.5	18.0	15.0	9,500	38,000,000	747I2100(1)H0(2)	R747I2100(1)H0(2)
700	2,000	0.010	13.0	12.0	18.0	15.0	9,500	38,000,000	747I2100(1)H1(2)	R747I2100(1)H1(2)
700	2,000	0.012	10.0	16.0	18.0	15.0	9,500	38,000,000	747I2120(1)H0(2)	R747I2120(1)H0(2)
700	2,000	0.012	13.0	12.0	18.0	15.0	9,500	38,000,000	747I2120(1)H1(2)	R747I2120(1)H1(2)
700	2,000	0.015	10.0	16.0	18.0	15.0	9,500	38,000,000	747I2150(1)H0(2)	R747I2150(1)H0(2)
VAC	VDC	Capacitance Value (µF)	B (mm)	H (mm)	L (mm)	Lead Spacing (p)	dV/dt (V/µs)	Max K ₀ (V ² /µs)	New KEMET Part Number	Legacy Part Number

(1) Insert lead and packaging code. See Ordering Options Table for available options.

(2) J = 5%, K = 10%.

Table 1 – Ratings & Part Number Reference cont'd

VAC	VDC	Capacitance Value (μF)	Dimensions in mm			Lead Spacing (p)	dV/dt (V/μs)	Max K ₀ (V ² /μs)	New KEMET Part Number	Legacy Part Number
			B	H	L					
700	2,000	0.018	11.0	19.0	18.0	15.0	9,500	38,000,000	747I2180(1)H0(2)	R747I2180(1)H0(2)
700	2,000	0.0062	6.0	15.0	26.5	22.5	4,500	18,000,000	747N1620(1)H0(2)	R747N1620(1)H0(2)
700	2,000	0.0068	6.0	15.0	26.5	22.5	4,500	18,000,000	747N1680(1)H0(2)	R747N1680(1)H0(2)
700	2,000	0.0075	6.0	15.0	26.5	22.5	4,500	18,000,000	747N1750(1)H0(2)	R747N1750(1)H0(2)
700	2,000	0.0082	6.0	15.0	26.5	22.5	4,500	18,000,000	747N1820(1)H0(2)	R747N1820(1)H0(2)
700	2,000	0.010	6.0	15.0	26.5	22.5	4,500	18,000,000	747N2100(1)H0(2)	R747N2100(1)H0(2)
700	2,000	0.012	6.0	15.0	26.5	22.5	4,500	18,000,000	747N2120(1)H0(2)	R747N2120(1)H0(2)
700	2,000	0.015	6.0	15.0	26.5	22.5	4,500	18,000,000	747N2150(1)H0(2)	R747N2150(1)H0(2)
700	2,000	0.018	7.0	16.0	26.5	22.5	4,500	18,000,000	747N2180(1)H0(2)	R747N2180(1)H0(2)
700	2,000	0.022	8.5	17.0	26.5	22.5	4,500	18,000,000	747N2220(1)H0(2)	R747N2220(1)H0(2)
700	2,000	0.027	8.5	17.0	26.5	22.5	4,500	18,000,000	747N2270(1)H0(2)	R747N2270(1)H0(2)
700	2,000	0.033	10.0	18.5	26.5	22.5	4,500	18,000,000	747N2330(1)H0(2)	R747N2330(1)H0(2)
700	2,000	0.039	10.0	18.5	26.5	22.5	4,500	18,000,000	747N2390(1)H0(2)	R747N2390(1)H0(2)
700	2,000	0.047	11.0	20.0	26.5	22.5	4,500	18,000,000	747N2470(1)H0(2)	R747N2470(1)H0(2)
700	2,000	0.056	13.0	22.0	26.5	22.5	4,500	18,000,000	747N2560(1)H0(2)	R747N2560(1)H0(2)
700	2,000	0.062	13.0	22.0	26.5	22.5	4,500	18,000,000	747N2620(1)H0(2)	R747N2620(1)H0(2)
700	2,000	0.068	13.0	22.0	26.5	22.5	4,500	18,000,000	747N2680(1)H0(2)	R747N2680(1)H0(2)
VAC	VDC	Capacitance Value (μF)	B (mm)	H (mm)	L (mm)	Lead Spacing (p)	dV/dt (V/μs)	Max K ₀ (V ² /μs)	New KEMET Part Number	Legacy Part Number

(1) Insert lead and packaging code. See Ordering Options Table for available options.

(2) J = 5%, K = 10%.

Soldering Process

The implementation of the RoHS directive has resulted in the selection of SnAgCu (SAC) alloys or SnCu alloys as primary solder. This has increased the liquidus temperature from that of 183°C for SnPb eutectic alloy to 217 – 221°C for the new alloys. As a result, the heat stress to the components, even in wave soldering, has increased considerably due to higher pre-heat and wave temperatures. Polypropylene capacitors are especially sensitive to heat (the melting point of polypropylene is 160 – 170°C). Wave soldering can be destructive, especially for mechanically small polypropylene capacitors (with lead spacing of 5 mm to 15 mm), and great care has to be taken during soldering. The recommended solder profiles from KEMET should be used. Please consult KEMET with any questions. In general, the wave soldering curve from IEC Publication 61760-1 Edition 2 serves as a solid guideline for successful soldering. Please see Figure 1.

Reflow soldering is not recommended for through-hole film capacitors. Exposing capacitors to a soldering profile in excess of the above the recommended limits may result to degradation or permanent damage to the capacitors.

Do not place the polypropylene capacitor through an adhesive curing oven to cure resin for surface mount components. Insert through-hole parts after the curing of surface mount parts. Consult KEMET to discuss the actual temperature profile in the oven, if through-hole components must pass through the adhesive curing process. A maximum two soldering cycles is recommended. Please allow time for the capacitor surface temperature to return to a normal temperature before the second soldering cycle.

Manual Soldering Recommendations

Following is the recommendation for manual soldering with a soldering iron.

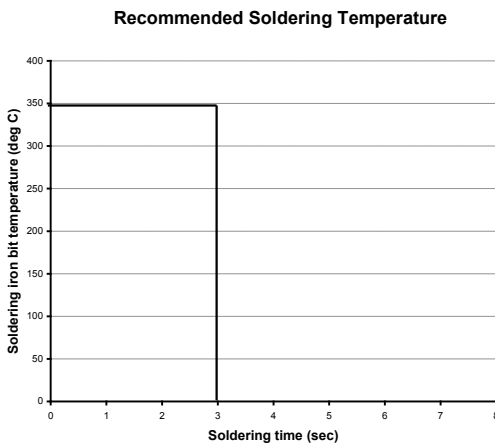

The soldering iron tip temperature should be set at 350°C (+10°C maximum) with the soldering duration not to exceed more than 3 seconds.

Wave Soldering Recommendations

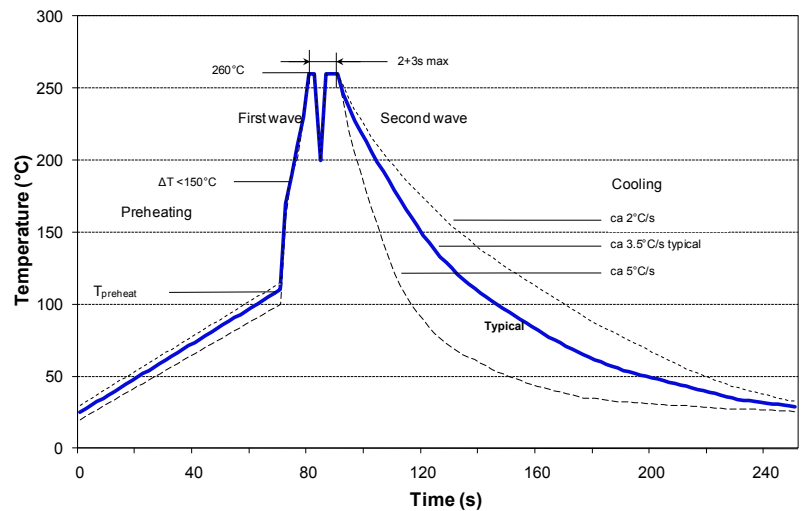

Soldering Process cont'd

Wave Soldering Recommendations cont'd

1. The table indicates the maximum set-up temperature of the soldering process

Figure 1

Dielectric Film Material	Maximum Preheat Temperature			Maximum Peak Soldering Temperature	
	Capacitor Pitch ≤ 10 mm	Capacitor Pitch = 15 mm	Capacitor Pitch > 15 mm	Capacitor Pitch ≤ 15 mm	Capacitor Pitch > 15 mm
Polyester	130°C	130°C	130°C	270°C	270°C
Polypropylene	100°C	110°C	130°C	260°C	270°C
Paper	130°C	130°C	140°C	270°C	270°C
Polyphenylene Sulphide	150°C	150°C	160°C	270°C	270°C

2. The maximum temperature measured inside the capacitor:

Set the temperature so that inside the element the maximum temperature is below the limit:

Dielectric Film Material	Maximum temperature measured inside the element
Polyester	160°C
Polypropylene	110°C
Paper	160°C
Polyphenylene sulphide	160°C

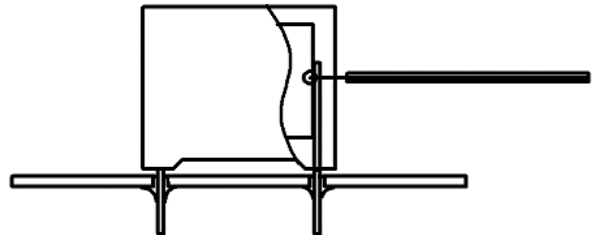

Temperature monitored inside the capacitor.

Selective Soldering Recommendations

Selective dip soldering is a variation of reflow soldering. In this method, the printed circuit board with through-hole components to be soldered is preheated and transported over the solder bath as in normal flow soldering without touching the solder. When the board is over the bath, it is stopped and pre-designed solder pots are lifted from the bath with molten solder only at the places of the selected components, and pressed against the lower surface of the board to solder the components.

The temperature profile for selective soldering is similar to the double wave flow soldering outlined in this document, **however, instead of two baths, there is only one bath with a time from 3 to 10 seconds.** In selective soldering, the risk of overheating is greater than in double wave flow soldering, and great care must be taken so that the parts are not overheated.

Construction

2 Sections

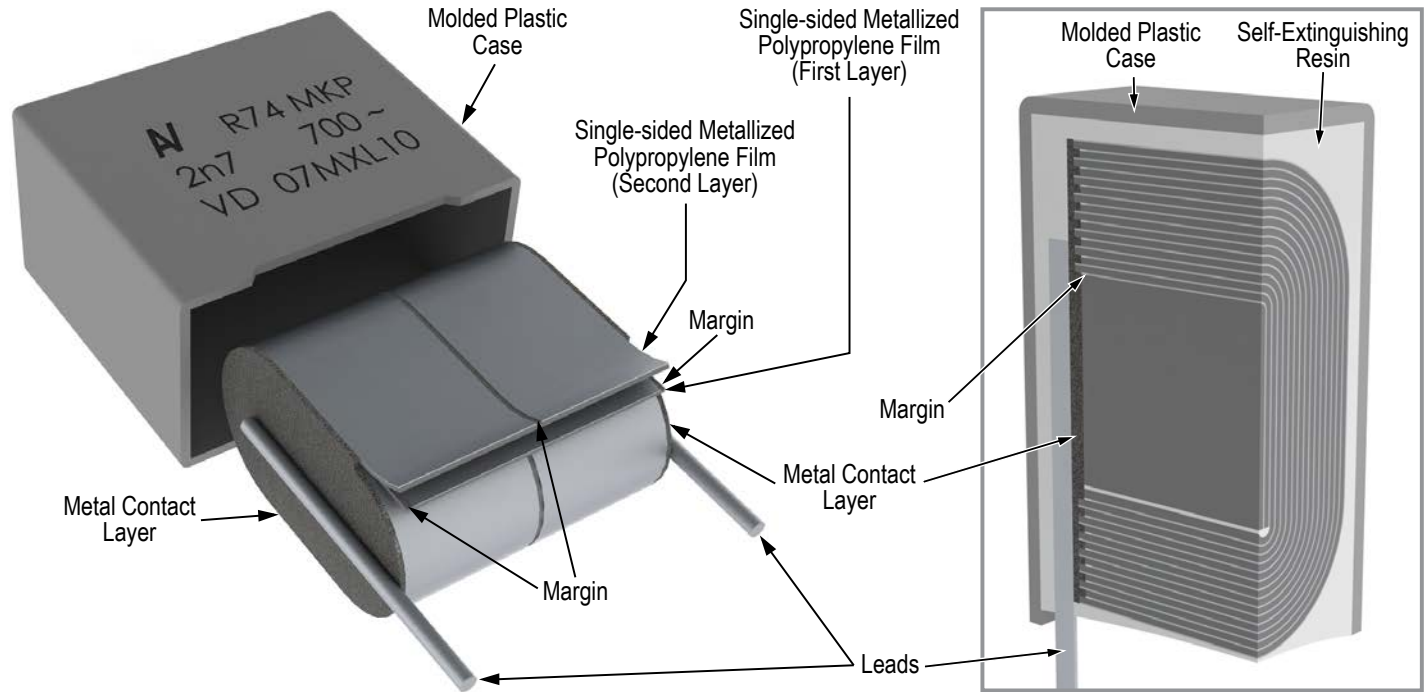

Winding Schemes

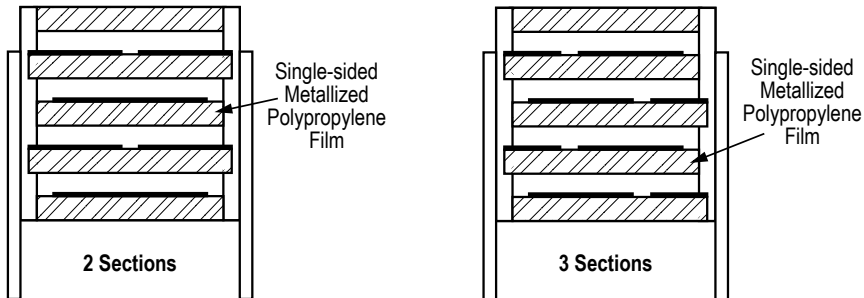

Marking

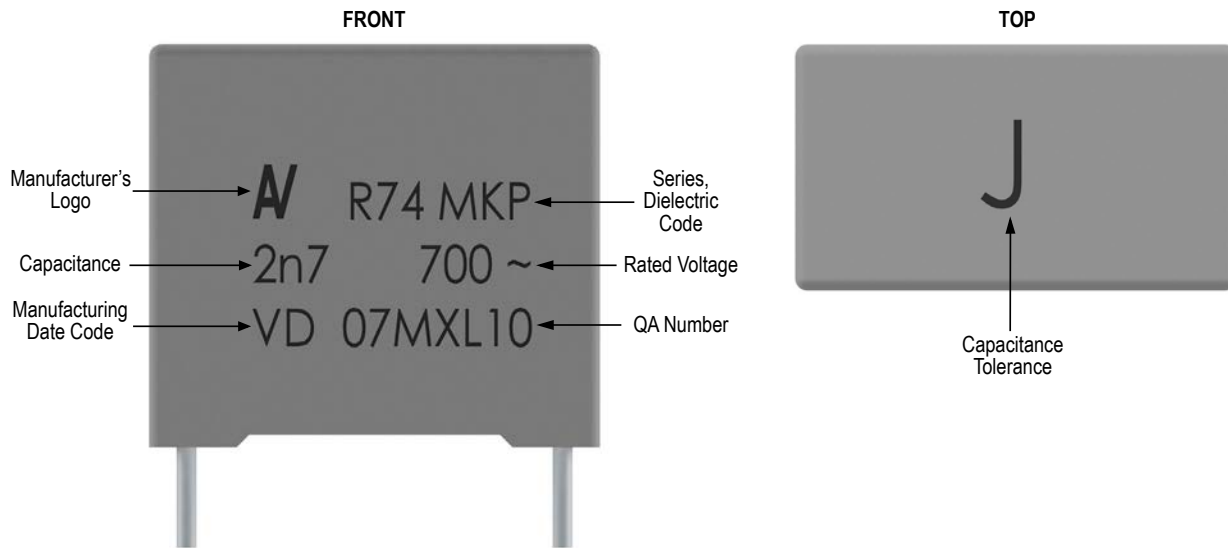

Packaging Quantities

Lead Spacing	Thickness (mm)	Height (mm)	Length (mm)	Bulk Short Leads	Bulk Long Leads	Standard Reel ø 355 mm	Large Reel ø 500 mm	Ammo Taped
10	4.0	9.0	13.0	2,000	1,800	750	1,500	1,000
	5.0	11.0	13.0	1,300	1,500	600	1,250	800
	6.0	12.0	13.0	1,000	1,200	500	1,000	680
15	4.0	10.0	18.0	2,500	1,500	-	1,500	1,000
	5.0	11.0	18.0	2,000	1,000	600	1,250	800
	6.0	12.0	18.0	1,750	900	500	1,000	680
	7.5	13.5	18.0	1,000	700	350	800	500
	8.5	14.5	18.0	1,000	500	300	700	440
	9.0	12.5	18.0	1,000	520	270	650	410
	10.0	16.0	18.0	750	500	300	600	380
	11.0	19.0	18.0	450	350	-	500	340
22.5	6.0	15.0	26.5	805	500		700	464
	7.0	16.0	26.5	700	500		550	380
	8.5	17.0	26.5	468	300		450	280
	10.0	18.5	26.5	396	300		350	235
	11.0	20.0	26.5	360	250		350	217
	13.0	22.0	26.5	300	200		300	-

Lead Taping & Packaging (IEC 60286–2)

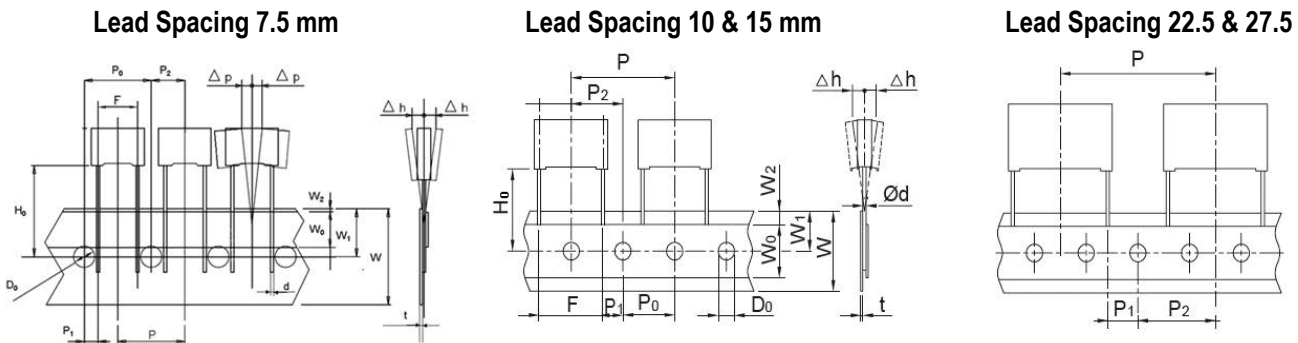

Taping Specification

Description	Symbol	Dimensions (mm)				Tolerance
		Lead Spacing				
		10.0	15.0	22.5		
Lead wire diameter	d	0.6	0.6 - 0.8	0.8	±0.05	
Taping lead space	P	25.4	25.4	38.1	±1	
Feed hole lead space *	P ₀	12.7	12.7	12.7	±0.2 **	
Centering of the lead wire	P ₁	7.7	5.2	7.8	±0.7	
Centering of the body	P ₂	12.7	12.7	19.05	±1.3	
Lead spacing ***	F	10.0	15.0	22.5	+0.6/-0.1	
Component alignment	Δh	0	0	0	±2	
Component deviation	Δp	0	0	0	±1	
Height of component from tape center	H ₀ ****	18.5	18.5	18.5	±0.5	
Carrier tape width	W	18	18	18	+1/-0.5	
Hold down tape width	W ₀	9	10	10	Minimum	
Hole position	W ₁	9	9	9	±0.5	
Hold down tape position	W ₂	3	3	3	Maximum	
Feed hole diameter	D ₀	4	4	4	±0.2	
Tape thickness	t	0.7	0.7	0.7	±0.2	

* Available also 15 mm.

** Maximum 1 mm on 20 lead spacing.

*** 15 mm and 10 mm taped to 7.5 mm (crimped leads) available upon request.

**** H₀ = 16.5 mm is available upon request.

Lead Taping & Packaging (IEC 60286–2) cont'd

Ammo Specifications

Dimensions (mm)		
H	W	T
360	340	59

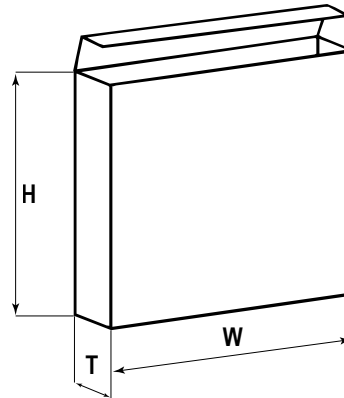

Reel Specifications

Dimensions (mm)		
D	H	W
355	30	55 Maximum
500	25	

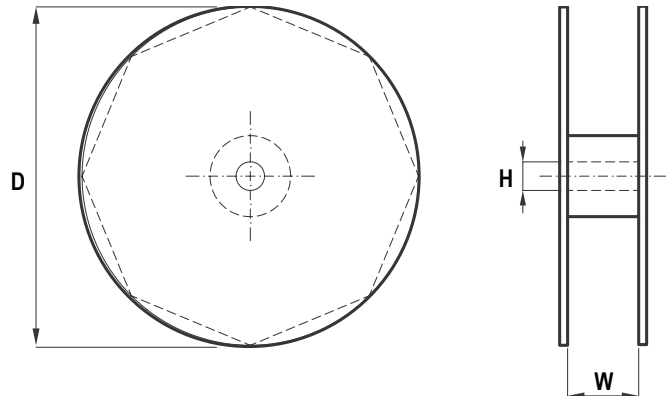

Manufacturing Date Code (IEC–60062)

Y = Year, Z = Month			
Year	Code	Month	Code
2000	M	January	1
2001	N	February	2
2002	P	March	3
2003	R	April	4
2004	S	May	5
2005	T	June	6
2006	U	July	7
2007	V	August	8
2008	W	September	9
2009	X	October	0
2010	A	November	N
2011	B	December	D
2012	C		
2013	D		
2014	E		
2015	F		
2016	H		
2017	J		
2018	K		
2019	L		
2020	M		

KEMET Corporation World Headquarters

2835 KEMET Way
Simpsonville, SC 29681

Mailing Address:
P.O. Box 5928
Greenville, SC 29606

www.kemet.com
Tel: 864-963-6300
Fax: 864-963-6521

Corporate Offices
Fort Lauderdale, FL
Tel: 954-766-2800

North America

Northeast

Wilmington, MA
Tel: 978-658-1663

Southeast

Lake Mary, FL
Tel: 407-855-8886

Central

Novi, MI
Tel: 248-994-1030

Irving, TX
Tel: 972-915-6041

West

Milpitas, CA
Tel: 408-433-9950

Mexico

Guadalajara, Jalisco
Tel: 52-33-3123-2141

Europe

Southern Europe

Sasso Marconi, Italy
Tel: 39-051-939111

Skopje, Macedonia
Tel: 389-2-55-14-623

Central Europe

Landsberg, Germany
Tel: 49-8191-3350800

Kamen, Germany
Tel: 49-2307-438110

Northern Europe

Wyboston, United Kingdom
Tel: 44-1480-273082

Espoo, Finland
Tel: 358-9-5406-5000

Asia

Northeast Asia

Hong Kong
Tel: 852-2305-1168

Shenzhen, China
Tel: 86-755-2518-1306

Beijing, China
Tel: 86-10-5877-1075

Shanghai, China
Tel: 86-21-6447-0707

Seoul, South Korea
Tel: 82-2-6294-0550

Taipei, Taiwan
Tel: 886-2-27528585

Southeast Asia

Singapore
Tel: 65-6701-8033

Penang, Malaysia
Tel: 60-4-6430200

Bangalore, India
Tel: 91-806-53-76817

Note: KEMET reserves the right to modify minor details of internal and external construction at any time in the interest of product improvement. KEMET does not assume any responsibility for infringement that might result from the use of KEMET Capacitors in potential circuit designs. KEMET is a registered trademark of KEMET Electronics Corporation.

Disclaimer

All product specifications, statements, information and data (collectively, the "Information") in this datasheet are subject to change. The customer is responsible for checking and verifying the extent to which the Information contained in this publication is applicable to an order at the time the order is placed.

All Information given herein is believed to be accurate and reliable, but it is presented without guarantee, warranty, or responsibility of any kind, expressed or implied.

Statements of suitability for certain applications are based on KEMET Electronics Corporation's ("KEMET") knowledge of typical operating conditions for such applications, but are not intended to constitute – and KEMET specifically disclaims – any warranty concerning suitability for a specific customer application or use. The Information is intended for use only by customers who have the requisite experience and capability to determine the correct products for their application. Any technical advice inferred from this Information or otherwise provided by KEMET with reference to the use of KEMET's products is given gratis, and KEMET assumes no obligation or liability for the advice given or results obtained.

Although KEMET designs and manufactures its products to the most stringent quality and safety standards, given the current state of the art, isolated component failures may still occur. Accordingly, customer applications which require a high degree of reliability or safety should employ suitable designs or other safeguards (such as installation of protective circuitry or redundancies) in order to ensure that the failure of an electrical component does not result in a risk of personal injury or property damage.

Although all product-related warnings, cautions and notes must be observed, the customer should not assume that all safety measures are indicated or that other measures may not be required.