

2 x 32W DUAL BRIDGE CAR RADIO AMPLIFIER

- HIGH OUTPUT POWER CAPABILITY:
 - 2 x 35W max./4Ω
 - 2 x 32W EIAJ/4Ω
 - 2 x 22W typ./4Ω @ 14.4V, 1KHz, 10%
 - 2 x 19W typ./4Ω @ 13.2V, 1KHz, 10%
 - 2 x 28W typ./2Ω @ 14.4V, 1KHz, 10%
 - 2 x 25W typ./2Ω @ 13.2V, 1KHz, 10%
 - LOW DISTORTION
 - LOW OUTPUT NOISE
 - ST-BY FUNCTION
 - MUTE FUNCTION
 - AUTO-MUTE AT MIN. SUPPLY VOLTAGE DETECTION
 - LOW EXTERNAL COMPONENT COUNT
 - INTERNALLY FIXED GAIN (32dB)
 - NO EXTERNAL COMPENSATION
 - NO BOOTSTRAP CAPACITORS
 - ADDITIONAL MONO INPUT
- PROTECTIONS:**
- OUTPUT AC/DC SHORT CIRCUIT TO GND AND TO V_S
 - VERY INDUCTIVE LOADS
 - OVERRATING CHIP TEMPERATURE WITH SOFT THERMAL LIMITER

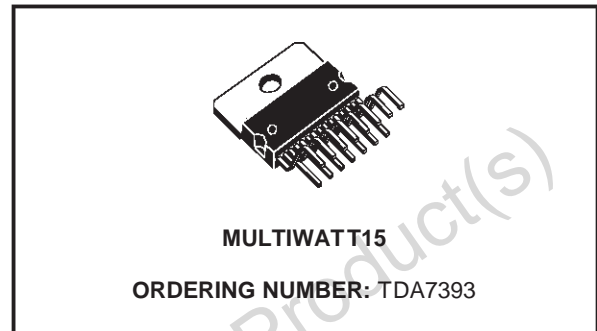

- LOAD DUMP VOLTAGE
- FORTUITOUS OPEN GND
- REVERSE BATTERY
- ESD PROTECTION

DESCRIPTION

The TDA7393 is a new technology class AB Audio Power Amplifier in Multiwatt15 package designed for high end car radio applications. Thanks to the fully complementary PNP/NPN output configuration the high power performances of the TDA7393 are obtained without bootstrap capacitors. The extremely reduced components count

BLOCK DIAGRAM

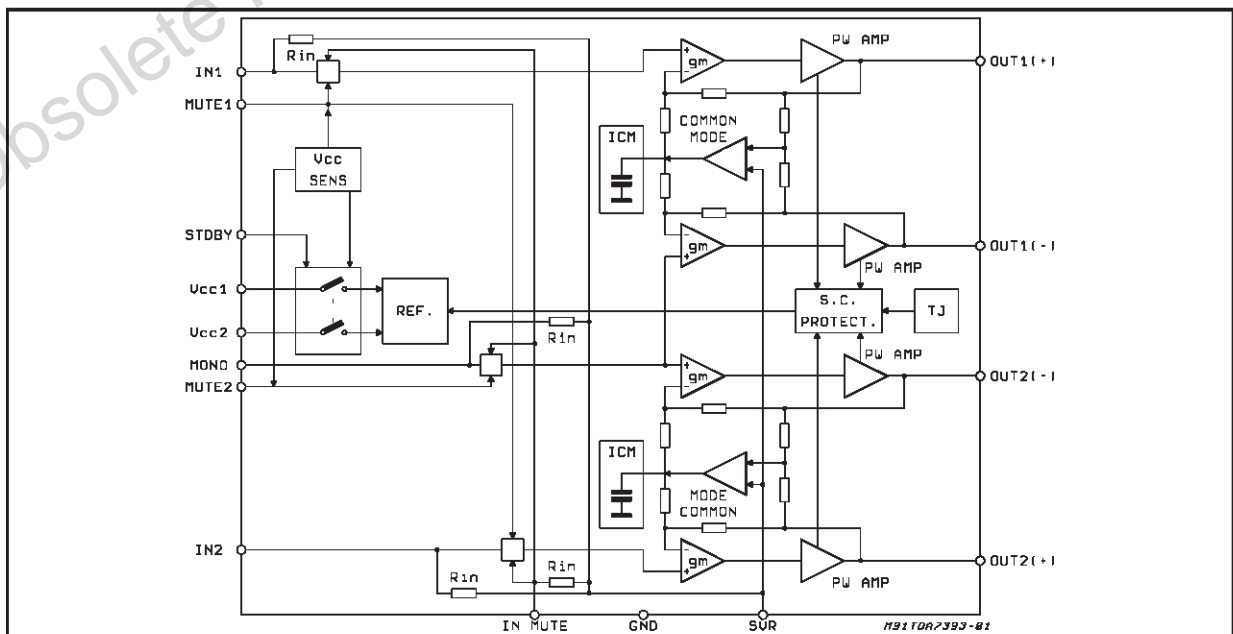

TDA7393

ABSOLUTE MAXIMUM RATINGS

Symbol	Parameter	Value	Unit
V_{CC}	Operating Supply Voltage	18	V
$V_{CC(DC)}$	DC Supply Voltage	28	V
$V_{CC(pk)}$	Peak Supply Voltage (t = 50ms)	50	V
I_o	Output Peak Current: Repetitive (Duty Cycle 10% at f = 10Hz) Non Repetitive (t = 100 μ s)	4.5	A
		5.5	A
P_{tot}	Power dissipation, T _{case} = 75°C (see derating curve)	50	W
T_j	Junction Temperature	150	°C
T_{op}	Operating Ambient Temperature	- 40 to 85	°C
T_{stg}	Storage Temperature	- 55 to 150	°C

allows very compact sets.

PIN CONNECTION (Top view)

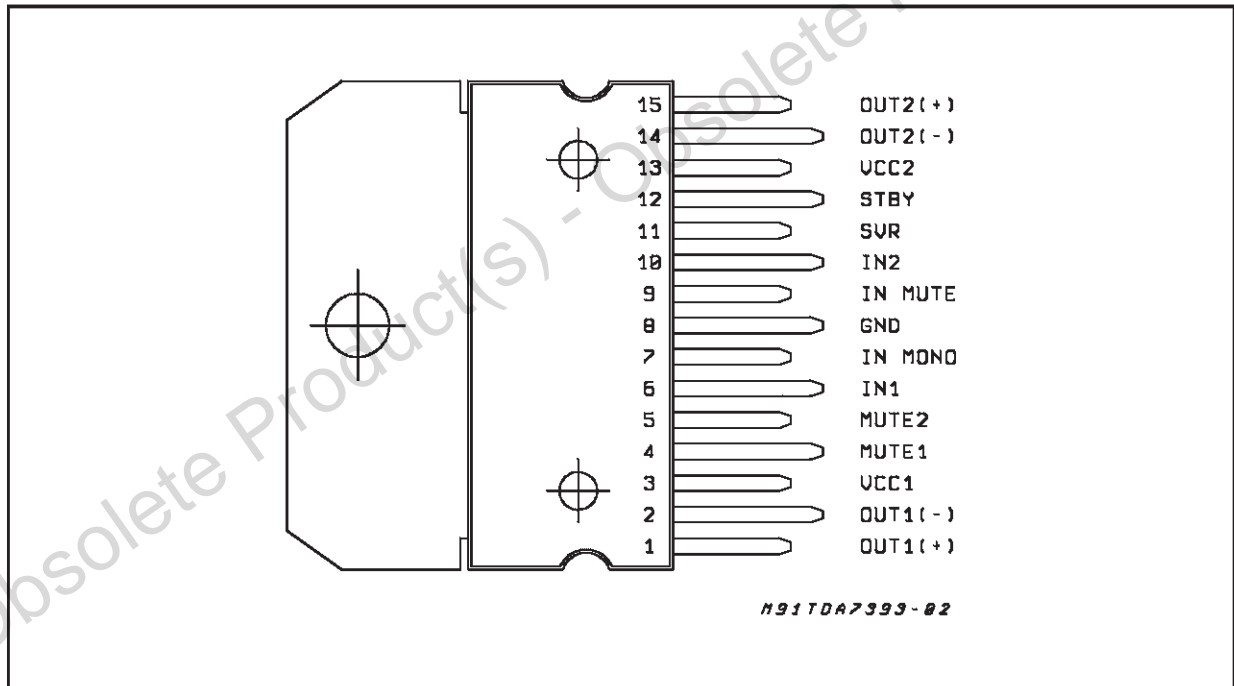

THERMAL DATA

Symbol	Parameter	Value	Unit
$R_{th j-case}$	Thermal Resistance Junction to Case	Max. 1.5	°C/W

ELECTRICAL CHARACTERISTICS ($V_S = 13.2V$; $f = 1KHz$; $R_g = 600\Omega$; $R_L = 4\Omega$; $T_{amb} = 25^\circ C$;
Refer to the application circuit, unless otherwise specified.)

Symbol	Parameter	Test Condition	Min.	Typ.	Max.	Unit
I_{q1}	Quiescent Current			90	180	mA
V_{OS}	Output Offset Voltage				150	mV
G_v	Voltage Gain		30.5	32	33.5	dB
P_o	Output Power	THD = 10%; $V_S = 14.4V$ THD = 10% THD = 1% THD = 10%; $R_L = 2\Omega$ THD = 10%; $V_S = 14.4V$; $R_L = 2\Omega$	17	22 19 16 25 28		W W W W W
$P_{o\ max}$	Max. Output Power	EIAJ RULES; $V_S = 13.7V$		30		W
THD	Distortion	$P_o = 0.1$ to 8W		0.08	0.3	%
e_{No}	Output Noise	Bw = 20Hz to 20KHz			0.3	mVrms
SVR	Supply Voltage Rejection	$f = 100Hz$ (stereo)		60		dB
f_L	Low Cut-Off Frequency			10		Hz
f_H	High Cut-Off Frequency			300		KHz
R_i	Input Impedance		10	15	20	K Ω
C_T	Cross Talk	$f = 1KHz$	50	65		dB
I_{SB}	St-By Current Consumption				100	μA
$V_{SB\ out}$	St-By OUT Threshold Voltage	Amp. ON	3.5			V
$V_{SB\ in}$	St-By IN Threshold Voltage	Amp. OFF			1.5	V
V_{SB}	Supply Dependent St-By Threshold	St-By = H, V_S reducing/increasing		7.5	8.3	V
A_M	Mute Attenuation	$V_O = 1V_{rms}$		75		dB
$V_{M\ out}$	Mute OUT Threshold Voltage	Amp. Play	3.5			V
$V_{M\ in}$	Mute IN Threshold Voltage	Amp. Mute			1.5	V
V_M	Supply Dependent Mute Threshold	Mute = IN, V_S reducing/increasing		8.5	9.3	V
$I_m(L)$	Muting Pin Current	$V_{MUTE} = 1.5V$ (Sourced Current)	6	10	14	μA
$I_m(H)$	Muting Pin Current	$V_{MUTE} = 3.5V$ (Sourced Current)	6	10	14	μA

Figure 1: Quiescent Current vs. Supply Voltage

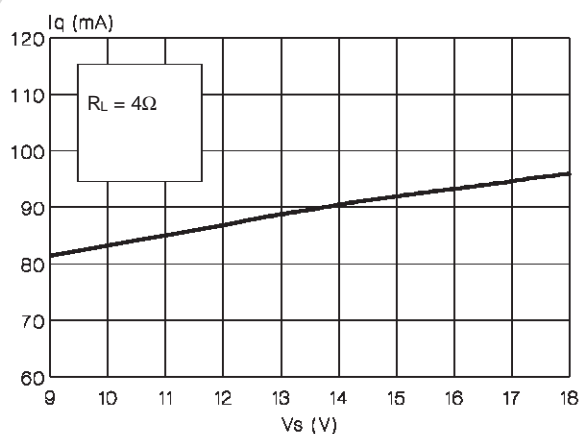

Figure 2: Output Power vs. Supply Voltage

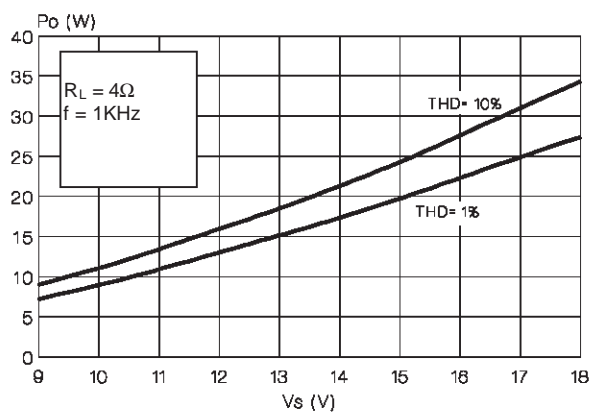

Figure 3: Output Power vs Supply Voltage

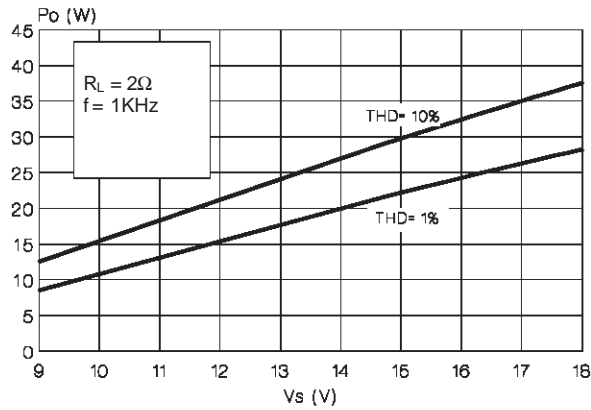

Figure 4: EIAJ Power vs. Supply Voltage

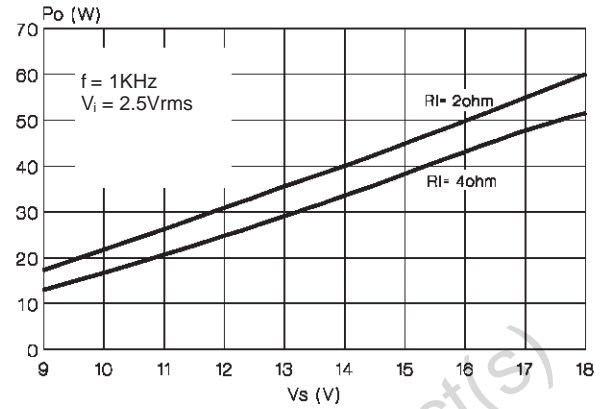

Figure 5: Cross-Talk vs. Frequency

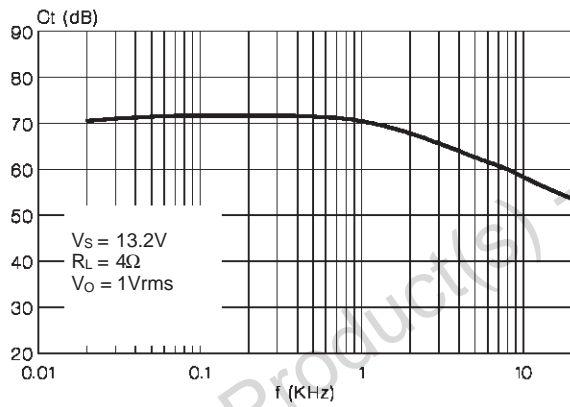

Figure 6: SVR vs. Frequency

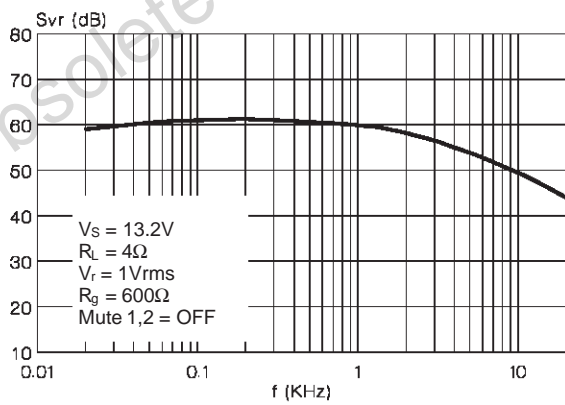

Figure 7: Distortion vs. Frequency

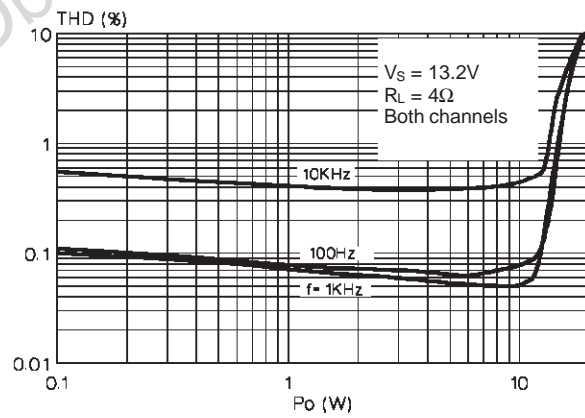

Figure 8: Distortion vs. Frequency

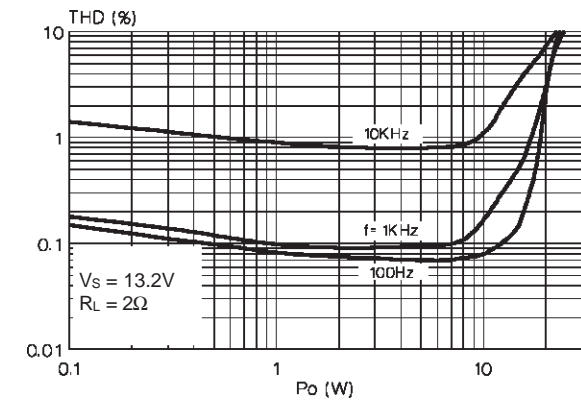

Figure 9: Block Diagram of Mute Circuit

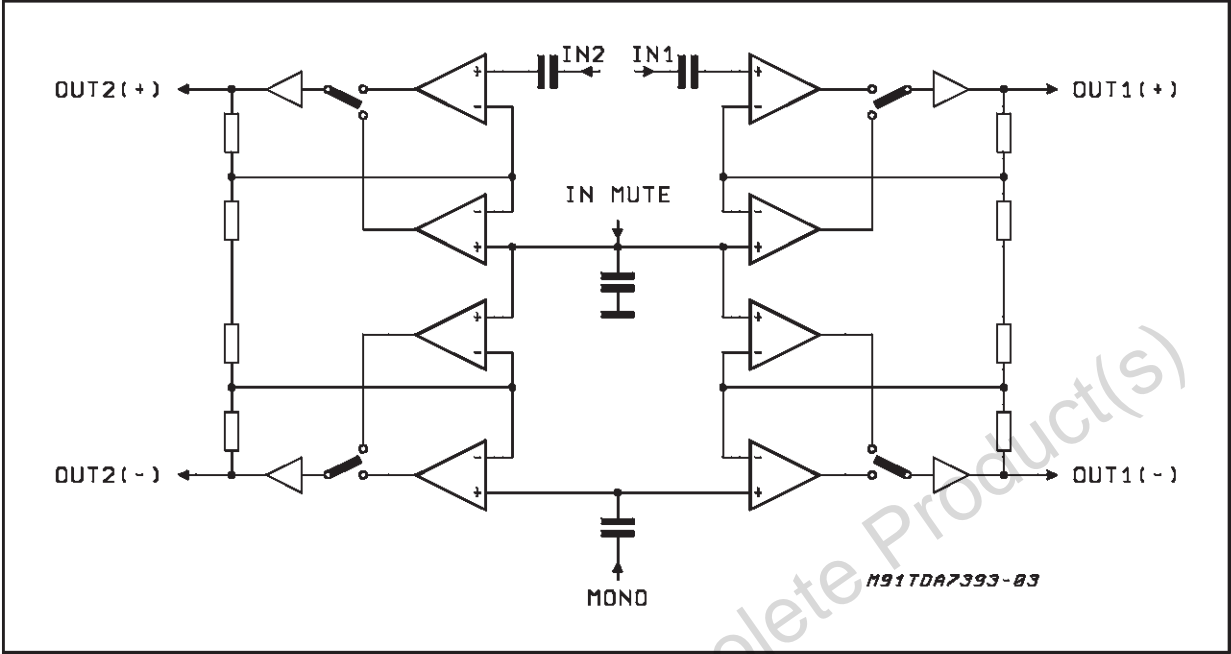

Figure 10: Explanatory Waveforms Of Mute Circuit

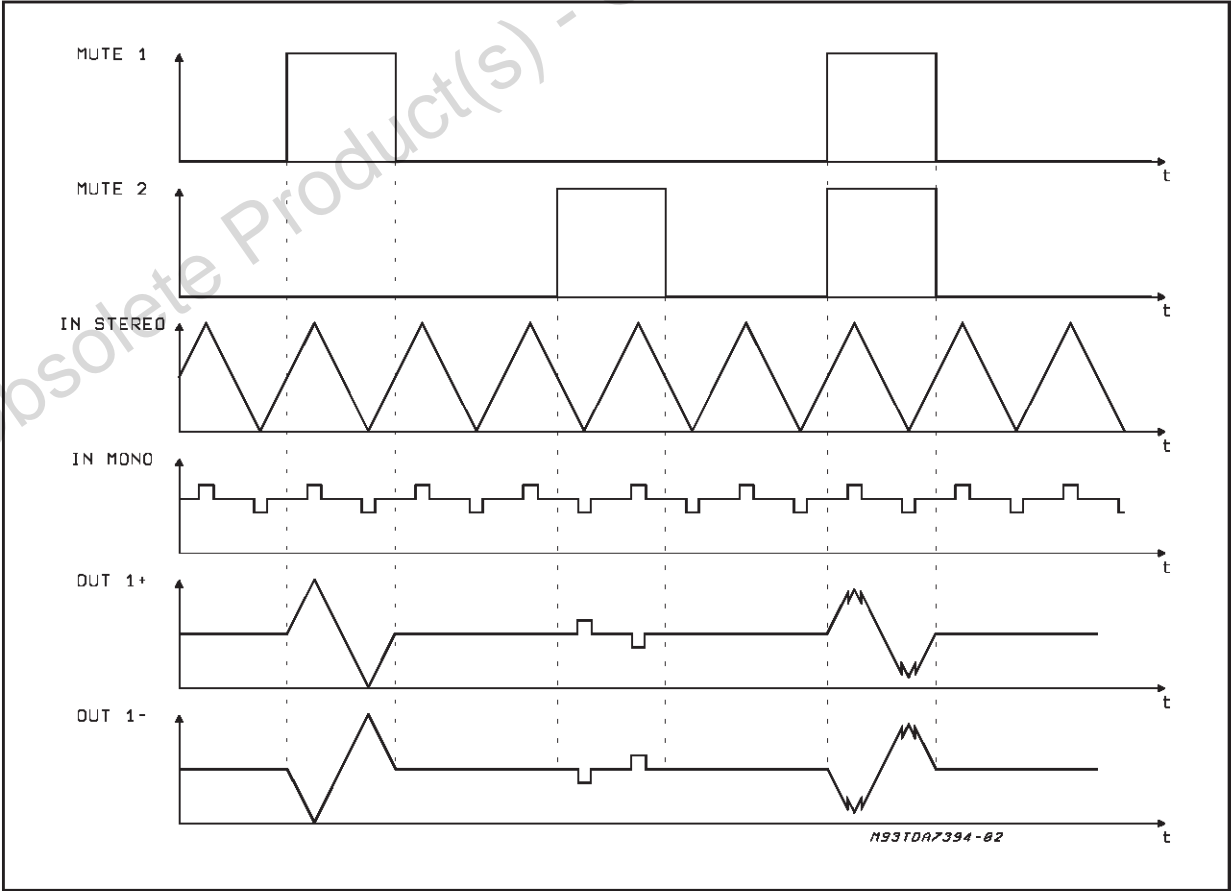

Figure 11: Application Circuit

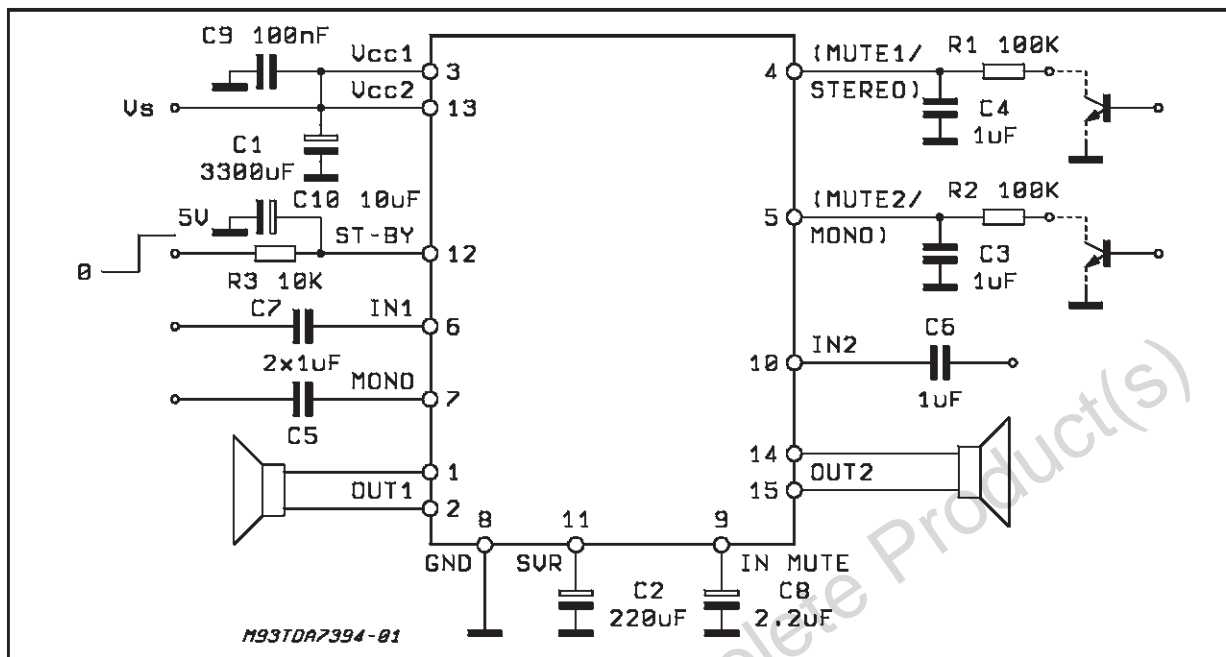

Figure 12: P.C. Board and Component Layout of the fig. 11 (1:1 scale)

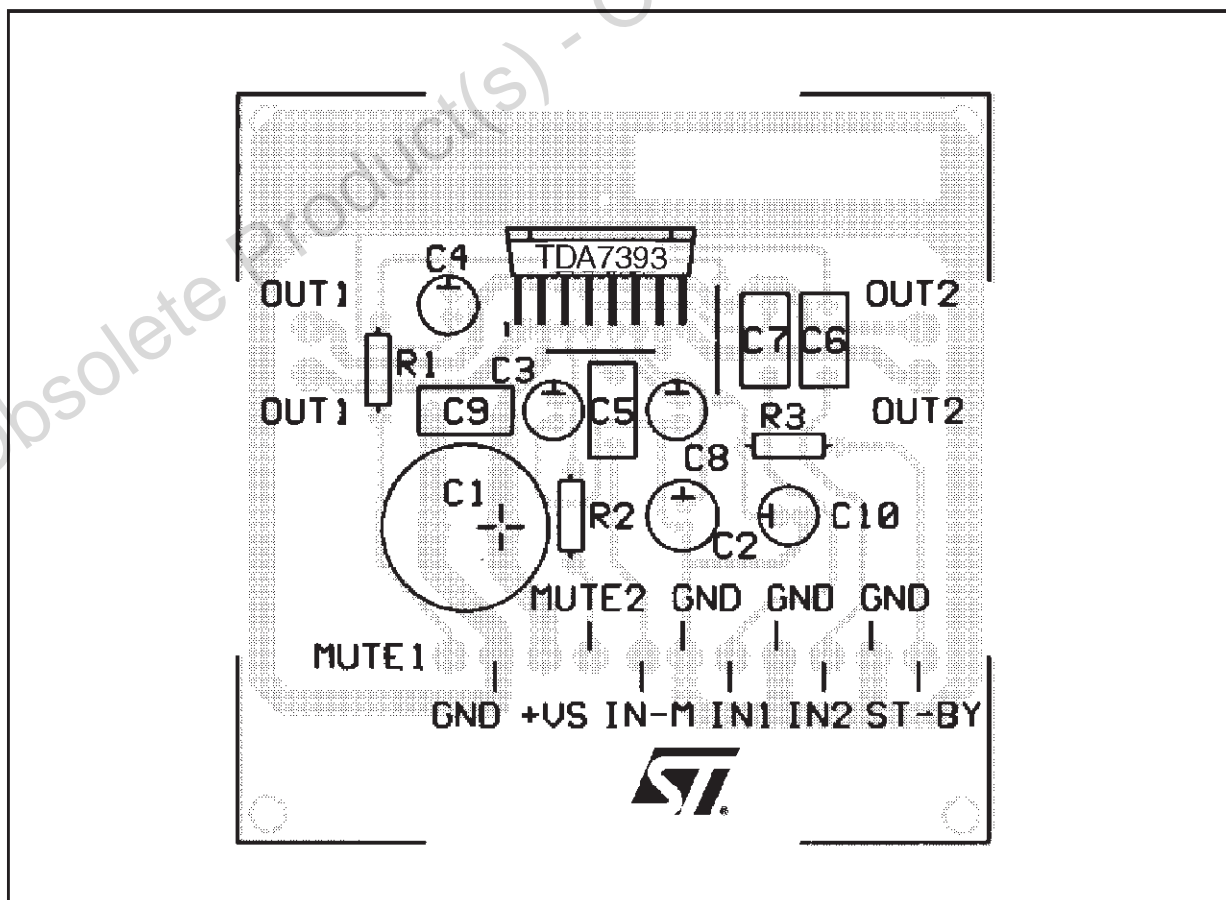
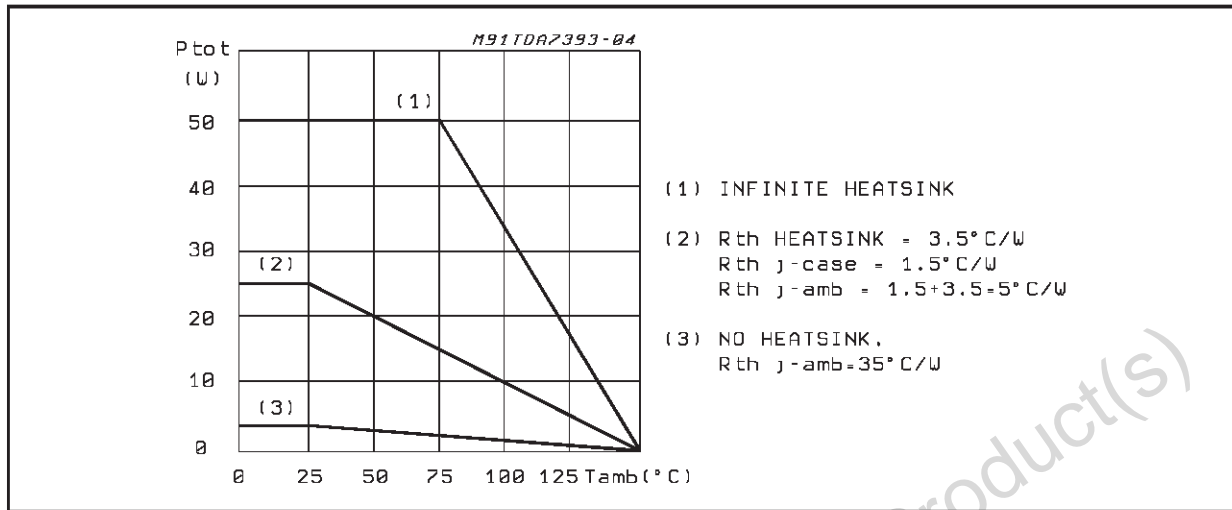

Figure 13: Power Dissipation Derating Curve



MULTIWATT15 PACKAGE MECHANICAL DATA

DIM.	mm			inch		
	MIN.	TYP.	MAX.	MIN.	TYP.	MAX.
A			5			0.197
B			2.65			0.104
C			1.6			0.063
D		1			0.039	
E	0.49		0.55	0.019		0.022
F	0.66		0.75	0.026		0.030
G	1.02	1.27	1.52	0.040	0.050	0.060
G1	17.53	17.78	18.03	0.690	0.700	0.710
H1	19.6			0.772		
H2			20.2			0.795
L	21.9	22.2	22.5	0.862	0.874	0.886
L1	21.7	22.1	22.5	0.854	0.870	0.886
L2	17.65		18.1	0.695		0.713
L3	17.25	17.5	17.75	0.679	0.689	0.699
L4	10.3	10.7	10.9	0.406	0.421	0.429
L7	2.65		2.9	0.104		0.114
M	4.25	4.55	4.85	0.167	0.179	0.191
M1	4.63	5.08	5.53	0.182	0.200	0.218
S	1.9		2.6	0.075		0.102
S1	1.9		2.6	0.075		0.102
Dia1	3.65		3.85	0.144		0.152

OUTLINE AND MECHANICAL DATA

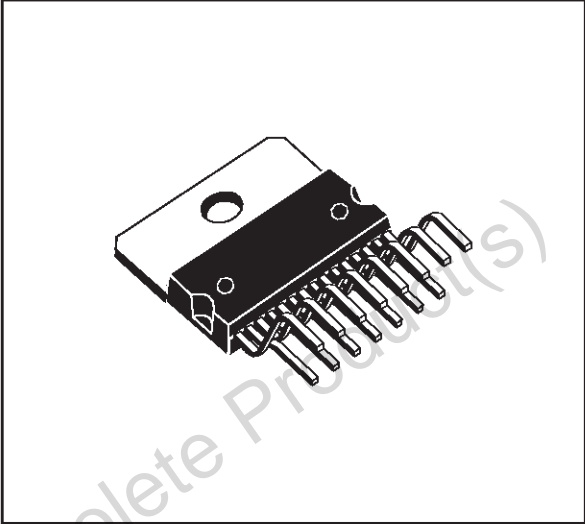

Multiwatt15 V

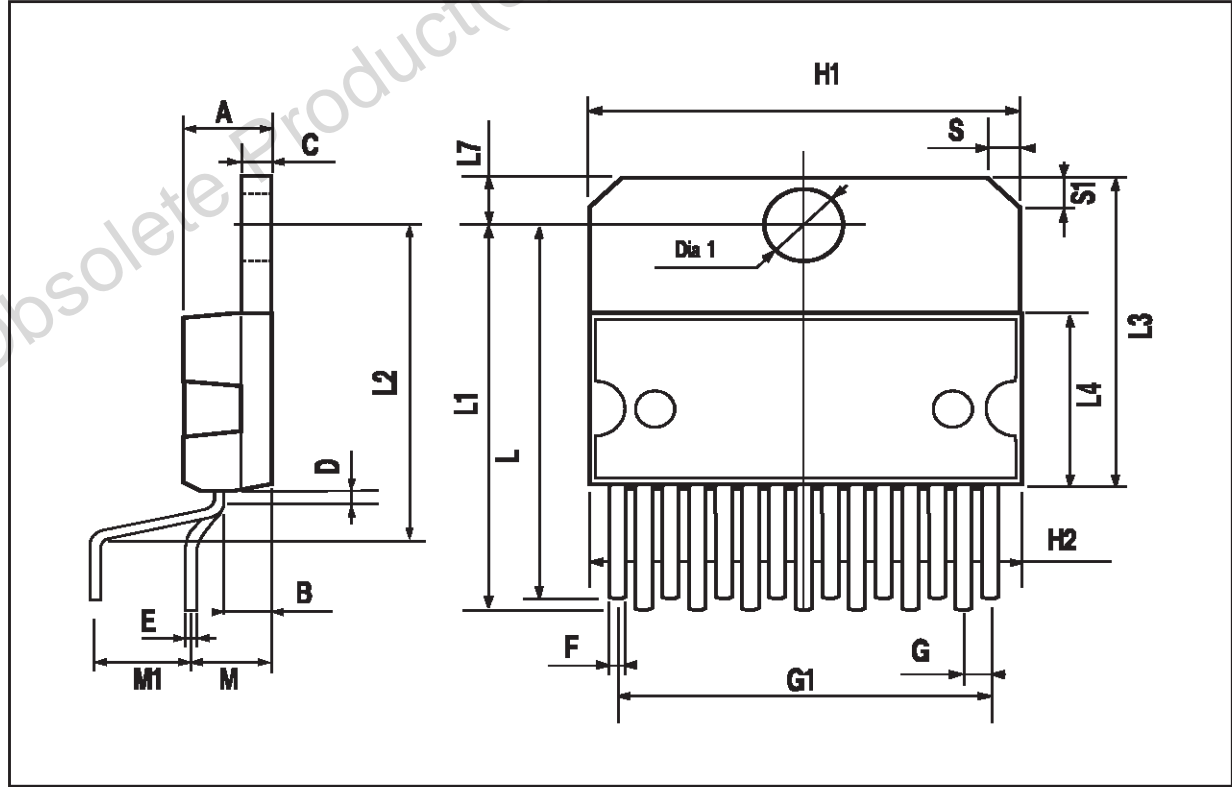

Please Read Carefully:

Information in this document is provided solely in connection with ST products. STMicroelectronics NV and its subsidiaries ("ST") reserve the right to make changes, corrections, modifications or improvements, to this document, and the products and services described herein at any time, without notice.

All ST products are sold pursuant to ST's terms and conditions of sale.

Purchasers are solely responsible for the choice, selection and use of the ST products and services described herein, and ST assumes no liability whatsoever relating to the choice, selection or use of the ST products and services described herein.

No license, express or implied, by estoppel or otherwise, to any intellectual property rights is granted under this document. If any part of this document refers to any third party products or services it shall not be deemed a license grant by ST for the use of such third party products or services, or any intellectual property contained therein or considered as a warranty covering the use in any manner whatsoever of such third party products or services or any intellectual property contained therein.

UNLESS OTHERWISE SET FORTH IN ST'S TERMS AND CONDITIONS OF SALE ST DISCLAIMS ANY EXPRESS OR IMPLIED WARRANTY WITH RESPECT TO THE USE AND/OR SALE OF ST PRODUCTS INCLUDING WITHOUT LIMITATION IMPLIED WARRANTIES OF MERCHANTABILITY, FITNESS FOR A PARTICULAR PURPOSE (AND THEIR EQUIVALENTS UNDER THE LAWS OF ANY JURISDICTION), OR INFRINGEMENT OF ANY PATENT, COPYRIGHT OR OTHER INTELLECTUAL PROPERTY RIGHT.

ST PRODUCTS ARE NOT DESIGNED OR AUTHORIZED FOR USE IN: (A) SAFETY CRITICAL APPLICATIONS SUCH AS LIFE SUPPORTING, ACTIVE IMPLANTED DEVICES OR SYSTEMS WITH PRODUCT FUNCTIONAL SAFETY REQUIREMENTS; (B) AERONAUTIC APPLICATIONS; (C) AUTOMOTIVE APPLICATIONS OR ENVIRONMENTS, AND/OR (D) AEROSPACE APPLICATIONS OR ENVIRONMENTS. WHERE ST PRODUCTS ARE NOT DESIGNED FOR SUCH USE, THE PURCHASER SHALL USE PRODUCTS AT PURCHASER'S SOLE RISK, EVEN IF ST HAS BEEN INFORMED IN WRITING OF SUCH USAGE, UNLESS A PRODUCT IS EXPRESSLY DESIGNATED BY ST AS BEING INTENDED FOR "AUTOMOTIVE, AUTOMOTIVE SAFETY OR MEDICAL" INDUSTRY DOMAINS ACCORDING TO ST PRODUCT DESIGN SPECIFICATIONS. PRODUCTS FORMALLY ESCC, QML OR JAN QUALIFIED ARE DEEMED SUITABLE FOR USE IN AEROSPACE BY THE CORRESPONDING GOVERNMENTAL AGENCY.

Resale of ST products with provisions different from the statements and/or technical features set forth in this document shall immediately void any warranty granted by ST for the ST product or service described herein and shall not create or extend in any manner whatsoever, any liability of ST.

ST and the ST logo are trademarks or registered trademarks of ST in various countries.

Information in this document supersedes and replaces all information previously supplied.

The ST logo is a registered trademark of STMicroelectronics. All other names are the property of their respective owners.

© 2013 STMicroelectronics - All rights reserved

STMicroelectronics group of companies

Australia - Belgium - Brazil - Canada - China - Czech Republic - Finland - France - Germany - Hong Kong - India - Israel - Italy - Japan - Malaysia - Malta - Morocco - Philippines - Singapore - Spain - Sweden - Switzerland - United Kingdom - United States of America

www.st.com

