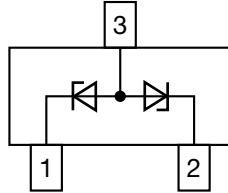


## Small Signal Zener Diodes, Dual



### LINKS TO ADDITIONAL RESOURCES



3D Models

PRIMARY CHARACTERISTICS		
PARAMETER	VALUE	UNIT
$V_Z$ range nom.	27	V
Test current $I_{ZT}$	1	mA
$V_{BR}$	27	V
$V_{WM}$	22	V
$P_{PPM}$	40	W
$T_J$ max.	150	°C
$V_Z$ specification	Pulse current	
Circuit configuration	Common anode	
Polarity	Uni-directional, bi-directional	

### FEATURES

- Dual silicon planar Zener diodes with common anode configurations
- Dual package provides for bidirectional or separate unidirectional configurations
- The dual configurations protect two separate lines with only one device
- Peak power: 40 W at 1 ms (bidirectional)
- For bidirectional operation, circuit connected to pins 1 and 2. For unidirectional operation, circuit connected to pins 1 and 3 or pins 2 and 3
- AEC-Q101 qualified available
- ESD capability according to AEC-Q101: human body model > 8 kV machine model > 800 V
- Base P/N-E3 - RoHS-compliant, commercial grade
- Base P/N-HE3 - RoHS-compliant, AEC-Q101 qualified
- Material categorization: for definitions of compliance please see [www.vishay.com/doc?99912](http://www.vishay.com/doc?99912)



ORDERING INFORMATION			
DEVICE NAME	ORDERING CODE	TAPED UNITS PER REEL	MINIMUM ORDER QUANTITY
MMBZ27VDA	MMBZ27VDA-E3-08	3000 (8 mm tape on 7" reel)	15 000
	MMBZ27VDA-HE3-08		
	MMBZ27VDA-E3-18	10 000 (8 mm tape on 13" reel)	10 000
	MMBZ27VDA-HE3-18		

PACKAGE				
PACKAGE NAME	WEIGHT	MOLDING COMPOUND FLAMMABILITY RATING	MOISTURE SENSITIVITY LEVEL	SOLDERING CONDITIONS
SOT-23	8.8 mg	UL 94 V-0	MSL level 1 (according J-STD-020)	260 °C/10 s at terminals

ABSOLUTE MAXIMUM RATINGS ( $T_{amb} = 25\text{ °C}$ , unless otherwise specified)				
PARAMETER	TEST CONDITION	SYMBOL	VALUE	UNIT
Peak power dissipation <sup>(1)</sup>		$P_{PK}$	40	W
Power dissipation on FR-5 board <sup>(2)</sup>	$T_{amb} = 25\text{ °C}$ , derate above 25 °C	$P_{tot}$	225	mW
			1.8	mW/K
Power dissipation on alumina substrate <sup>(3)</sup>	$T_{amb} = 25\text{ °C}$ , derate above 25 °C	$P_{tot}$	300	mW
			2.4	mW/K
Thermal resistance junction to ambient air		$R_{thJA}$	556	K/W
Operating temperature range		$T_{op}$	-55 to +150	°C
Storage temperature range		$T_j, T_{stg}$	-55 to +150	°C

### Notes

- (1) Non repetitive current pulse per figure 2 and derate above  $T_{amb} = 25\text{ °C}$  per figure 3  
 (2) FR-5 = 1" x 0.75" x 0.62"  
 (3) Alumina = 0.4" x 0.3" x 0.024", 99.5 % alumina

**ELECTRICAL CHARACTERISTICS** ( $T_{amb} = 25\text{ }^{\circ}\text{C}$ , unless otherwise specified)

PART NUMBER	MARKING CODE	ZENER VOLTAGE RANGE <sup>(1)</sup>			TEST CURRENT	WORKING PEAK REVERSE VOLTAGE	MAX. REVERSE LEAKAGE CURRENT	MAX. REVERSE SURGE CURRENT	MAX. REVERSE VOLTAGE (CLAMPING VOLTAGE) <sup>(2)</sup>	MAX. TEMPERATURE COEFFICIENT	MAX. FORWARD VOLTAGE	
		$V_Z$ at $I_{ZT1}$			$I_{ZT1}$	$V_{RWM}$	$I_R$ at $V_{RWM}$	$I_{PP}$	$V_C$ at $I_{RSM}$	$V_Z$	$V_F$ at $I_F$	
		V			mA	V	nA	A	V	mV/ $^{\circ}\text{C}$	V	mA
		MIN.	NOM.	MAX.								
MMBZ27VDA	TA7	25.65	27	28.35	1	22	80	1	38	30	1.1	200

**Notes**

<sup>(1)</sup>  $V_Z$  measured at pulse test current  $I_{ZT1}$  at an ambient temperature of  $25\text{ }^{\circ}\text{C}$

<sup>(2)</sup> Surge current waveform per figure 2 and derate per figure 3

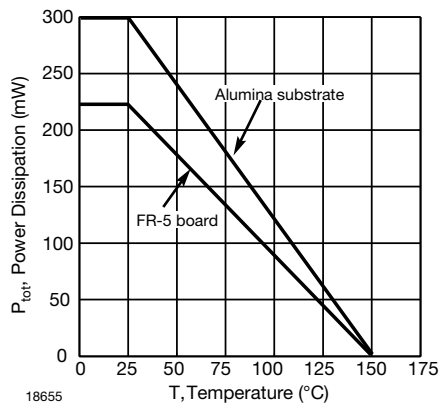
**TYPICAL CHARACTERISTICS** ( $T_{amb} = 25\text{ }^{\circ}\text{C}$ , unless otherwise specified)


Fig. 1 - Steady State Power Derating Curve

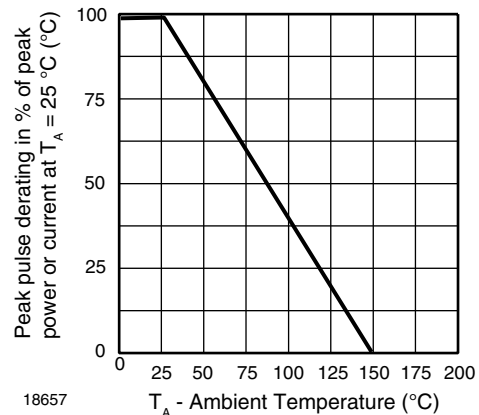


Fig. 3 - Pulse Derating Curve

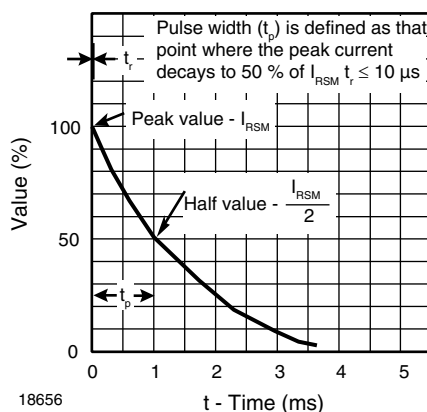
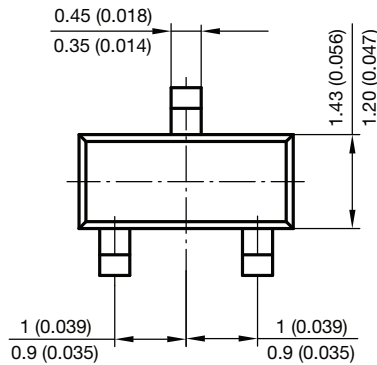
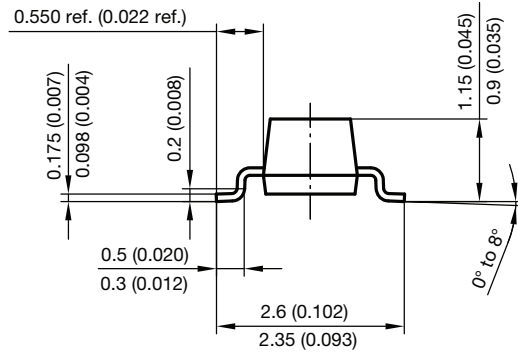
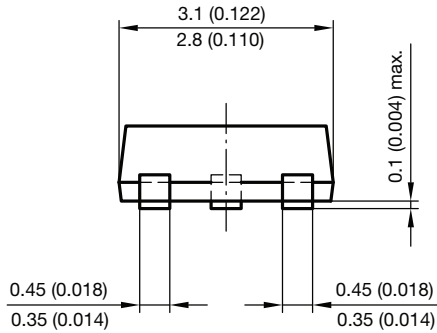


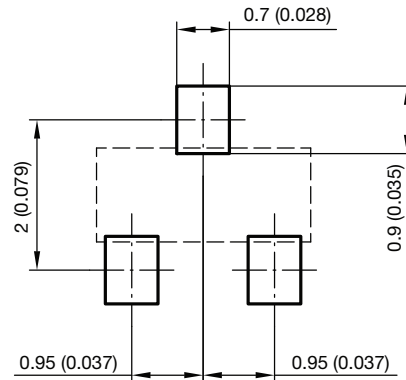
Fig. 2 - Pulse Waveform



### PACKAGE DIMENSIONS in millimeters (inches): SOT-23



Foot print recommendation:



Document no.: 6.541-5014.01-4  
Rev. 8 - Date: 23. Sep. 2009  
17418



## **Disclaimer**

ALL PRODUCT, PRODUCT SPECIFICATIONS AND DATA ARE SUBJECT TO CHANGE WITHOUT NOTICE TO IMPROVE RELIABILITY, FUNCTION OR DESIGN OR OTHERWISE.

Vishay Intertechnology, Inc., its affiliates, agents, and employees, and all persons acting on its or their behalf (collectively, "Vishay"), disclaim any and all liability for any errors, inaccuracies or incompleteness contained in any datasheet or in any other disclosure relating to any product.

Vishay makes no warranty, representation or guarantee regarding the suitability of the products for any particular purpose or the continuing production of any product. To the maximum extent permitted by applicable law, Vishay disclaims (i) any and all liability arising out of the application or use of any product, (ii) any and all liability, including without limitation special, consequential or incidental damages, and (iii) any and all implied warranties, including warranties of fitness for particular purpose, non-infringement and merchantability.

Statements regarding the suitability of products for certain types of applications are based on Vishay's knowledge of typical requirements that are often placed on Vishay products in generic applications. Such statements are not binding statements about the suitability of products for a particular application. It is the customer's responsibility to validate that a particular product with the properties described in the product specification is suitable for use in a particular application. Parameters provided in datasheets and / or specifications may vary in different applications and performance may vary over time. All operating parameters, including typical parameters, must be validated for each customer application by the customer's technical experts. Product specifications do not expand or otherwise modify Vishay's terms and conditions of purchase, including but not limited to the warranty expressed therein.

Hyperlinks included in this datasheet may direct users to third-party websites. These links are provided as a convenience and for informational purposes only. Inclusion of these hyperlinks does not constitute an endorsement or an approval by Vishay of any of the products, services or opinions of the corporation, organization or individual associated with the third-party website. Vishay disclaims any and all liability and bears no responsibility for the accuracy, legality or content of the third-party website or for that of subsequent links.

Except as expressly indicated in writing, Vishay products are not designed for use in medical, life-saving, or life-sustaining applications or for any other application in which the failure of the Vishay product could result in personal injury or death. Customers using or selling Vishay products not expressly indicated for use in such applications do so at their own risk. Please contact authorized Vishay personnel to obtain written terms and conditions regarding products designed for such applications.

No license, express or implied, by estoppel or otherwise, to any intellectual property rights is granted by this document or by any conduct of Vishay. Product names and markings noted herein may be trademarks of their respective owners.