

Voltage Regulator - Adjustable Output, Negative, 3-Terminal

1.5 A

KA337/LM337

The KA337/LM337 are 3-terminal negative adjustable regulators. They supply in excess of 1.5 A over an output voltage range of -1.25 V to -37 V. These regulators require only two external resistors to set the output voltage and employ current limiting, thermal overload protection, and safe area compensation.

Features

- Output Current in Excess of 1.5 A
- Output Adjustable between -1.2 V and -37 V
- Internal Thermal Overload Protection
- Internal Short-Circuit Current Limiting
- Output Transistor Safe-Area Compensation
- Floating Operation for High-Voltage Applications
- Eliminates Stocking many Fixed Voltages
- Standard 3-Lead TO-220 Package
- These are Pb-Free Devices

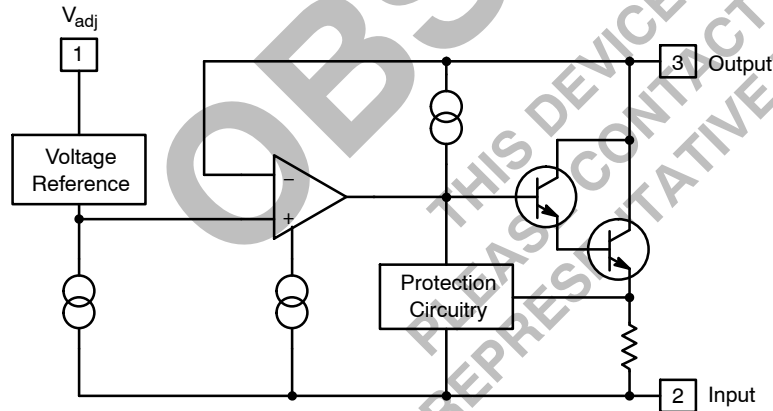
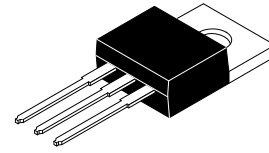
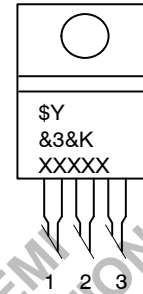

Figure 1. Block Diagram



TO-220-3LD
CASE 340AT

MARKING DIAGRAM



1. Adj.
2. Input
3. Output

\$Y = Logo
&3 = 3-Digit Date Code
&K = 2-Digit Lot Run Traceability Code

ORDERING INFORMATION

See detailed ordering and shipping information in the package dimensions section on page 5 of this data sheet.

KA337/LM337

ABSOLUTE MAXIMUM RATINGS (Values are at $T_A = +25^\circ\text{C}$, unless otherwise noted)

Symbol	Parameter	Value	Unit
$ V_I - V_O $	Input–Output Voltage Differential	40	V
P_D	Power Dissipation	Internally Limited	W
$R_{\theta JC}$	Thermal Resistance, Junction to Case	4	$^\circ\text{C}/\text{W}$
T_{OPR}	Operating Temperature Range	0 to +125	$^\circ\text{C}$
T_{STG}	Storage Temperature Range	-65 to +125	$^\circ\text{C}$

Stresses exceeding those listed in the Maximum Ratings table may damage the device. If any of these limits are exceeded, device functionality should not be assumed, damage may occur and reliability may be affected.

ELECTRICAL CHARACTERISTICS

($V_I - V_O = 5\text{ V}$, $I_O = 40\text{ mA}$, $0^\circ\text{C} \leq T_J \leq +125^\circ\text{C}$, $P_{D\text{MAX}} = 20\text{ W}$; unless otherwise specified)

Symbol	Parameter	Conditions	Min	Typ	Max	Unit
R_{line}	Line Regulation (Note 1)	$T_A = +25^\circ\text{C}$, $3\text{ V} \leq V_I - V_O \leq 40\text{ V}$	–	0.01	0.04	% / V
		$3\text{ V} \leq V_I - V_O \leq 40\text{ V}$	–	0.02	0.07	
R_{load}	Load Regulation (Note 1)	$T_A = +25^\circ\text{C}$, $10\text{ mA} \leq I_O \leq 0.5\text{ A}$	–	15	50	mV
		$10\text{ mA} \leq I_O \leq 1.5\text{ A}$	–	15	150	
I_{ADJ}	Adjustable Pin Current		–	50	100	μA
f_{ADJ}	Adjustable Pin Current Change	$T_A = +25^\circ\text{C}$, $10\text{ mA} \leq I_O \leq 1.5\text{ A}$, $3\text{ V} \leq V_I - V_O \leq 40\text{ V}$	–	2	5	μA
V_{REF}	Reference Voltage	$T_A = +25^\circ\text{C}$	-1.213	-1.250	-1.287	V
		$3\text{ V} \leq V_I - V_O \leq 40\text{ V}$, $10\text{ mA} \leq I_O \leq 1.5\text{ A}$	-1.200	-1.250	-1.300	
ST_T	Temperature Stability	$0^\circ\text{C} \leq T_J \leq +125^\circ\text{C}$		0.6	–	%
$I_{\text{L(MIN)}}$	Minimum Load Current to Maintain Regulation	$3\text{ V} \leq V_I - V_O \leq 40\text{ V}$	–	2.5	10.0	mA
		$3\text{ V} \leq V_I - V_O \leq 10\text{ V}$	–	1.5	6.0	
e_N	RMS Noise, % of V_{OUT}	$T_A = +25^\circ\text{C}$, $10\text{ Hz} \leq f \leq 10\text{ kHz}$	–	0.003	–	%
RR	Ripple Rejection Ratio	$V_O = -10\text{ V}$, $f = 120\text{ Hz}$	–	60	–	dB
		$C_{\text{ADJ}} = 10\text{ }\mu\text{F}$ (Note 2)	66	77	–	
ST	Long–Term Stability	$T_J = 125^\circ\text{C}$, 1000 Hours	–	0.3	1.0	%

Product parametric performance is indicated in the Electrical Characteristics for the listed test conditions, unless otherwise noted. Product performance may not be indicated by the Electrical Characteristics if operated under different conditions.

1. Load and line regulation are specified at constant junction temperature. Change in V_O due to heating effects must be taken into account separately. Pulse testing with low duty is used.
2. C_{ADJ} , when used, is connected between the adjustment pin and ground.

TYPICAL PERFORMANCE CHARACTERISTICS

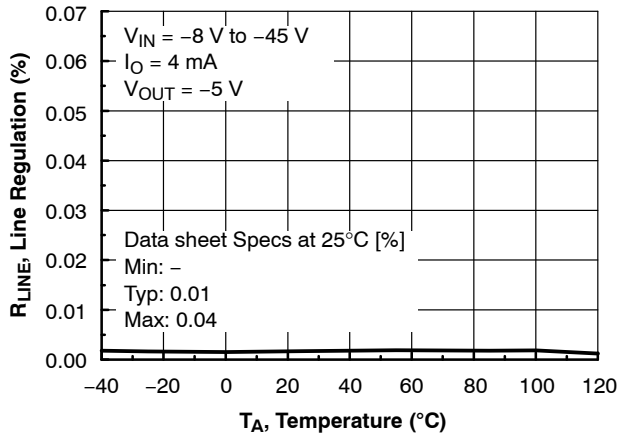

Figure 2. Line Regulation vs. Temperature

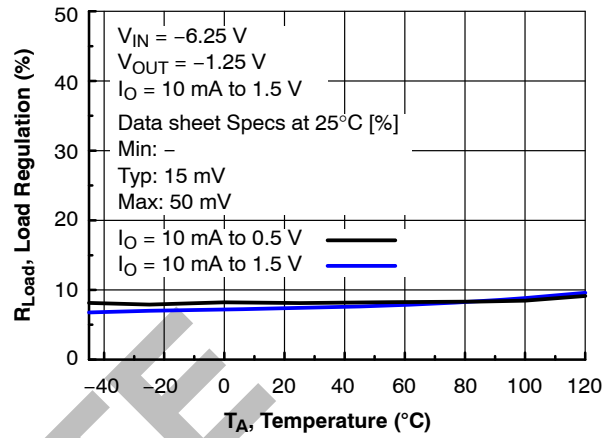

Figure 3. Load Regulation vs. Temperature

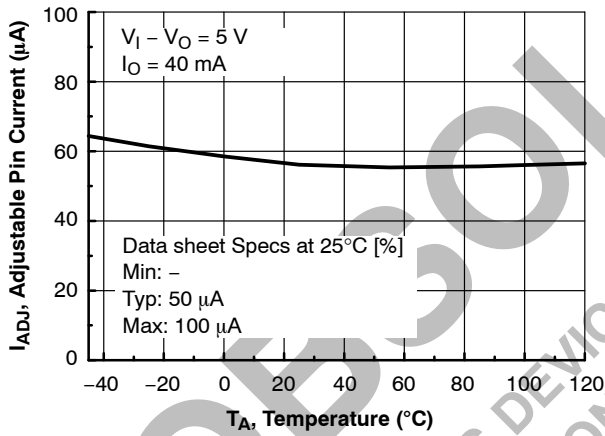

Figure 4. Adjustable Pin Current vs. Temperature

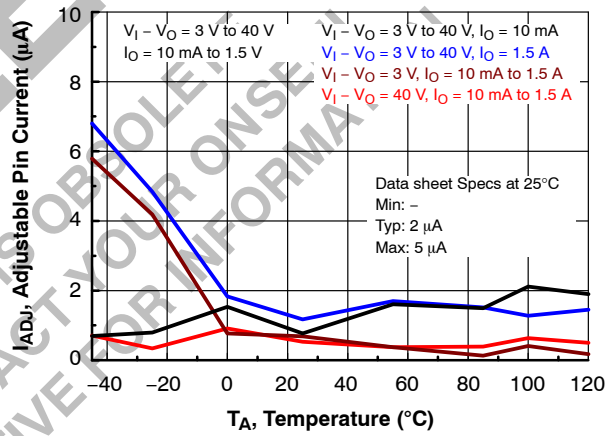

Figure 5. Adjustable Pin Current Change vs. Temperature

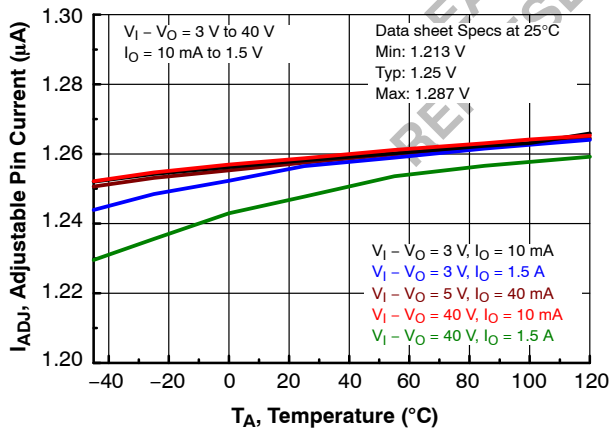

Figure 6. Reference Voltage vs. Temperature

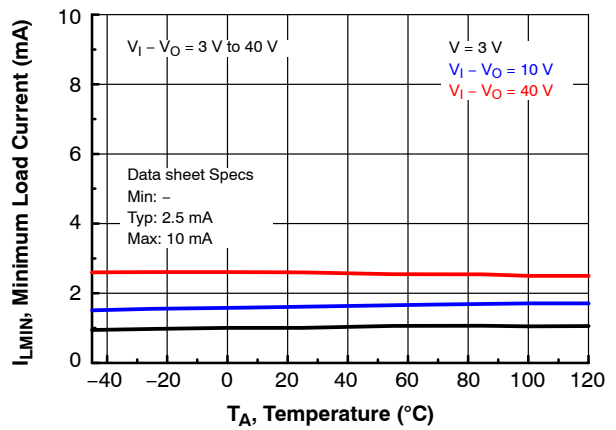

Figure 7. Minimum Load Current vs. Temperature

TYPICAL PERFORMANCE CHARACTERISTICS (Continued)

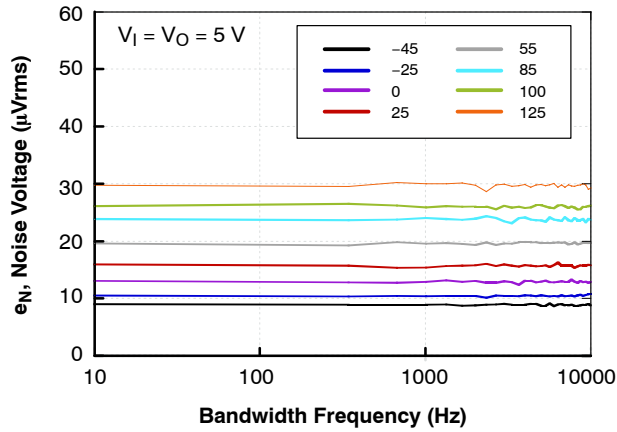

Figure 8. Noise Voltage vs. Temperature

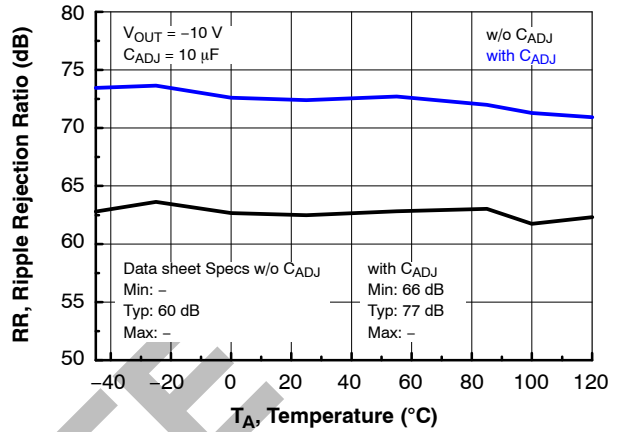

Figure 9. Ripple Rejection vs. Temperature

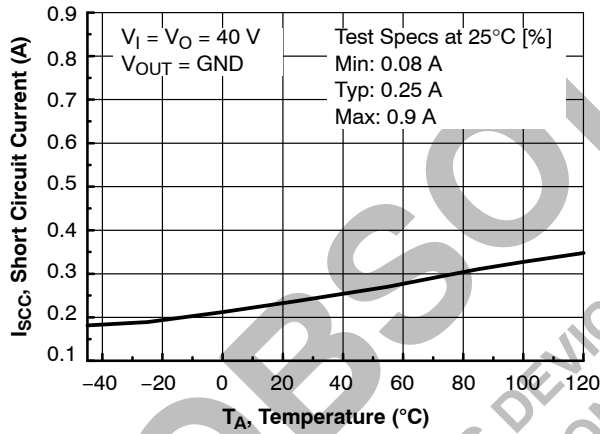

Figure 10. Short-Circuit Currents vs. Temperature

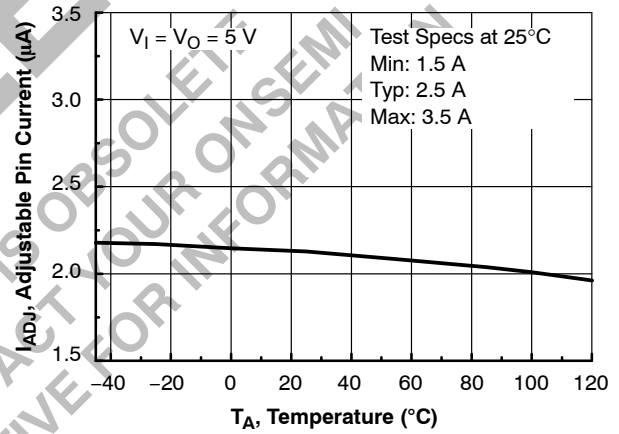
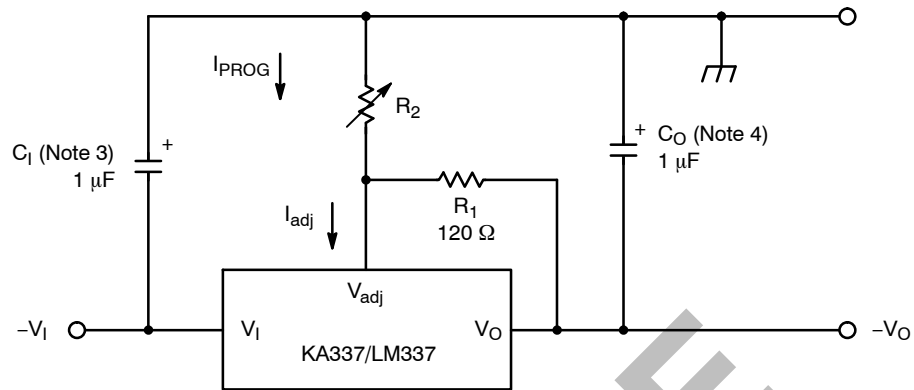

Figure 11. Peak Current vs. Temperature

KA337/LM337

TYPICAL APPLICATION



3. C_1 is required if regulator is located more than 4 inches from power supply filter.
1.0 μF solid tantalum or 10 μF aluminum electrolytic is recommended.
4. C_0 is necessary for stability. 1.0 μF solid tantalum or 10 μF aluminum electrolytic is recommended.
 $V_O = -1.25 \text{ V} (1 + R_2 / R_1)$.

Figure 12. Typical Application

ORDERING INFORMATION

Device	Operating Temperature Range	Package	Shipping
KA337TU	0°C to +125°C	TO-220-3LD, Dual Gauge (Pb-Free)	1000 Units / Tube
LM337T	0°C to +125°C	TO-220-3LD, Single Gauge (Pb-Free)	1000 Units / Tube

MECHANICAL CASE OUTLINE

PACKAGE DIMENSIONS

ON Semiconductor®

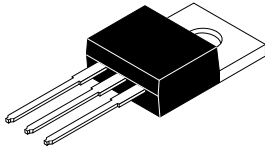

Scale 1:1

TO-220-3LD CASE 340AT ISSUE A

DATE 03 OCT 2017



- NOTES:
- A) REFERENCE JEDEC, TO-220, VARIATION AB
 - B) ALL DIMENSIONS ARE IN MILLIMETERS.
 - C) DIMENSIONS COMMON TO ALL PACKAGE SUPPLIERS EXCEPT WHERE NOTED [].
 - D) LOCATION OF MOLDED FEATURE MAY VARY (LOWER LEFT CORNER, LOWER CENTER AND CENTER OF THE PACKAGE)
 - E) DOES NOT COMPLY JEDEC STANDARD VALUE.
 - F) "A1" DIMENSIONS AS BELOW:
 SINGLE GAUGE = 0.51 - 0.61
 DUAL GAUGE = 1.10 - 1.45
 - G) PRESENCE IS SUPPLIER DEPENDENT
 - H) SUPPLIER DEPENDENT MOLD LOCKING HOLES IN HEATSINK.

DOCUMENT NUMBER:	98AON13818G	Electronic versions are uncontrolled except when accessed directly from the Document Repository. Printed versions are uncontrolled except when stamped "CONTROLLED COPY" in red.
DESCRIPTION:	TO-220-3LD	PAGE 1 OF 1

ON Semiconductor and are trademarks of Semiconductor Components Industries, LLC dba ON Semiconductor or its subsidiaries in the United States and/or other countries. ON Semiconductor reserves the right to make changes without further notice to any products herein. ON Semiconductor makes no warranty, representation or guarantee regarding the suitability of its products for any particular purpose, nor does ON Semiconductor assume any liability arising out of the application or use of any product or circuit, and specifically disclaims any and all liability, including without limitation special, consequential or incidental damages. ON Semiconductor does not convey any license under its patent rights nor the rights of others.

onsemi, **Onsemi**, and other names, marks, and brands are registered and/or common law trademarks of Semiconductor Components Industries, LLC dba "**onsemi**" or its affiliates and/or subsidiaries in the United States and/or other countries. **onsemi** owns the rights to a number of patents, trademarks, copyrights, trade secrets, and other intellectual property. A listing of **onsemi**'s product/patent coverage may be accessed at www.onsemi.com/site/pdf/Patent-Marking.pdf. **onsemi** reserves the right to make changes at any time to any products or information herein, without notice. The information herein is provided "as-is" and **onsemi** makes no warranty, representation or guarantee regarding the accuracy of the information, product features, availability, functionality, or suitability of its products for any particular purpose, nor does **onsemi** assume any liability arising out of the application or use of any product or circuit, and specifically disclaims any and all liability, including without limitation special, consequential or incidental damages. Buyer is responsible for its products and applications using **onsemi** products, including compliance with all laws, regulations and safety requirements or standards, regardless of any support or applications information provided by **onsemi**. "Typical" parameters which may be provided in **onsemi** data sheets and/or specifications can and do vary in different applications and actual performance may vary over time. All operating parameters, including "Typicals" must be validated for each customer application by customer's technical experts. **onsemi** does not convey any license under any of its intellectual property rights nor the rights of others. **onsemi** products are not designed, intended, or authorized for use as a critical component in life support systems or any FDA Class 3 medical devices or medical devices with a same or similar classification in a foreign jurisdiction or any devices intended for implantation in the human body. Should Buyer purchase or use **onsemi** products for any such unintended or unauthorized application, Buyer shall indemnify and hold **onsemi** and its officers, employees, subsidiaries, affiliates, and distributors harmless against all claims, costs, damages, and expenses, and reasonable attorney fees arising out of, directly or indirectly, any claim of personal injury or death associated with such unintended or unauthorized use, even if such claim alleges that **onsemi** was negligent regarding the design or manufacture of the part. **onsemi** is an Equal Opportunity/Affirmative Action Employer. This literature is subject to all applicable copyright laws and is not for resale in any manner.

PUBLICATION ORDERING INFORMATION

LITERATURE FULFILLMENT:

Email Requests to: orderlit@onsemi.com

onsemi Website: www.onsemi.com

TECHNICAL SUPPORT

North American Technical Support:

Voice Mail: 1 800-282-9855 Toll Free USA/Canada

Phone: 011 421 33 790 2910

Europe, Middle East and Africa Technical Support:

Phone: 00421 33 790 2910

For additional information, please contact your local Sales Representative

