

## Rad-hard high voltage CMOS logic series

### Features

- 3 to 20 V max operating voltage
- Bufferized inputs and outputs
- Standardized symmetrical outputs characteristic
- 50 ns typical propagation delays
- 100 nA max 25 °C input current
- 100% tested 20 V quiescent current
- 5-10-15 V parametric testing
- Hermetic packages
- Rad-hard 100 kRad TID at 11 rad/sec dose rate
- SEL-SEU immune to 72 MeV/cm<sup>2</sup>/mg LET ions
- ESCC qualified

### Description

The HCC40xxx and HCC45xxx series are composed of over 70 types of high voltage CMOS functions, offering a set of highly noise tolerant gates, Flip-Flops, multiplexers, counters, bus interfaces and several other functions. The radiation hardness, the single event latch-up (SEL) and the single event upset (SEU) immunity and the housing in hermetic packages of all types of both series make them usable in the most difficult environmental conditions.

The complete specification of each type is available from the European Space Components Coordination web site (ESCC): <https://spacecomponents.org/>. ST guarantees full compliance of qualified parts with these ESCC detailed specifications.

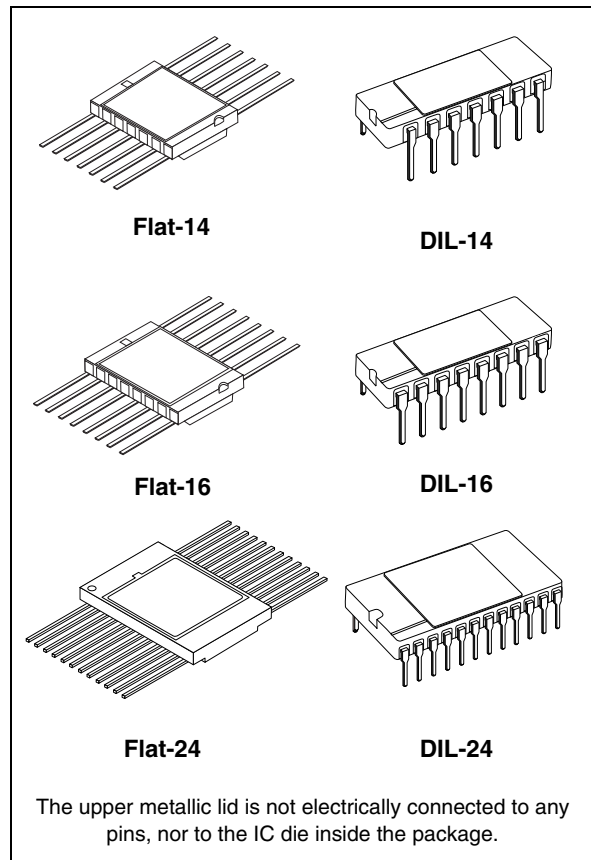

---

# Contents

<b>1</b>	<b>HCC family overview</b> .....	<b>3</b>
<b>2</b>	<b>Input equivalent circuit diagram</b> .....	<b>7</b>
<b>3</b>	<b>Maximum rating</b> .....	<b>8</b>
	3.1 Recommended operating conditions .....	8
<b>4</b>	<b>Package mechanical data</b> .....	<b>9</b>
<b>5</b>	<b>Order codes</b> .....	<b>16</b>
<b>6</b>	<b>Revision history</b> .....	<b>23</b>

# 1 HCC family overview

Table 1. Device summary

Part number	Description	Radiation level	Agency qualification	EPPL	ESCC specification	Package
HCC4001B	Rad-hard quad 2-input NOR gate	100 krad (Si)	ESCC	Y	9201/041	Flat-14 - DIL-14
HCC4002B	Rad-hard dual 4-input NOR gate			-	9201/042	Flat-14 - DIL-14
HCC4008B	Rad-hard 4-bit full adder			-	9202/039	Flat-16 - DIL-16
HCC4011B	Rad-hard quad 2-input NAND gate			Y	9201/043	Flat-14 - DIL-14
HCC4012B	Rad-hard dual 4-input NAND gate			-	9201/044	Flat-14 - DIL-14
HCC4013B	Rad-hard dual D Flip-Flop			Y	9203/023	Flat-14 - DIL-14
HCC4014B	Rad-hard 8-stage static synchronous shift register			Y	9306/014	Flat-16 - DIL-16
HCC4015B	Rad-hard dual 4-stage static shift register			Y	9306/015	Flat-16 - DIL-16
HCC4016B	Rad-hard quad bilateral switch			-	9202/050	Flat-14 - DIL-14
HCC4017B	Rad-hard decade counter/divider			Y	9204/020	Flat-16 - DIL-16
HCC4018B	Rad-hard presettable divide-by N counter			-	9204/021	Flat-16 - DIL-16
HCC4019B	Rad-hard quad AND/OR select gate			Y	9202/051	Flat-16 - DIL-16
HCC4020B	Rad-hard 14-stage binary/ripple counter			Y	9204/022	Flat-16 - DIL-16
HCC4021B	Rad-hard 8-stage static shift register			Y	9306/016	Flat-16 - DIL-16
HCC4022B	Rad-hard divide-by-8 counter/divider			-	9204/023	Flat-16 - DIL-16
HCC4023B	Rad-hard triple 3-input NAND gate			Y	9201/045	Flat-14 - DIL-14
HCC4024B	Rad-hard 7-stage binary/ripple counter	Y	9204/024	Flat-14 - DIL-14		
HCC4025B	Rad-hard triple 3-input NOR gate	-	9201/046	Flat-14 - DIL-14		
HCC4027B	Rad-hard dual J-K master-slave Flip-Flop	Y	9203/022	Flat-16 - DIL-16		
HCC4028B	Rad-hard BCD-to-decimal decoder	Y	9205/010	Flat-16 - DIL-16		
HCC4029B	Rad-hard presettable up/down counter	Y	9204/025	Flat-16 - DIL-16		



Table 1. Device summary (continued)

Part number	Description	Radiation level	Agency qualification	EPPL	ESCC specification	Package
HCC4030B	Rad-hard quad exclusive OR gate	100 krad (Si)	ESCC	Y	9201/047	Flat-14 - DIL-14
HCC4034B	Rad-hard 8-stage static bidirectional bus register			-	9306/025	Flat-24 - DIL-24
HCC4035B	Rad-hard 4-stage parallel I/O shift register			Y	9306/018	Flat-16 - DIL-16
HCC4040B	Rad-hard 12-stage binary/ripple counter			Y	9204/026	Flat-16 - DIL-16
HCC4041UB	Rad-hard quad true/complement buffer			-	9202/040	Flat-14 - DIL-14
HCC4042B	Rad-hard quad clocked D latch			-	9202/041	Flat-16 - DIL-16
HCC4043B	Rad-hard quad 3-state NOR R/S latch			-	9202/042	Flat-16 - DIL-16
HCC4044B	Rad-hard quad 3-state NAND R/S latch			-	9202/043	Flat-16 - DIL-16
HCC4046B	Rad-hard micropower phase locker loop			-	9202/044	Flat-16 - DIL-16
HCC4047B	Rad-hard monostable/astable multivibrator			Y	9207/003	Flat-14 - DIL-14
HCC4049UB	Rad-hard hex inverting buffer/convert			Y	9202/045	Flat-16 - DIL-16
HCC4050B	Rad-hard hex non-inverting buffer/convert			Y	9202/046	Flat-16 - DIL-16
HCC4051B	Rad-hard single 8-channel analog mux/demux			Y	9202/047	Flat-16 - DIL-16
HCC4052B	Rad-hard different 4-channel analog mux/demux			-	9202/048	Flat-16 - DIL-16
HCC4053B	Rad-hard triple 2-channel analog mux/demux			-	9202/049	Flat-16 - DIL-16
HCC4060B	Rad-hard 14-stage counter/divider AND oscillator			-	9204/052	Flat-16 - DIL-16
HCC4063B	Rad-hard 4-bit magnitude comparator			Y	9209/001	Flat-16 - DIL-16
HCC4066B	Rad-hard quad bilateral switch			Y	9408/005	Flat-14 - DIL-14
HCC4067B	Rad-hard single 16-channel analog mux/demux			-	9408/009	Flat-24 - DIL-24
HCC4068B	Rad-hard 8-input NAND/AND gate			-	9201/061	Flat-14 - DIL-14
HCC4069UB	Rad-hard hex inverter	Y	9401/010	Flat-14 - DIL-14		
HCC4070B	Rad-hard quad exclusive OR gate	-	9201/048	Flat-14 - DIL-14		
HCC4071B	Rad-hard quad 2-input OR gate	Y	9201/063	Flat-14 - DIL-14		
HCC4072B	Rad-hard dual 4-input OR gate	-	9201/082	Flat-14 - DIL-14		



Table 1. Device summary (continued)

Part number	Description	Radiation level	Agency qualification	EPPL	ESCC specification	Package
HCC4073B	Rad-hard triple 3-input AND gate	100 krad (Si)	ESCC	Y	9201/064	Flat-14 - DIL-14
HCC4075B	Rad-hard triple 3-input OR gate			-	9201/065	Flat-14 - DIL-14
HCC4076B	Rad-hard 4-bit D-type register			Y	9306/022	Flat-16 - DIL-16
HCC4077B	Rad-hard quad exclusive NOR gate			-	9201/055	Flat-14 - DIL-14
HCC4078B	Rad-hard 8-input NOR/OR gate			-	9201/062	Flat-14 - DIL-14
HCC4081B	Rad-hard quad 2-input AND gate			Y	9201/052	Flat-14 - DIL-14
HCC4082B	Rad-hard dual 4-input AND gate			-	9201/066	Flat-14 - DIL-14
HCC4093B	Rad-hard quad 2-input NAND Schmitt trigger			Y	9409/002	Flat-14 - DIL-14
HCC4094B	Rad-hard 8-stage shift-and-store bus register			Y	9306/026	Flat-16 - DIL-16
HCC4098B	Rad-hard dual monostable multivibrator			-	9206/002	Flat-16 - DIL-16
HCC4099B	Rad-hard 8-bit addressable latch			Y	9202/058	Flat-16 - DIL-16
HCC40103B	Rad-hard presettable 8-bit binary down counter			Y	9204/036	Flat-16 - DIL-16
HCC40106B	Rad-hard hex schmitt trigger			Y	9409/005	Flat-14 - DIL-14
HCC40107B	Rad-hard dual 2-input NAND buffer/driver			Y	9401/013	Flat-14 - DIL-14
HCC40109B	Rad-hard quad low-to-high voltage level shifter			Y	9407/003	Flat-16 - DIL-16
HCC40161B	Rad-hard binary counter with asynchronous clear			Y	9204/054	Flat-16 - DIL-16
HCC40174B	Rad-hard hex D Flip-Flop	Y	9203/038	Flat-16 - DIL-16		
HCC40193B	Rad-hard presettable 4-bit binary up-down counter	-	9204/041	Flat-16 - DIL-16		
HCC4502B	Rad-hard strobed hex inverter/buffer	Y	9401/006	Flat-16 - DIL-16		
HCC4503B	Rad-hard hex buffer 3-state non-inverter	Y	9401/030	Flat-16 - DIL-16		
HCC4508B	Rad-hard dual 4-bit Latch 3-state outputs	Y	9202/063	Flat-24 - DIL-24		
HCC4512B	Rad-hard 8-channel data selec. with 3-state output	Y	9408/006	Flat-16 - DIL-16		



**Table 1. Device summary (continued)**

Part number	Description	Radiation level	Agency qualification	EPPL	ESCC specification	Package
HCC4514B	Rad-hard 4-bit Latch / 4-to-16 line decoder output high	100 krad (Si)	ESCC	-	9408/012	Flat-24 - DIL-24
HCC4515B	Rad-hard 4-bit Latch / 4-to-16 line decoder output low			-	9205/011	Flat-24 - DIL-24
HCC4516B	Rad-hard presettable 4-bit binary up/down counter			-	9204/045	Flat-16 - DIL-16
HCC4520B	Rad-hard dual binary up-down counter			-	9204/028	Flat-16 - DIL-16
HCC4532B	Rad-hard 8-input priority encoder			-	9202/065	Flat-16 - DIL-16
HCC4538B	Rad-hard dual precision monostable multivibrator			-	9207/007	Flat-16 - DIL-16
HCC4555B	Rad-hard dual 1-of-4 decoder/demux output high			Y	9408/011	Flat-16 - DIL-16
HCC4556B	Rad-hard dual 1-of-4 decoder/demux output low			-	9408/025	Flat-16 - DIL-16

*Note: Contact ST sales office for information about the specific conditions for other CMOS4000 part numbers and product in die form*

## 2 Input equivalent circuit diagram

Figure 1. Input equivalent circuit diagram

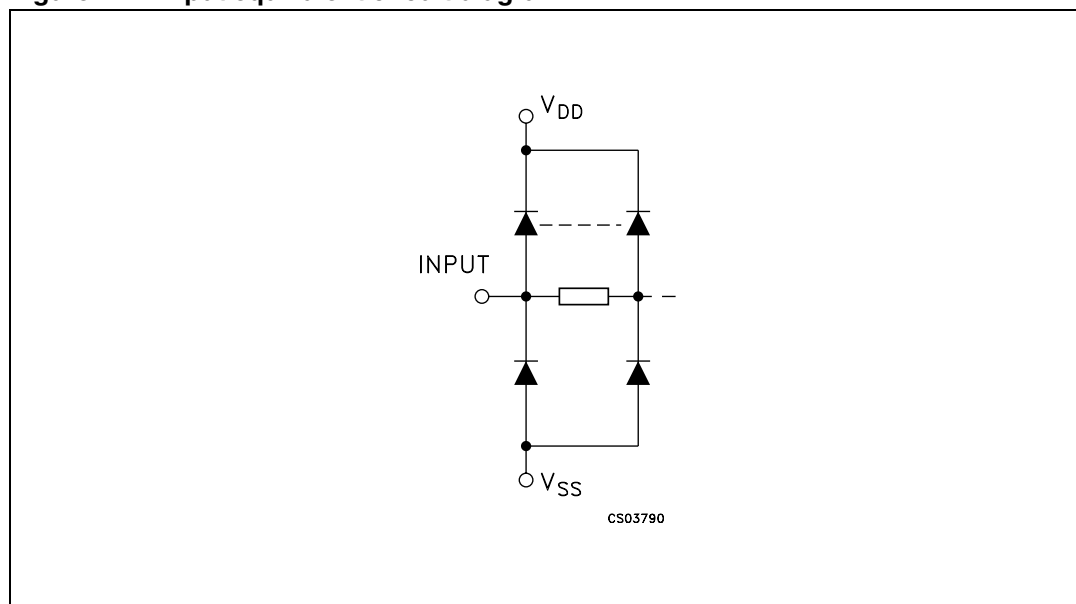

### 3 Maximum rating

Stressing the device above the rating listed in the “absolute maximum ratings” table may cause permanent damage to the device. These are stress ratings only and operation of the device at these or any other conditions above those indicated in the operating sections of this specification is not implied. Exposure to absolute maximum rating conditions for extended periods may affect device reliability.

**Table 2. Absolute maximum ratings**

Symbol	Parameter	Value	Unit
$V_{DD}$	Supply voltage	-0.5 to 22	V
$V_I$	DC input voltage	-0.5 to $V_{DD} + 0.5$	V
$I_I$	DC input current	$\pm 10$	mA
$P_D$	Power dissipation per package	200	mW
$T_{OP}$	Operating temperature	-55 to +125	°C
$T_{STG}$	Storage temperature	-65 to +150	°C

*Note:* All voltage values are referred to  $V_{SS}$  pin voltage.

#### 3.1 Recommended operating conditions

**Table 3. Recommended operating conditions**

Symbol	Parameter	Value	Unit
$V_{DD}$	Supply voltage	20	V
$V_I$	Input voltage	0 to $V_{DD}$	V
$T_{OP}$	Operating temperature	-55 to +125	°C



## 4 Package mechanical data

In order to meet environmental requirements, ST offers these devices in different grades of ECOPACK<sup>®</sup> packages, depending on their level of environmental compliance. ECOPACK<sup>®</sup> specifications, grade definitions and product status are available at: [www.st.com](http://www.st.com). ECOPACK is an ST trademark.

**Table 4. Ceramic Flat-14 mechanical data**

Dim	mm		
	Min	Typ	Max
A	6.75	6.91	7.06
B	9.76	9.95	10.14
C	1.49		1.95
D	0.10	0.127	0.15
E	7.50	7.62	7.75
F		1.27	
G	0.38	0.43	0.48
H		6.0	
L	18.75	en	22.0
M		0.38	
N		4.31	

**Figure 2. Ceramic Flat-14 mechanical drawings**

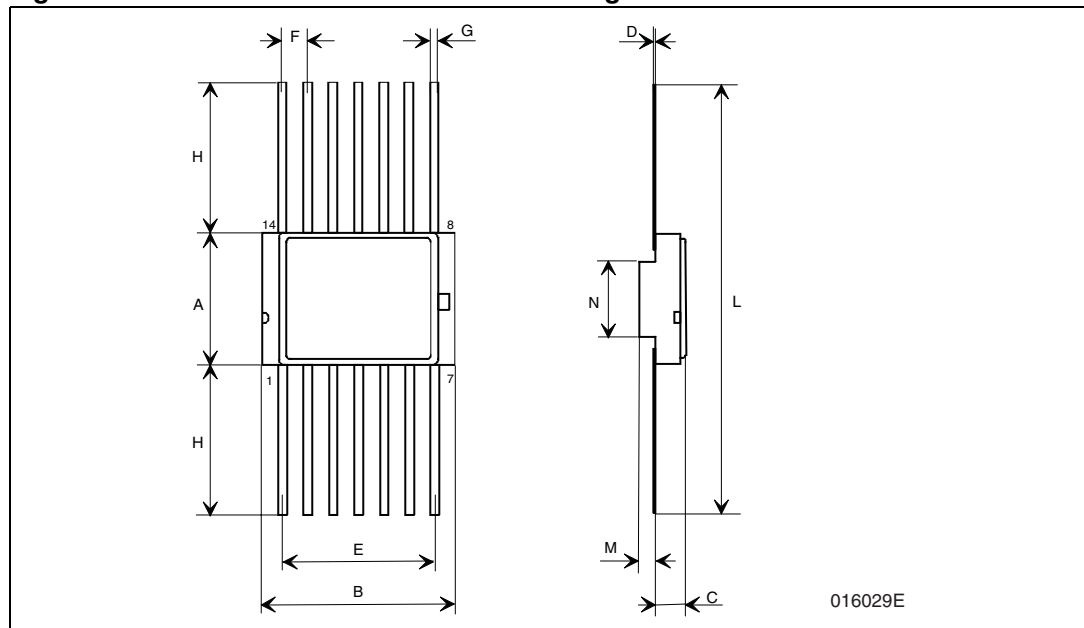

*Note: The upper metallic lid is not electrically connected to any pins, nor to the IC die inside the package. Connecting unused pins or metal lid to ground or to the power supply will not affect the electrical characteristics.*

Table 5. Ceramic DIL-14 mechanical data

Dim.	Mm.		
	Min.	Typ	Max.
A	2.1		2.54
a1	3.00		3.70
a2	0.63	0.88	1.14
B	1.82	2.03	2.39
b	0.40	0.45	0.50
b1	0.20	0.254	0.30
D	18.79	19.00	19.20
E	7.36	7.62	7.87
e		2.54	
e1	15.11	15.24	15.37
e2	7.62	7.87	8.12
F	7.11		7.75
I			3.70
K	10.90		12.1 n
L	1.14	1.27	1.5

Figure 3. Ceramic DIL-14 mechanical drawings

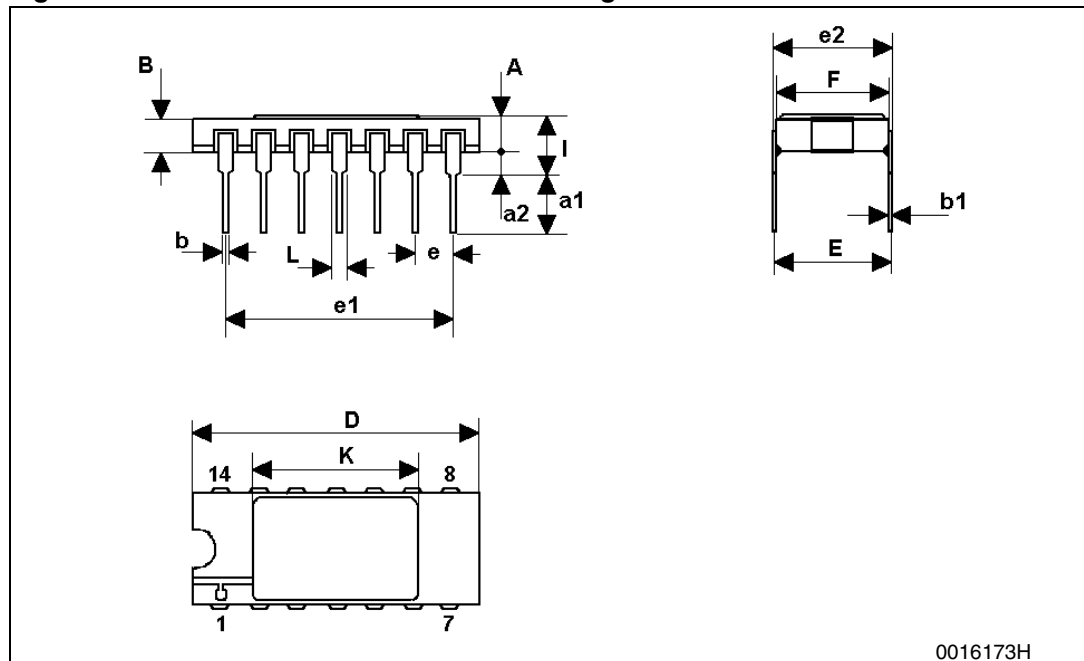

Note: The upper metallic lid is not electrically connected to any pins, nor to the IC die inside the package. Connecting unused pins or metal lid to ground or to the power supply will not affect the electrical characteristics.

**Table 6. Ceramic Flat-16 mechanical data**

Dim.	mm.		
	Min.	Typ	Max.
A	6.75	6.91	7.06
B	9.76	9.94	10.14
C	1.49		1.95
D	0.102	0.127	0.152
E	8.76	8.89	9.01
F		1.27	
G	0.38	0.43	0.48
H	6.0		
L	18.75	en	22.0
M	0.33	0.38	0.43
N		4.31	

**Figure 4. Ceramic Flat-16 mechanical drawings**

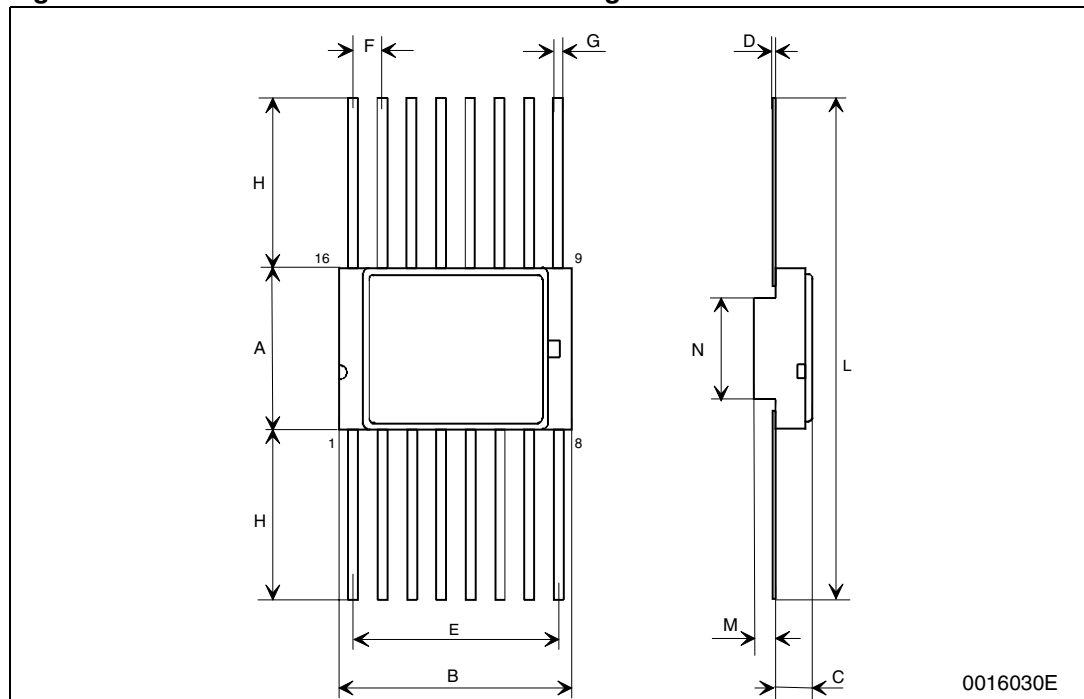

*Note: The upper metallic lid is not electrically connected to any pins, nor to the IC die inside the package. Connecting unused pins or metal lid to ground or to the power supply will not affect the electrical characteristics.*

Table 7. Ceramic DIL-16 package dimensions

Dim	mm		
	Min	Typ	Max
A	2.10		2.71
a1	3.00		3.70
a2	0.63	0.88	1.14
B	1.82		2.39
b	0.40	0.45	0.50
b1	0.20	0.254	0.30
D	20.06	20.32	20.58
E	7.36	7.62	7.87
e		2.54	
e1	17.65	17.78	17.90
e2	7.62	7.87	8.12
F	7.29	7.49	7.70
I			3.83
K	10.90		12.10
L	1.14		1.50

Figure 5. Ceramic DIL-16 package drawings

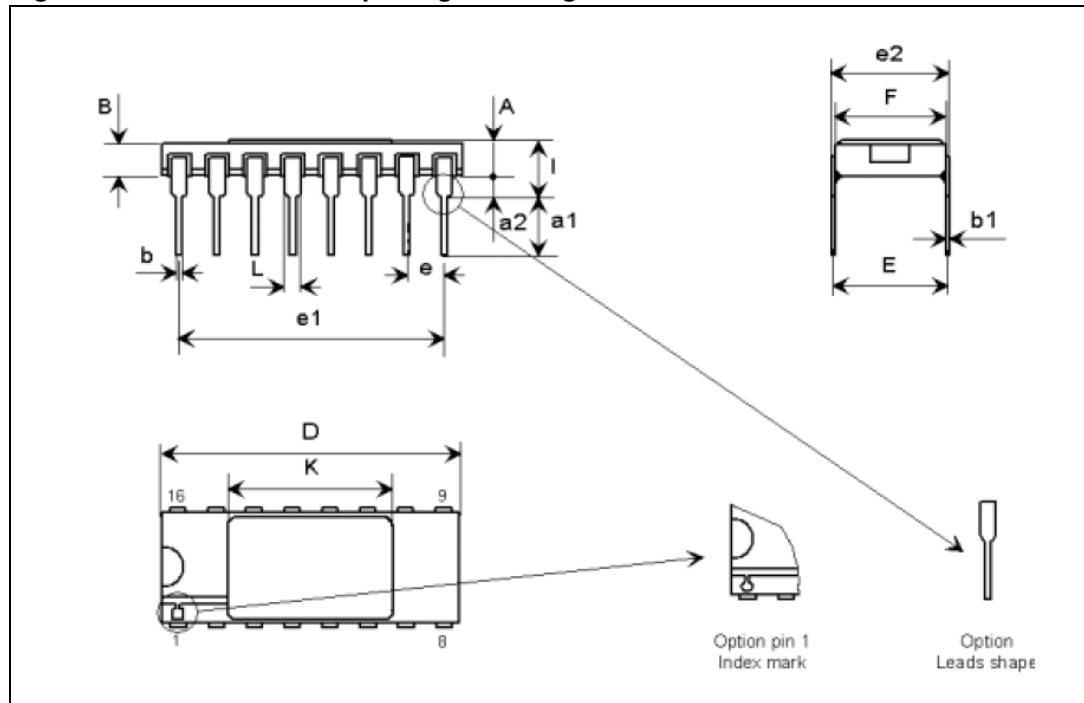

Note: The upper metallic lid is not electrically connected to any pins, nor to the IC die inside the package. Connecting unused pins or metal lid to ground or to the power supply will not affect the electrical characteristics.



**Table 8. Ceramic Flat-24 package dimensions**

Dim	mm		
	Min	Typ	Max
A	10.70	11.00	11.30
B	15.30	15.49	15.70
C	1.45		1.90
D	0.23	0.254	0.30
E	13.84	13.97	14.10
F	1.22	1.27	1.32
G	0.45	0.508	0.55
H	7.25		8.25
L	25.00		28.00
M	0.45	0.508	0.55
N		7.01	

**Figure 6. Ceramic Flat-24 package drawings**

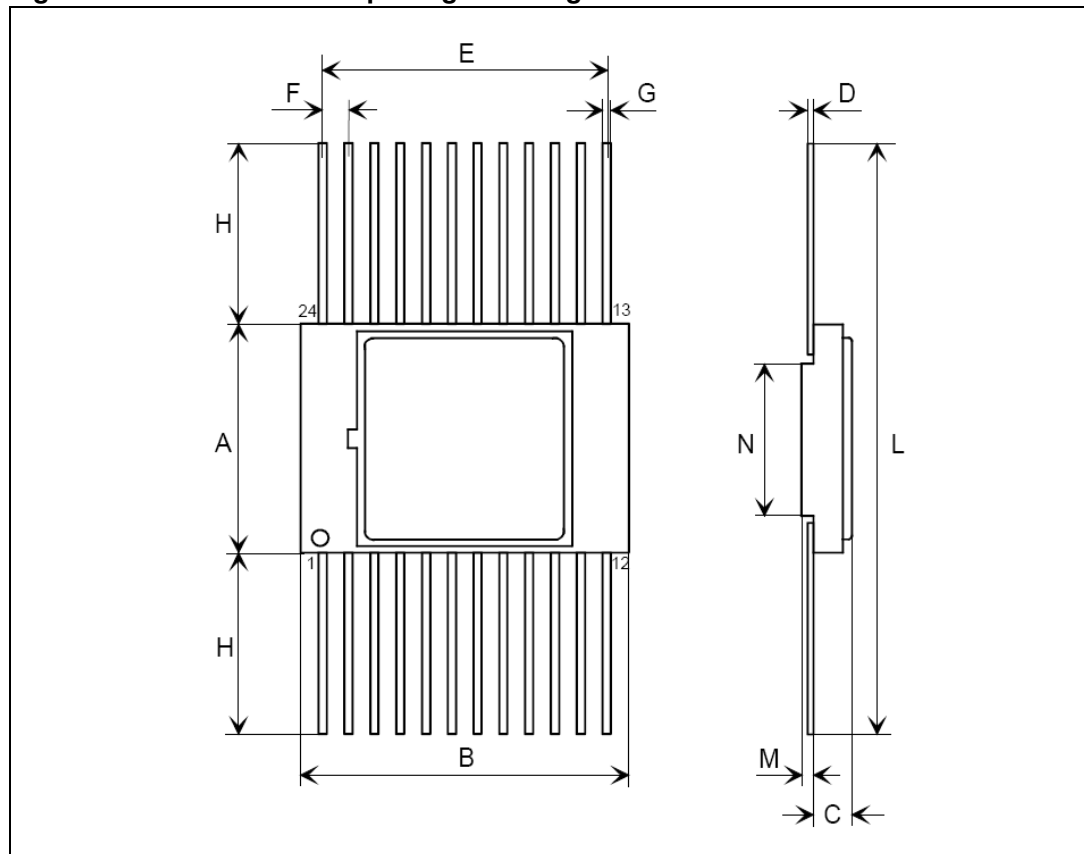

*Note: The upper metallic lid is not electrically connected to any pins, nor to the IC die inside the package. Connecting unused pins or metal lid to ground or to the power supply will not affect the electrical characteristics.*

**Table 9. Ceramic DIL-24 package dimensions**

Dim	mm		
	Min	Typ	Max
A	2.159	1.931	2.387
a1	1.270	1.016	1.524
a2	0.307	0.274	0.340
B	1.270		
b1	0.457	0.407	0.507
b2	.254	0.229	0.304
C	2.466	2.205	2.727
D	30.48	30.17	30.78
E	15.24	14.98	15.49
e	2.540	2.410	2.670
e3	27.94	27.81	28.06
F	15.11	14.85	15.36
K	12.80	12.60	13.00
K1	12.80	12.60	13.00
L	3.300	3.000	3.800

**Figure 7. Ceramic DIL-24 package drawings**

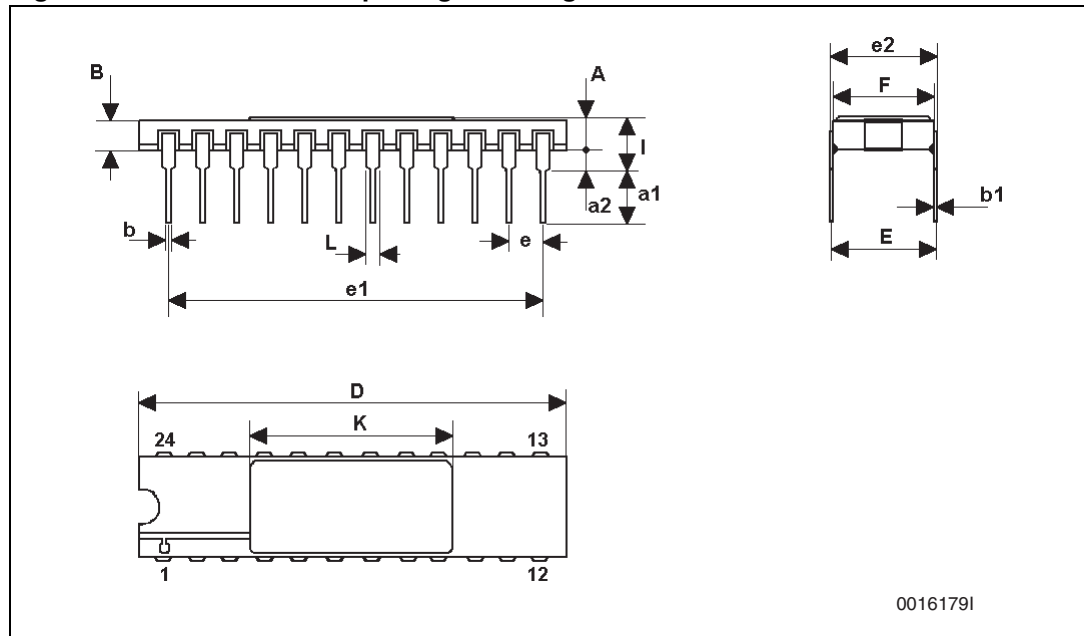

**Note:** *The upper metallic lid is not electrically connected to any pins, nor to the IC die inside the package. Connecting unused pins or metal lid to ground or to the power supply will not affect the electrical characteristics.*

## 5 Order codes

Table 10. Ordering information

Order code	ESCC detailed specification	Quality level	Comment	Package	Lead finish	Marking	Mass (g)	EPPL	Packing
HCC4001BK	9201/041/01 or 02	ESCC flight	Specify ESCC variant number in PO	Flat-14	Gold or solder dip	920104101 or 02	0.70	Y	Strip pack
HCC4001BD	9201/041/03 or 04			DIL-14		920104103 or 04	2.20	-	
HCC4002BK	9201/042/01 or 02			Flat-14		920104201 or 02	0.70	-	
HCC4002BD	9201/042/03 or 04			DIL-14		920104203 or 04	2.20	-	
HCC4008BK	9202/039/01 or 02			Flat-16		920203901 or 02	0.70	-	
HCC4008BD	9202/039/08 or 09			DIL-16		920203908 or 09	2.20	-	
HCC4011BK	9201/043/01 or 02			Flat-14		920104301 or 02	0.70	Y	
HCC4011BD	9201/043/03 or 04			DIL-14		920104303 or 04	2.20	-	
HCC4012BK	9201/044/01 or 02			Flat-14		920104401 or 02	0.70	-	
HCC4012BD	9201/044/03 or 04			DIL-14		920104403 or 04	2.20	-	
HCC4013BK	9203/023/01 or 02			Flat-14		920302301 or 02	0.70	Y	
HCC4013BD	9203/023/03 or 04			DIL-14		920302303 or 04	2.20	-	
HCC4014BK	9306/014/01 or 02			Flat-16		930601401 or 02	0.70	Y	
HCC4014BD	9306/014/08 or 09			DIL-16		930601408 or 09	2.20	-	
HCC4015BK	9306/015/01 or 02			Flat-16		930601501 or 02	0.70	Y	
HCC4015BD	9306/015/08 or 09			DIL-16		930601508 or 09	2.20	-	
HCC4016BK	9202/050/01 or 02			Flat-14		920205001 or 02	0.70	-	
HCC4016BD	9202/050/03 or 04			DIL-14		920205003 or 04	2.20	-	
HCC4017BK	9204/020/01 or 02			Flat-16		920402001 or 02	0.70	Y	
HCC4017BD	9204/020/08 or 09			DIL-16		920402008 or 09	2.20	-	
HCC4018BK	9204/021/01 or 02			Flat-16		920402101 or 02	0.70	-	
HCC4018BD	9204/021/08 or 09			DIL-16		920402108 or 09	2.20	-	





Table 10. Ordering information (continued)

Order code	ESCC detailed specification	Quality level	Comment	Package	Lead finish	Marking	Mass (g)	EPPL	Packing
HCC4019BK	9202/051/01 or 02			Flat-16		920205101 or 02	0.70	Y	
HCC4019BD	9202/051/08 or 09			DIL-16		920205108 or 09	2.20	-	
HCC4020BK	9204/022/01 or 02			Flat-16		920402201 or 02	0.70	Y	
HCC4020BD	9204/022/08 or 09			DIL-16		920402208 or 09	2.20	-	
HCC4021BK	9306/016/01 or 02			Flat-16		930601601 or 02	0.70	Y	
HCC4021BD	9306/016/08 or 09			DIL-16		930601608 or 09	2.20	-	
HCC4022BK	9204/023/01 or 02			Flat-16		920402301 or 02	0.70	-	
HCC4022BD	9204/023/08 or 09			DIL-16		920402308 or 09	2.20	-	
HCC4023BK	9201/045/01 or 02			Flat-14		920104501 or 02	0.70	Y	
HCC4023BD	9201/045/03 or 04			DIL-14		920104503 or 04	2.20	-	
HCC4024BK	9204/024/01 or 02			Flat-14		920402401 or 02	0.70	Y	
HCC4024BD	9204/024/03 or 04			DIL-14		920402403 or 04	2.20	-	
HCC4025BK	9201/046/01 or 02	ESCC flight	Specify ESCC variant number in PO	Flat-14	Gold or solder dip	920104601 or 02	0.70	-	Strip pack
HCC4025BD	9201/046/03 or 04			DIL-14		920104603 or 04	2.20	-	
HCC4027BK	9203/022/01 or 02			Flat-16		920302201 or 02	0.70	Y	
HCC4027BD	9203/022/08 or 09			DIL-16		920302208 or 09	2.20	-	
HCC4028BK	9205/010/01 or 02			Flat-16		920501001 or 02	0.70	Y	
HCC4028BD	9205/010/08 or 09			DIL-16		920501008 or 09	2.20	-	
HCC4029BK	9204/025/01 or 02			Flat-16		920402501 or 02	0.70	Y	
HCC4029BD	9204/025/08 or 09			DIL-16		920402508 or 09	2.20	-	
HCC4030BK	9201/047/01 or 02			Flat-14		920104701 or 02	0.70	Y	
HCC4030BD	9201/047/03 or 04			DIL-14		920104703 or 04	2.20	-	
HCC4034BK	9306/025/01 or 02			Flat-24		930602501 or 02	1.70	-	
HCC4034BD	9306/025/03 or 04			DIL-24		930602503 or 04	5.20	-	
HCC4035BK	9306/018/01 or 02			Flat-16		930601801 or 02	0.70	Y	



Table 10. Ordering information (continued)

Order code	ESCC detailed specification	Quality level	Comment	Package	Lead finish	Marking	Mass (g)	EPPL	Packing
HCC4035BD	9306/018/08 or 09			DIL-16		930601808 or 09	2.20	-	
HCC4040BK	9204/026/01 or 02			Flat-16		920402601 or 02	0.70	Y	
HCC4040BD	9204/026/08 or 09			DIL-16		920402608 or 09	2.20	-	
HCC4041UBK	9202/040/01 or 02			Flat-14		920204001 or 02	0.70	-	
HCC4041UBD	9202/040/03 or 04			DIL-14		920204003 or 04	2.20	-	
HCC4042BK	9202/041/01 or 02			Flat-16		920204101 or 02	0.70	-	
HCC4042BD	9202/041/08 or 09			DIL-16		920204108 or 09	2.20	-	
HCC4043BK	9202/042/01 or 02			Flat-16		920204201 or 02	0.70	-	
HCC4043BD	9202/042/08 or 09			DIL-16		920204208 or 09	2.20	-	
HCC4044BK	9202/043/01 or 02			Flat-16		920204301 or 02	0.70	-	
HCC4044BD	9202/043/08 or 09			DIL-16		920204308 or 09	2.20	-	
HCC4046BK	9202/044/01 or 02			Flat-16		920204401 or 02	0.70	-	
HCC4046BD	9202/044/08 or 09			DIL-16	Gold or solder dip	920204408 or 09	2.20	-	Strip pack
HCC4047BK	9207/003/01 or 02	ESCC flight	Specify ESCC variant number in PO	Flat-14		920700301 or 02	0.70	Y	
HCC4047BD	9207/003/03 or 04			DIL-14		920700303 or 04	2.20	-	
HCC4049UBK	9202/045/01 or 02			Flat-16		920204501 or 02	0.70	Y	
HCC4049UBD	9202/045/08 or 09			DIL-16		920204508 or 09	2.20	-	
HCC4050BK	9202/046/01 or 02			Flat-16		920204601 or 02	0.70	Y	
HCC4050BD	9202/046/08 or 09			DIL-16		920204608 or 09	2.20	-	
HCC4051BK	9202/047/01 or 02			Flat-16		920204701 or 02	0.70	Y	
HCC4051BD	9202/047/08 or 09			DIL-16		920204708 or 09	2.20	-	
HCC4052BK	9202/048/01 or 02			Flat-16		920204801 or 02	0.70	-	
HCC4052BD	9202/048/08 or 09			DIL-16		920204808 or 09	2.20	-	
HCC4053BK	9202/049/01 or 02			Flat-16		920204901 or 02	0.70	-	
HCC4053BD	9202/049/08 or 09			DIL-16		920204908 or 09	2.20	-	



Table 10. Ordering information (continued)

Order code	ESCC detailed specification	Quality level	Comment	Package	Lead finish	Marking	Mass (g)	EPPL	Packing
HCC4060BK	9204/052/01 or 02	ESCC flight	Specify ESCC variant number in PO	Flat-16	Gold or solder dip	920405201 or 02	0.70	-	Strip pack
HCC4060BD	9204/052/08 or 09			DIL-16		920405208 or 09	2.20	-	
HCC4063BK	9209/001/01 or 02			Flat-16		920900101 or 02	0.70	Y	
HCC4063BD	9209/001/08 or 09			DIL-16		920900108 or 09	2.20	-	
HCC4066BK	9408/005/01 or 02			Flat-14		940800501 or 02	0.70	Y	
HCC4066BD	9408/005/03 or 04			DIL-14		940800503 or 04	2.20	-	
HCC4067BK	9408/009/01 or 02			Flat-24		940800901 or 02	1.70	-	
HCC4067BD	9408/009/03 or 04			DIL-24		940800903 or 04	5.20	-	
HCC4068BK	9201/061/01 or 02			Flat-14		920106101 or 02	0.70	-	
HCC4068BD	9201/061/03 or 04			DIL-14		920106103 or 04	2.20	-	
HCC4069UBK	9401/010/01 or 02			Flat-14		940101001 or 02	0.70	Y	
HCC4069UBD	9401/010/03 or 04			DIL-14		940101003 or 04	2.20	-	
HCC4070BK	9201/048/01 or 02			Flat-14		920104801 or 02	0.70	-	
HCC4070BD	9201/048/03 or 04			DIL-14		920104803 or 04	2.20	-	
HCC4071BK	9201/063/01 or 02			Flat-14		920106301 or 02	0.70	Y	
HCC4071BD	9201/063/03 or 04			DIL-14		920106303 or 04	2.20	-	
HCC4072BK	9201/082/01 or 02			Flat-14		920108201 or 02	0.70	-	
HCC4072BD	9201/082/03 or 04			DIL-14		920108203 or 04	2.20	-	
HCC4073BK	9201/064/01 or 02			Flat-14		920106401 or 02	0.70	Y	
HCC4073BD	9201/064/03 or 04			DIL-14		920106403 or 04	2.20	-	
HCC4075BK	9201/065/01 or 02	Flat-14	920106501 or 02	0.70	-				
HCC4075BD	9201/065/03 or 04	DIL-14	920106503 or 04	2.20	-				
HCC4076BK	9306/022/01 or 02	Flat-16	930602201 or 02	0.70	Y				
HCC4076BD	9306/022/08 or 09	DIL-16	930602208 or 09	2.20	-				
HCC4077BK	9201/055/01 or 02	Flat-14	920105501 or 02	0.70	-				



Table 10. Ordering information (continued)

Order code	ESCC detailed specification	Quality level	Comment	Package	Lead finish	Marking	Mass (g)	EPPL	Packing
HCC4077BD	9201/055/03 or 04	ESCC flight	Specify ESCC variant number in PO	DIL-14	Gold or solder dip	920105503 or 04	2.20	-	Strip pack
HCC4078BK	9201/062/01 or 02			Flat-14		920106201 or 02	0.70	-	
HCC4078BD	9201/062/03 or 04			DIL-14		920106203 or 04	2.20	-	
HCC4081BK	9201/052/01 or 02			Flat-14		920105201 or 02	0.70	Y	
HCC4081BD	9201/052/03 or 04			DIL-14		920105203 or 04	2.20	-	
HCC4082BK	9201/066/01 or 02			Flat-14		920106601 or 02	0.70	-	
HCC4082BD	9201/066/03 or 04			DIL-14		920106603 or 04	2.20	-	
HCC4093BK	9409/002/01 or 02			Flat-14		940900201 or 02	0.70	Y	
HCC4093BD	9409/002/03 or 04			DIL-14		940900203 or 04	2.20	-	
HCC4094BK	9306/026/01 or 02			Flat-16		930602601 or 02	0.70	Y	
HCC4094BD	9306/026/08 or 09			DIL-16		930602608 or 09	2.20	-	
HCC4098BK	9206/003/01 or 02			Flat-16		920600301 or 02	0.70	Y	
HCC4098BD	9206/003/08 or 09			DIL-16		920600308 or 09	2.20	-	
HCC4099BK	9202/058/01 or 02			Flat-16		920205801 or 02	0.70	Y	
HCC4099BD	9202/058/08 or 09			DIL-16		920205808 or 09	2.20	-	
HCC40103BK	9204/036/01 or 02			Flat-16		920403601 or 02	0.70	Y	
HCC40103BD	9204/036/08 or 09			DIL-16		920403608 or 09	2.20	-	
HCC40106BK	9409/005/01 or 02			Flat-14		940900501 or 02	0.70	Y	
HCC40106BD	9409/005/03 or 04			DIL-14		940900503 or 04	2.20	-	
HCC40107BK	9401/013/01 or 02			Flat-14		940101301 or 02	0.70	Y	
HCC40107BD	9401/013/03 or 04	DIL-14	940101303 or 04	2.20	-				
HCC40109BK	9407/003/01 or 02	Flat-16	940700301 or 02	0.70	Y				
HCC40109BD	9407/003/08 or 09	DIL-16	940700308 or 09	2.20	-				



Table 10. Ordering information (continued)

Order code	ESCC detailed specification	Quality level	Comment	Package	Lead finish	Marking	Mass (g)	EPPL	Packing
HCC40161BK	9204/054/01 or 02			Flat-16		920405401 or 02	0.70	Y	
HCC40161BD	9204/054/08 or 09			DIL-16		920405408 or 09	2.20	-	
HCC40174BK	9203/038/01 or 02			Flat-16		920303801 or 02	0.70	Y	
HCC40174BD	9203/038/08 or 09			DIL-16		920303808 or 09	2.20	-	
HCC40193BK	9204/041/01 or 02			Flat-16		920404101 or 02	0.70	-	
HCC40193BD	9204/041/08 or 09			DIL-16		920404108 or 09	2.20	-	
HCC4502BK	9401/006/01 or 02			Flat-16		940100601 or 02	0.70	Y	
HCC4502BD	9401/006/08 or 09			DIL-16		940100608 or 09	2.20	-	
HCC4503BK	9401/030/01 or 02			Flat-16		940103001 or 02	0.70	Y	
HCC4503BD	9401/030/08 or 09			DIL-16		940103008 or 09	2.20	-	
HCC4508BK	9202/063/01 or 02			Flat-24		920206301 or 02	1.70	Y	
HCC4508BD	9202/063/03 or 04			DIL-24		920206303 or 04	5.20	-	
HCC4512BK	9408/006/01 or 02	ESCC flight	Specify ESCC variant number in PO	Flat-16	Gold or solder dip	940800601 or 02	0.70	Y	Strip pack
HCC4512BD	9408/006/08 or 09			DIL-16		940800608 or 09	2.20	-	
HCC4514BK	9408/012/01 or 02			Flat-24		940801201 or 02	1.70	-	
HCC4514BD	9408/012/03 or 04			DIL-24		940801203 or 04	5.20	-	
HCC4515BK	9205/011/01 or 02			Flat-24		920501101 or 02	1.70	-	
HCC4515BD	9205/011/03 or 04			DIL-24		920501103 or 04	5.20	-	
HCC4516BK	9204/045/01 or 02			Flat-16		920404501 or 02	0.70	-	
HCC4516BD	9204/045/08 or 09			DIL-16		920404508 or 09	2.20	-	
HCC4520BK	9204/028/01 or 02			Flat-16		920402801 or 02	0.70	-	
HCC4520BD	9204/028/08 or 09			DIL-16		920402808 or 09	2.20	-	
HCC4532BK	9202/065/01 or 02			Flat-16		920206501 or 02	0.70	-	
HCC4532BD	9202/065/08 or 09			DIL-16		920206508 or 09	2.20	-	
HCC4538BK	9207/007/01 or 02			Flat-16		920700701 or 02	0.70	-	



**Table 10. Ordering information (continued)**

Order code	ESCC detailed specification	Quality level	Comment	Package	Lead finish	Marking	Mass (g)	EPPL	Packing
HCC4538BD	9207/007/08 or 09	ESCC flight	Specify ESCC variant number in PO	DIL-16	Gold or solder dip	920700708 or 09	2.20	-	Strip pack
HCC4555BK	9408/011/01 or 02			Flat-16		940801101 or 02	0.70	Y	
HCC4555BD	9408/011/08 or 09			DIL-16		940801108 or 09	2.20	-	
HCC4556BK	9408/025/01 or 02			Flat-16		940802501 or 02	0.70	-	
HCC4556BD	9408/025/08 or 09			DIL-16		940802508 or 09	2.20	-	

*Note:* Contact ST sales office for information about the specific conditions for other CMOS4000 part numbers and product in die form



## 6 Revision history

**Table 11. Document revision history**

Date	Revision	Changes
24-Mar-2010	1	First release
29-Mar-2010	2	Updated coverpage description
10-Aug-2011	3	Added <i>Note: on page 10</i> , <i>Note: on page 11</i> , <i>Note: on page 12</i> , <i>Note: on page 13</i> , <i>Note: on page 14</i> , <i>Note: on page 15</i> and in the “Pin connections” diagram on the coverpage.

**Please Read Carefully:**

Information in this document is provided solely in connection with ST products. STMicroelectronics NV and its subsidiaries ("ST") reserve the right to make changes, corrections, modifications or improvements, to this document, and the products and services described herein at any time, without notice.

All ST products are sold pursuant to ST's terms and conditions of sale.

Purchasers are solely responsible for the choice, selection and use of the ST products and services described herein, and ST assumes no liability whatsoever relating to the choice, selection or use of the ST products and services described herein.

No license, express or implied, by estoppel or otherwise, to any intellectual property rights is granted under this document. If any part of this document refers to any third party products or services it shall not be deemed a license grant by ST for the use of such third party products or services, or any intellectual property contained therein or considered as a warranty covering the use in any manner whatsoever of such third party products or services or any intellectual property contained therein.

**UNLESS OTHERWISE SET FORTH IN ST'S TERMS AND CONDITIONS OF SALE ST DISCLAIMS ANY EXPRESS OR IMPLIED WARRANTY WITH RESPECT TO THE USE AND/OR SALE OF ST PRODUCTS INCLUDING WITHOUT LIMITATION IMPLIED WARRANTIES OF MERCHANTABILITY, FITNESS FOR A PARTICULAR PURPOSE (AND THEIR EQUIVALENTS UNDER THE LAWS OF ANY JURISDICTION), OR INFRINGEMENT OF ANY PATENT, COPYRIGHT OR OTHER INTELLECTUAL PROPERTY RIGHT.**

**UNLESS EXPRESSLY APPROVED IN WRITING BY TWO AUTHORIZED ST REPRESENTATIVES, ST PRODUCTS ARE NOT RECOMMENDED, AUTHORIZED OR WARRANTED FOR USE IN MILITARY, AIR CRAFT, SPACE, LIFE SAVING, OR LIFE SUSTAINING APPLICATIONS, NOR IN PRODUCTS OR SYSTEMS WHERE FAILURE OR MALFUNCTION MAY RESULT IN PERSONAL INJURY, DEATH, OR SEVERE PROPERTY OR ENVIRONMENTAL DAMAGE. ST PRODUCTS WHICH ARE NOT SPECIFIED AS "AUTOMOTIVE GRADE" MAY ONLY BE USED IN AUTOMOTIVE APPLICATIONS AT USER'S OWN RISK.**

Resale of ST products with provisions different from the statements and/or technical features set forth in this document shall immediately void any warranty granted by ST for the ST product or service described herein and shall not create or extend in any manner whatsoever, any liability of ST.

ST and the ST logo are trademarks or registered trademarks of ST in various countries.

Information in this document supersedes and replaces all information previously supplied.

The ST logo is a registered trademark of STMicroelectronics. All other names are the property of their respective owners.

© 2011 STMicroelectronics - All rights reserved

STMicroelectronics group of companies

Australia - Belgium - Brazil - Canada - China - Czech Republic - Finland - France - Germany - Hong Kong - India - Israel - Italy - Japan - Malaysia - Malta - Morocco - Philippines - Singapore - Spain - Sweden - Switzerland - United Kingdom - United States of America

[www.st.com](http://www.st.com)