

High Power LED Series
3535 Ceramic Hot Binning

LH351B

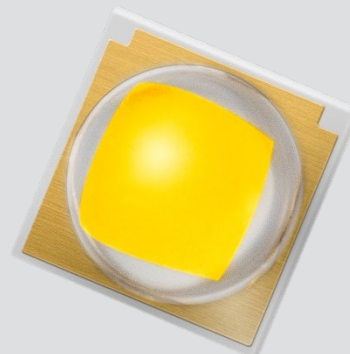

High efficacy and high quality color rendering makes the LH351B suitable use in a broad range of applications

Features & Benefits

- Operates at a maximum current of up to 1.5 A
- Uniform light distribution under any beam angle
- 80 CRI makes it well suited for most applications
- Hot binning @ 85 °C
- Completed 10,000 hours of LM-80 testing @ 1 A, 105 °C

Applications

- Indoor Lighting: Spotlight, Downlight
- Outdoor Lighting: Street Light, Tunnel Light, Security Light, Parking Lot Light
- Industrial Lighting: High Bay Light, Low Bay Light
- Consumer Lighting: Torch Light



SAMSUNG

Table of Contents

1.	Characteristics	-----	3
2.	Product Code Information	-----	7
3.	Typical Characteristics Graphs	-----	21
4.	Outline Drawing & Dimension	-----	23
5.	Reliability Test Items & Conditions	-----	24
6.	Soldering Conditions	-----	25
7.	Tape & Reel	-----	26
8.	Label Structure	-----	28
9.	Packing Structure	-----	29
10.	Precautions in Handling & Use	-----	31

1. Characteristics

a) Absolute Maximum Rating

Item	Symbol	Rating	Unit	Condition
Operating Temperature	T_{opr}	-40 ~ +105	°C	Note 1)*
Storage Temperature	T_{stg}	-40 ~ +120	°C	-
LED Junction Temperature	T_j	150	°C	-
Forward Current	I_F	1500	mA	-
Peak Pulse Forward Current	I_{FP}	2000	mA	Duty 1/10 pulse width 10ms
Assembly Process Temperature		260 <10	°C s	-
ESD (HBM)	-	±8	kV	-

Notes:

- 1) Refer to the derating curve, '3. Typical Characteristics Graph', for proper driving current that maintained below maximum junction temperature.

b) Electro-optical Characteristics

Item	Unit	Nominal CCT (K)	Condition		Value Typ.
			I _F (mA)	T _J (°C)	
Luminous Flux (Φ _v)	lm	3000 (80 CRI)	350	25	149
			350	85	136
			700	85	249
			1000	85	332
			1500	85	446
		5000 (70 CRI)	350	25	175
			350	85	160
			700	85	292
			1000	85	391
			1500	85	525
Forward Voltage (V _F)	V		350	25	2.86
			350	85	2.75
			700	85	2.89
			1000	85	2.99
			1500	85	3.12
Reverse Voltage (@ 5 mA)	V		350	25	14~19.5
Thermal Resistance (junction to solder point)	°C/W		350	25	4
Beam Angle	°		350	25	120

Notes:

- 1) Samsung maintains measurement tolerance of: luminous flux = ±7 %, forward voltage = ±0.1 V
- 2) Characteristics @ 25 °C are for reference only

c) Luminous Flux Characteristics (T_j = 85 °C)

Nominal CCT (K)	CRI (R _a) Min. ¹⁾	Sorting @ 350 mA (lm)		Calculated Minimum Flux ²⁾ (lm)		
		Flux Rank	Flux Min. ¹⁾	@ 700 mA	@ 1000 mA	@ 1500 mA
2200	70	J3	120	217	286	386
		(K3)	(132)	(238)	(314)	(424)
	80	G3	100	181	238	322
		(H3)	(110)	(199)	(262)	(353)
2700	70	K3	130	235	310	418
		(M3)	(143)	(258)	(340)	(460)
		M3	140	252	335	457
		(N3)	(153)	(276)	(366)	(499)
	80	N3	150	270	359	489
		(P3)	(164)	(295)	(392)	(534)
	90	J3	120	217	286	386
		(K3)	(132)	(238)	(314)	(424)
		K3	130	235	310	418
		(M3)	(143)	(258)	(340)	(460)
F3		90	163	214	289	
(G3)		(99)	(179)	(236)	(318)	
3000	70	G3	100	181	238	322
		(H3)	(110)	(199)	(262)	(353)
		M3	140	252	335	457
		(N3)	(153)	(276)	(366)	(499)
	80	N3	150	270	359	489
		(P3)	(164)	(295)	(392)	(534)
	90	J3	120	217	286	386
		(K3)	(132)	(238)	(314)	(424)
		K3	130	234	311	424
		(M3)	(142)	(256)	(340)	(463)
M3		140	252	335	457	
(N3)		(153)	(276)	(366)	(499)	
3500	70	G3	100	181	238	322
		(H3)	(110)	(199)	(262)	(353)
		H3	110	199	262	354
		(I3)	(121)	(218)	(288)	(389)
	80	K3	130	234	311	424
		(M3)	(142)	(256)	(340)	(463)
	90	M3	140	252	335	457
		(N3)	(153)	(276)	(366)	(499)
		N3	150	270	359	489
		(P3)	(164)	(295)	(392)	(534)
K3		130	234	311	424	
(M3)		(142)	(256)	(340)	(463)	
90	M3	140	252	335	457	
	(N3)	(153)	(276)	(366)	(499)	
	G3	100	181	238	322	
	(H3)	(110)	(199)	(262)	(353)	
	H3	110	199	262	354	
	(I3)	(121)	(218)	(288)	(389)	

(value in bracket): Minimum luminous flux @ 25 °C, for reference only

Notes:

- 1) Samsung maintains measurement tolerance of: luminous flux = ±7 %, CRI = ±3
- 2) Calculated minimum flux values are for reference only

c) Luminous Flux Characteristics (T_j = 85 °C)

Nominal CCT (K)	CRI (R _a) Min. ¹⁾	Sorting @ 350 mA (lm)		Calculated Minimum Flux ²⁾ (lm)		
		Flux Rank	Flux Min. ¹⁾	@ 700 mA	@ 1000 mA	@ 1500 mA
4000	70	N3	150	270	359	489
		(P3)	(164)	(295)	(392)	(534)
		P3	160	288	382	518
	80	(Q3)	(174)	(312)	(415)	(562)
		K3	130	235	310	418
		(M3)	(143)	(258)	(340)	(460)
	90	M3	140	252	335	457
		(N3)	(153)	(276)	(366)	(499)
		J3	120	217	286	386
5000	70	(K3)	(132)	(238)	(314)	(424)
		M3	140	252	335	457
		(N3)	(153)	(276)	(366)	(499)
	80	N3	150	270	359	489
		(P3)	(164)	(295)	(392)	(534)
		P3	160	288	382	518
	90	(Q3)	(174)	(312)	(415)	(562)
		Q2	170	306	405	545
		(R2)	(184)	(329)	(437)	(590)
5700	70	M3	140	252	335	457
		(N3)	(153)	(276)	(366)	(499)
		N3	150	270	359	489
	80	(P3)	(164)	(295)	(392)	(534)
		K3	130	234	311	424
		(M3)	(142)	(256)	(340)	(463)
	90	N3	150	270	359	489
		(P3)	(164)	(295)	(392)	(534)
		P3	160	288	382	518
6000K	70	(Q3)	(174)	(312)	(415)	(562)
		M3	140	252	335	457
		(N3)	(153)	(276)	(366)	(499)
	80	K3	130	234	311	424
		(M3)	(142)	(256)	(340)	(463)
		M3	140	252	335	457
	90	(N3)	(153)	(276)	(366)	(499)
		N3	150	270	359	489
		(P3)	(164)	(295)	(392)	(534)
6500	70	P3	160	288	382	518
		(Q3)	(174)	(312)	(415)	(562)
		K3	130	234	311	424
	80	(M3)	(142)	(256)	(340)	(463)
		M3	140	252	335	457
		(N3)	(153)	(276)	(366)	(499)

(value in bracket): Minimum luminous flux @ 25 °C, for reference only

Notes:

- 1) Samsung maintains measurement tolerance of: luminous flux = ±7 %, CRI = ±3
- 2) Calculated minimum flux values are for reference only

2. Product Code Information

1	2	3	4	5	6	7	8	9	10	11	12	13	14	15	16	17	18
S	P	H	W	H	2	L	3	D	3	0	E	D	4	V	0	K	3

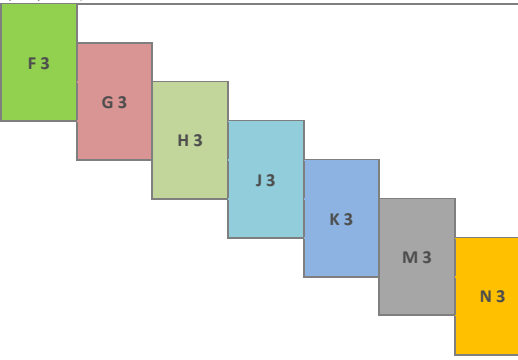
Digit	PKG Information	Code	Specification
1 2 3	Samsung Package High Power	SPH	
4 5	Color	WH	White
6	Product Version	2	
7 8	Product	L3	LH351 Series
9	Lens Type	D	Dome lens
10	Internal Code	3	
11	Not Defined	0	Default
12	CRI & Sorting Temperature	C D E F G	Min. 70 Min. 75 Min. 80 85°C Min. 85 Min. 90
13 14	Forward Voltage (V)	D 4	2.5~3.0 Bin Code: D2 2.5~2.8 F2 2.8~3.0
15 16	CCT (K)	Y☆ W☆ V☆ U☆ T☆ R◇ Q◇ PQ P◇	2200 Y1, Y2, Y3, Y4, Y5, Y6, Y7, Y8, Y9, YA, YB, YC, YD, YE, YF, YG, YM 2700 W1, W2, W3, W4, W5, W6, W7, W8, W9, WA, WB, WC, WD, WE, WF, WG, WM 3000 V1, V2, V3, V4, V5, V6, V7, V8, V9, VA, VB, VC, VD, VE, VF, VG, VM 3500 U1, U2, U3, U4, U5, U6, U7, U8, U9, UA, UB, UC, UD, UE, UF, UG, UM 4000 Bin Code: T1, T2, T3, T4, T5, T6, T7, T8, T9, TA, TB, TC, TD, TE, TF, TG, TM 5000 R1, R2, R3, R4 5700 Q1, Q2, Q3, Q4 6000 P2, Q1, P4, Q3 6500 P1, P2, P3, P4 ☆ : "0" (Whole bin), "P" (Quarter bin), or "M" (MacAdam 3-step ellipse bin) ◇ : "T" (Half bin), or "N" (MacAdam 5-step ellipse bin)
17 18	Luminous Flux (lm)	F3 G3 H3 J3 K3 M3 N3 P3 Q2	90~120 F1 90~100 100~130 G1 100~110 110~140 H1 110~120 120~150 J1 120~130 130~160 K1 130~140 140~170 M1 140~150 150~180 N1 150~160 160~190 P1 160~170 170~190 Q1 170~180 R1 180~190 
			Digit 17: Min. spec. Digit 18: The number of higher bin(s) from min. spec. e.g.: K1 = 130~140 lm, K3 = 130~160 lm

a) Luminous Flux Bins ($I_f = 350 \text{ mA}$, $T_j = 85 \text{ }^\circ\text{C}$)

Nominal CCT (K)	CRI (R _a) Min.	Product Code	Flux Rank	Flux Bin	Flux Range (Φ _v , lm)
2200	70	SPHWH2L3D30CD4Y☆J3	J3	J1	120 ~ 130
				K1	130 ~ 140
				M1	140 ~ 150
	80	SPHWH2L3D30ED4Y☆G3	G3	G1	100 ~ 110
				H1	110 ~ 120
				J1	120 ~ 130
2700	70	SPHWH2L3D30CD4W☆K3	K3	K1	130 ~ 140
				M1	140 ~ 150
				N1	150 ~ 160
		SPHWH2L3D30CD4W☆M3	M3	M1	140 ~ 150
				N1	150 ~ 160
				P1	160 ~ 170
	SPHWH2L3D30CD4W☆N3	N3	N1	150 ~ 160	
			P1	160 ~ 170	
			Q1	170 ~ 180	
	80	SPHWH2L3D30ED4W☆J3	J3	J1	120 ~ 130
				K1	130 ~ 140
				M1	140 ~ 150
SPHWH2L3D30ED4W☆K3		K3	K1	130 ~ 140	
			M1	140 ~ 150	
			N1	150 ~ 160	
90	SPHWH2L3D30GD4W☆F3	F3	F1	90 ~ 100	
			G1	100 ~ 110	
			H1	110 ~ 120	
	SPHWH2L3D30GD4W☆G3	G3	G1	100 ~ 110	
			H1	110 ~ 120	
			J1	120 ~ 130	
70	SPHWH2L3D30CD4V☆M3	M3	M1	140 ~ 150	
			N1	150 ~ 160	
			P1	160 ~ 170	
	SPHWH2L3D30CD4V☆N3	N3	N1	150 ~ 160	
			P1	160 ~ 170	
			Q1	170 ~ 180	
3000	SPHWH2L3D30ED4V☆J3	J3	J1	120 ~ 130	
			K1	130 ~ 140	
			M1	140 ~ 150	
	80	SPHWH2L3D30ED4V☆K3	K3	K1	130 ~ 140
				M1	140 ~ 150
				N1	150 ~ 160
SPHWH2L3D30ED4V☆M3	M3	M1	140 ~ 150		
		N1	150 ~ 160		
		P1	160 ~ 170		

"☆" can be "0" (Whole bin), "P" (Quarter bin), or "M" (MacAdam 3-step ellipse bin) of the color binning

"◇" can be "T" (Half bin), or "N" (MacAdam 5-step ellipse bin) of the color binning

a) Luminous Flux Bins ($I_f = 350 \text{ mA}$, $T_j = 85 \text{ }^\circ\text{C}$)

Nominal CCT (K)	CRI (R _a) Min.	Product Code	Flux Rank	Flux Bin	Flux Range (Φ _v , lm)
3000	90	SPHWH2L3D30GD4V ☆ G3	G3	G1	100 ~ 110
				H1	110 ~ 120
				J1	120 ~ 130
		SPHWH2L3D30GD4V ☆ H3	H3	H1	110 ~ 120
				J1	120 ~ 130
				K1	130 ~ 140
	70	SPHWH2L3D30CD4U ☆ K3	K3	K1	130 ~ 140
				M1	140 ~ 150
				N1	150 ~ 160
		SPHWH2L3D30CD4U ☆ M3	M3	M1	140 ~ 150
				N1	150 ~ 160
				P1	160 ~ 170
3500	80	SPHWH2L3D30CD4U ☆ N3	N3	N1	150 ~ 160
				P1	160 ~ 170
				Q1	170 ~ 180
		SPHWH2L3D30ED4U ☆ K3	K3	K1	130 ~ 140
				M1	140 ~ 150
				N1	150 ~ 160
	SPHWH2L3D30ED4U ☆ M3	M3	M1	140 ~ 150	
			N1	150 ~ 160	
			P1	160 ~ 170	
	90	SPHWH2L3D30GD4U ☆ G3	G3	G1	100 ~ 110
				H1	110 ~ 120
				J1	120 ~ 130
SPHWH2L3D30GD4U ☆ H3		H3	H1	110 ~ 120	
			J1	120 ~ 130	
			K1	130 ~ 140	
4000	70	SPHWH2L3D30CD4T ☆ N3	N3	N1	150 ~ 160
				P1	160 ~ 170
				Q1	170 ~ 180
	SPHWH2L3D30CD4T ☆ P3	P3	P1	160 ~ 170	
			Q1	170 ~ 180	
			R1	180 ~ 190	

"☆" can be "0" (Whole bin), "P" (Quarter bin), or "M" (MacAdam 3-step ellipse bin) of the color binning

"◇" can be "T" (Half bin), or "N" (MacAdam 5-step ellipse bin) of the color binning

a) Luminous Flux Bins ($I_f = 350 \text{ mA}$, $T_j = 85 \text{ }^\circ\text{C}$)

Nominal CCT (K)	CRI (R _a) Min.	Product Code	Flux Rank	Flux Bin	Flux Range (Φ_v , lm)
4000	80	SPHWH2L3D30ED4T☆K3	K3	K1	130 ~ 140
				M1	140 ~ 150
				N1	150 ~ 160
		SPHWH2L3D30ED4T☆M3	M3	M1	140 ~ 150
				N1	150 ~ 160
				P1	160 ~ 170
	90	SPHWH2L3D30GD4T0J3	J3	J1	120 ~ 130
				K1	130 ~ 140
				M1	140 ~ 150
		SPHWH2L3D30GD4TPJ3	J3	J1	120 ~ 130
				K1	130 ~ 140
				M1	140 ~ 150
5000	70	SPHWH2L3D30CD4R◇M3	M3	M1	140 ~ 150
				N1	150 ~ 160
				P1	160 ~ 170
		SPHWH2L3D30CD4R◇N3	N3	N1	150 ~ 160
				P1	160 ~ 170
				Q1	170 ~ 180
	SPHWH2L3D30CD4R◇P3	P3	P1	160 ~ 170	
			Q1	170 ~ 180	
			R1	180 ~ 190	
	80	SPHWH2L3D30CD4R◇Q2	Q2	Q1	170 ~ 180
				R1	180 ~ 190
				M1	140 ~ 150
SPHWH2L3D30ED4R◇M3		M3	N1	150 ~ 160	
			P1	160 ~ 170	
			N1	150 ~ 160	
SPHWH2L3D30ED4R◇N3	N3	P1	160 ~ 170		
		Q1	170 ~ 180		
		K1	130 ~ 140		
90	SPHWH2L3D30GD4R◇K3	K3	M1	140 ~ 150	
			N1	150 ~ 160	

"☆" can be "0" (Whole bin), "P" (Quarter bin), or "M" (MacAdam 3-step ellipse bin) of the color binning

"◇" can be "T" (Half bin), or "N" (MacAdam 5-step ellipse bin) of the color binning

a) Luminous Flux Bins ($I_f = 350 \text{ mA}$, $T_j = 85 \text{ }^\circ\text{C}$)

Nominal CCT (K)	CRI (R_a) Min.	Product Code	Flux Rank	Flux Bin	Flux Range (Φ_v , lm)
5700	70	SPHWH2L3D30CD4Q◇N3	N3	N1	150 ~ 160
				P1	160 ~ 170
				Q1	170 ~ 180
	80	SPHWH2L3D30ED4Q◇M3	M3	P1	160 ~ 170
				Q1	170 ~ 180
				R1	180 ~ 190
6000	80	SPHWH2L3D30ED4PQK3	K3	M1	140 ~ 150
				N1	150 ~ 160
				P1	160 ~ 170
	70	SPHWH2L3D30ED4PQM3	M3	N1	150 ~ 160
				P1	160 ~ 170
				R1	180 ~ 190
6500	70	SPHWH2L3D30CD4P◇N3	N3	P1	160 ~ 170
				Q1	170 ~ 180
				R1	180 ~ 190
	80	SPHWH2L3D30ED4P◇K3	K3	K1	130 ~ 140
				M1	140 ~ 150
				N1	150 ~ 160
80	SPHWH2L3D30ED4P◇M3	M3	M1	140 ~ 150	
			N1	150 ~ 160	
			P1	160 ~ 170	

"☆" can be "0" (Whole bin), "P" (Quarter bin), or "M" (MacAdam 3-step ellipse bin) of the color binning

"◇" can be "T" (Half bin), or "N" (MacAdam 5-step ellipse bin) of the color binning

b) Color Bins ($I_F = 350 \text{ mA}$, $T_j = 85 \text{ }^\circ\text{C}$)

Nominal CCT (K)	CRI (R _s) Min.	Product Code	Color Rank	Chromaticity Bins
2200	70	SPHWH2L3D30ED4Y0J3	Y0 (Whole bin)	Y1, Y2, Y3, Y4, Y5, Y6, Y7, Y8, Y9, YA, YB, YC, YD, YE, YF, YG
		SPHWH2L3D30ED4YPJ3	YP (Quarter bin)	Y6, Y7, YA, YB
		SPHWH2L3D30ED4YMJ3	YM (MacAdam 3-step)	YM
	80	SPHWH2L3D30ED4Y0G3	Y0 (Whole bin)	Y1, Y2, Y3, Y4, Y5, Y6, Y7, Y8, Y9, YA, YB, YC, YD, YE, YF, YG
		SPHWH2L3D30ED4YPG3	YP (Quarter bin)	Y6, Y7, YA, YB
		SPHWH2L3D30ED4YMG3	YM (MacAdam 3-step)	YM
2700	70	SPHWH2L3D30CD4W0K3	W0 (Whole bin)	W1, W2, W3, W4, W5, W6, W7, W8, W9, WA, WB, WC, WD, WE, WF, WG
		SPHWH2L3D30CD4W0M3		
		SPHWH2L3D30CD4W0N3		
		SPHWH2L3D30CD4WPK3	WP (Quarter bin)	W6, W7, WA, WB
		SPHWH2L3D30CD4WPM3		
		SPHWH2L3D30CD4WPN3		
	SPHWH2L3D30CD4WMM3	WM (MacAdam 3-step)	WM	
	SPHWH2L3D30CD4WMN3			
	SPHWH2L3D30ED4W0J3			
	80	SPHWH2L3D30ED4W0K3	W0 (Whole bin)	W1, W2, W3, W4, W5, W6, W7, W8, W9, WA, WB, WC, WD, WE, WF, WG
		SPHWH2L3D30ED4WPJ3	WP (Quarter bin)	W6, W7, WA, WB
		SPHWH2L3D30ED4WPK3	WM (MacAdam 3-step)	WM
SPHWH2L3D30ED4WMI3				
SPHWH2L3D30ED4WMM3				
90		SPHWH2L3D30GD4W0F3	W0 (Whole bin)	W1, W2, W3, W4, W5, W6, W7, W8, W9, WA, WB, WC, WD, WE, WF, WG
	SPHWH2L3D30GD4W0G3	WP (Quarter bin)	W6, W7, WA, WB	
	SPHWH2L3D30GD4WPF3			
	SPHWH2L3D30GD4WPG3			
	SPHWH2L3D30GD4WMF3	WM (MacAdam 3-step)	WM	
	SPHWH2L3D30GD4WMM3			
SPHWH2L3D30GD4WMN3				
3000	70	SPHWH2L3D30CD4V0M3	V0 (Whole bin)	V1, V2, V3, V4, V5, V6, V7, V8, V9, VA, VB, VC, VD, VE, VF, VG
		SPHWH2L3D30CD4V0N3		
		SPHWH2L3D30CD4VPM3		
		SPHWH2L3D30CD4VPN3	VP (Quarter bin)	V6, V7, VA, VB
		SPHWH2L3D30CD4VMM3		
		SPHWH2L3D30CD4VMN3		
	80	SPHWH2L3D30ED4V0J3	V0 (Whole bin)	V1, V2, V3, V4, V5, V6, V7, V8, V9, VA, VB, VC, VD, VE, VF, VG
		SPHWH2L3D30ED4V0K3		
		SPHWH2L3D30ED4V0M3		
		SPHWH2L3D30ED4VPJ3	VP (Quarter bin)	V6, V7, VA, VB
		SPHWH2L3D30ED4VPK3		
		SPHWH2L3D30ED4VPM3		
SPHWH2L3D30ED4VMJ3	VM (MacAdam 3-step)	VM		
SPHWH2L3D30ED4VMK3				
SPHWH2L3D30ED4VMM3				

b) Color Bins (I_F = 350 mA, T_J = 85 °C)

Nominal CCT (K)	CRI (R _a) Min.	Product Code	Color Rank	Chromaticity Bins	
3000	90	SPHWH2L3D30GD4V0G3	V0	V1, V2, V3, V4, V5, V6, V7, V8, V9, VA, VB, VC, VD, VE, VF, VG	
		SPHWH2L3D30GD4V0H3	(Whole bin)		
		SPHWH2L3D30GD4VPG3	VP	V6, V7, VA, VB	
		SPHWH2L3D30GD4VPH3	(Quarter bin)		
		SPHWH2L3D30GD4VMG3	VM		
	SPHWH2L3D30GD4VMH3	(MacAdam 3-step)	VM		
	3500	70	SPHWH2L3D30CD4U0K3	U0	U1, U2, U3, U4, U5, U6, U7, U8, U9, UA, UB, UC, UD, UE, UF, UG
			SPHWH2L3D30CD4U0M3	(Whole bin)	
			SPHWH2L3D30CD4U0N3	UP	U6, U7, UA, UB
			SPHWH2L3D30CD4UPK3	(Quarter bin)	
SPHWH2L3D30CD4UPM3			UM		
SPHWH2L3D30CD4UPN3		(MacAdam 3-step)	UM		
3500		80	SPHWH2L3D30ED4U0K3	U0	U1, U2, U3, U4, U5, U6, U7, U8, U9, UA, UB, UC, UD, UE, UF, UG
			SPHWH2L3D30ED4U0M3	(Whole bin)	
			SPHWH2L3D30ED4UPK3	UP	U6, U7, UA, UB
			SPHWH2L3D30ED4UPM3	(Quarter bin)	
	SPHWH2L3D30ED4UMK3		UM		
	SPHWH2L3D30ED4UMM3	(MacAdam 3-step)	UM		
	4000	90	SPHWH2L3D30GD4U0G3	U0	U1, U2, U3, U4, U5, U6, U7, U8, U9, UA, UB, UC, UD, UE, UF, UG
			SPHWH2L3D30GD4U0H3	(Whole bin)	
			SPHWH2L3D30GD4UPG3	UP	U6, U7, UA, UB
			SPHWH2L3D30GD4UPH3	(Quarter bin)	
SPHWH2L3D30GD4UMG3			UM		
SPHWH2L3D30GD4UMH3		(MacAdam 3-step)	UM		
4000		70	SPHWH2L3D30CD4T0N3	T0	T1, T2, T3, T4, T5, T6, T7, T8, T9, TA, TB, TC, TD, TE, TF, TG
			SPHWH2L3D30CD4T0P3	(Whole bin)	
			SPHWH2L3D30CD4TPN3	TP	T6, T7, TA, TB
			SPHWH2L3D30CD4TPP3	(Quarter bin)	
	SPHWH2L3D30CD4TMN3		TM		
	SPHWH2L3D30CD4TMP3	(MacAdam 3-step)	TM		
	4000	80	SPHWH2L3D30ED4T0K3	T0	T1, T2, T3, T4, T5, T6, T7, T8, T9, TA, TB, TC, TD, TE, TF, TG
			SPHWH2L3D30ED4T0M3	(Whole bin)	
			SPHWH2L3D30ED4TPK3	TP	T6, T7, TA, TB
			SPHWH2L3D30ED4TPM3	(Quarter bin)	
SPHWH2L3D30ED4TMK3			TM		
SPHWH2L3D30ED4TMM3		(MacAdam 3-step)	TM		
90		SPHWH2L3D30GD4T0J3	T0	T1, T2, T3, T4, T5, T6, T7, T8, T9, TA, TB, TC, TD, TE, TF, TG	
		SPHWH2L3D30GD4TPJ3	(Whole bin)		
			SPHWH2L3D30GD4TPJ3	TP	T6, T7, TA, TB
				(Quarter bin)	

b) Color Bins (I_F = 350 mA, T_J = 85 °C)

Nominal CCT (K)	CRI (R _a) Min.	Product Code	Color Rank	Chromaticity Bins
5000	70	SPHWH2L3D30CD4RTM3	RT (Half bin)	R1, R2, R3, R4
		SPHWH2L3D30CD4RTN3		
		SPHWH2L3D30CD4RTP3		
		SPHWH2L3D30CD4RTQ2		
		SPHWH2L3D30CD4RNM3		
		SPHWH2L3D30CD4RNN3		
	80	SPHWH2L3D30CD4RNP3	RN (MacAdam 5-step)	RN
		SPHWH2L3D30CD4RNQ2		
		SPHWH2L3D30ED4RTM3	RT (Half bin)	R1, R2, R3, R4
		SPHWH2L3D30ED4RTN3		
		SPHWH2L3D30ED4RNM3	RN (MacAdam 5-step)	RN
		SPHWH2L3D30ED4RNN3		
5700	90	SPHWH2L3D30GD4RTK3	RT (Half bin)	R1, R2, R3, R4
		SPHWH2L3D30GD4RNM3	RN (MacAdam 5-step)	RN
		SPHWH2L3D30GD4RNN3		
	70	SPHWH2L3D30CD4QTN3	QT (Half bin)	Q1, Q2, Q3, Q4
		SPHWH2L3D30CD4QTP3		
		SPHWH2L3D30CD4QNN3	QN (MacAdam 5-step)	QN
80	SPHWH2L3D30CD4QNP3			
	SPHWH2L3D30ED4QTM3	QT (Half bin)	Q1, Q2, Q3, Q4	
	SPHWH2L3D30ED4QNM3	QN (MacAdam 5-step)	QN	
6000	80	SPHWH2L3D30ED4PQK3	PQ (Half bin)	Q1, Q3, P2, P4
		SPHWH2L3D30ED4PQM3		
	70	SPHWH2L3D30CD4PTN3	PT (Half bin)	P1, P2, P3, P4
		SPHWH2L3D30CD4PTP3		
		SPHWH2L3D30CD4PNN3	PN	PN
		SPHWH2L3D30CD4PNP3	(MacAdam 5-step)	
6500	80	SPHWH2L3D30ED4PTK3	PT (Half bin)	P1, P2, P3, P4
		SPHWH2L3D30ED4PTM3		
		SPHWH2L3D30ED4PNK3	PN	PN
		SPHWH2L3D30ED4PNM3	(MacAdam 5-step)	

c) Voltage Bins ($I_f = 350 \text{ mA}$, $T_j = 85 \text{ }^\circ\text{C}$)

Nominal CCT (K)	CRI (R _a) Min.	Product Code	Voltage Rank	Voltage Bin	Voltage Range (V)
-	-	-	D4	D2	2.5 ~ 2.8
				F2	2.8 ~ 3.0

d) Chromaticity Region & Coordinates ($I_f = 350 \text{ mA}$, $T_j = 85 \text{ }^\circ\text{C}$)

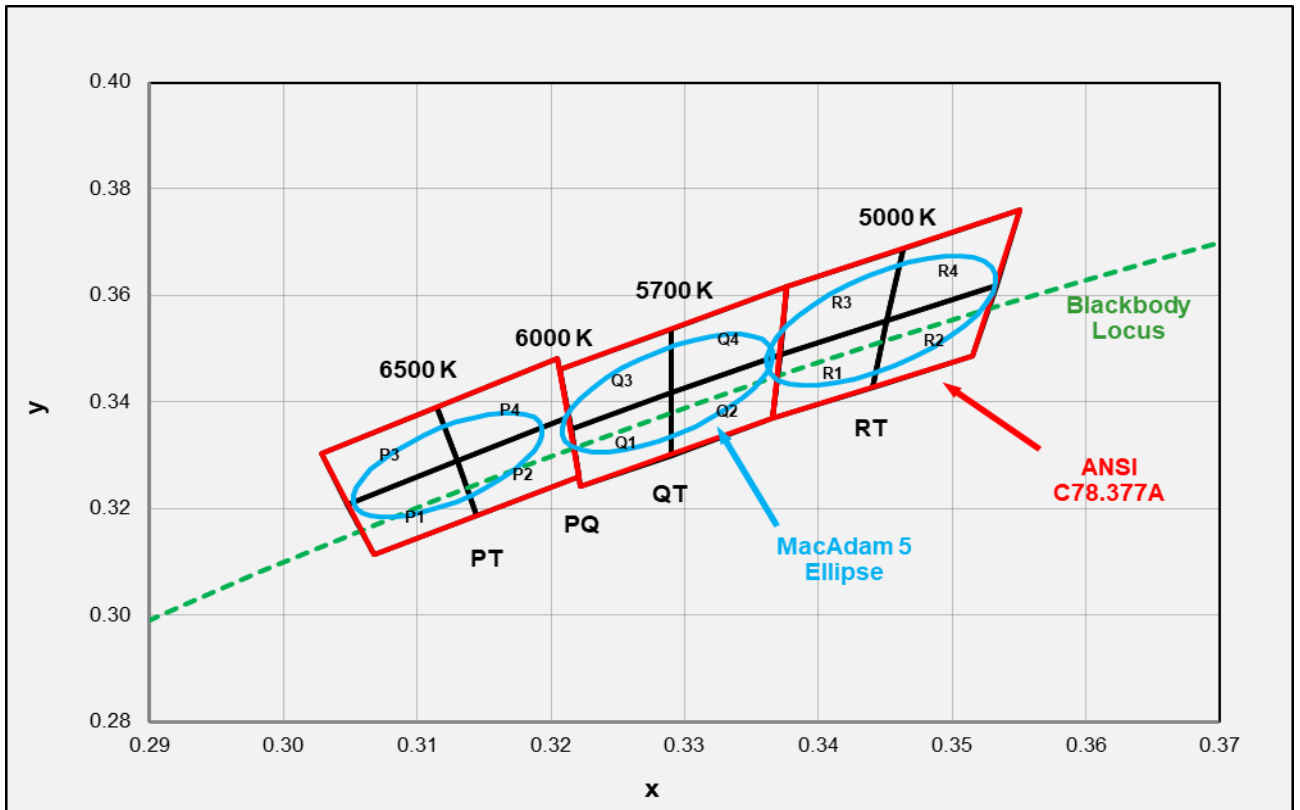
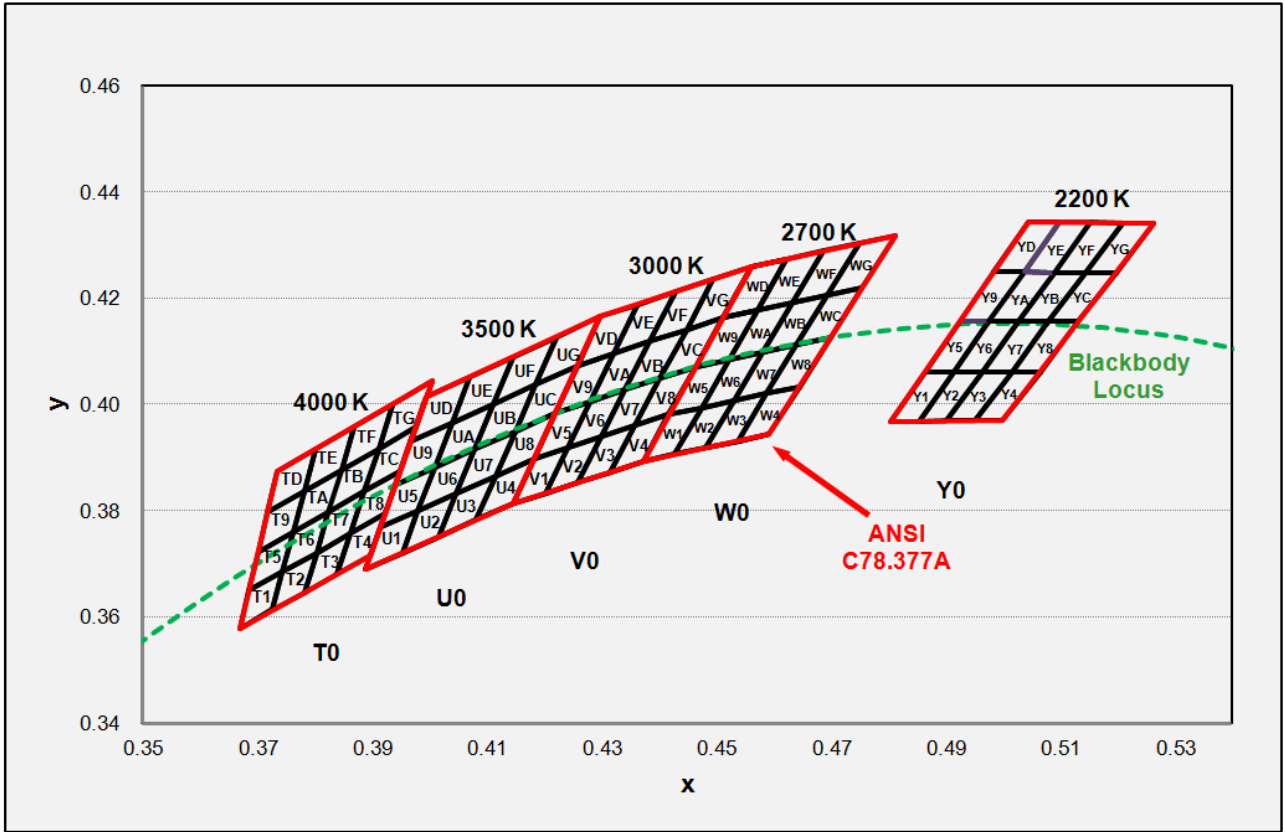

d) Chromaticity Region & Coordinates ($I_f = 350 \text{ mA}$, $T_j = 85 \text{ }^\circ\text{C}$)

Region	CIE x	CIE y	Region	CIE x	CIE y
Y rank (2200 K)					
Y1	0.4805	0.3968	Y9	0.4925	0.4156
	0.4854	0.3968		0.4976	0.4156
	0.4915	0.4062		0.5038	0.4250
	0.4865	0.4062		0.4984	0.4250
Y2	0.4854	0.3968	YA	0.4976	0.4156
	0.4903	0.3969		0.5028	0.4156
	0.4966	0.4062		0.5091	0.4249
	0.4915	0.4062		0.5038	0.4250
Y3	0.4903	0.3969	YB	0.5028	0.4156
	0.4952	0.3969		0.5080	0.4156
	0.5016	0.4062		0.5145	0.4249
	0.4966	0.4062		0.5091	0.4249
Y4	0.4952	0.3969	YC	0.5080	0.4156
	0.5000	0.3969		0.5132	0.4156
	0.5066	0.4062		0.5198	0.4249
	0.5016	0.4062		0.5145	0.4249
Y5	0.4865	0.4062	YD	0.4984	0.4250
	0.4915	0.4062		0.5038	0.4250
	0.4976	0.4156		0.5099	0.4344
	0.4925	0.4156		0.5044	0.4344
Y6	0.4915	0.4062	YE	0.5038	0.4250
	0.4966	0.4062		0.5091	0.4249
	0.5028	0.4156		0.5154	0.4343
	0.4976	0.4156		0.5099	0.4344
Y7	0.4966	0.4062	YF	0.5091	0.4249
	0.5016	0.4062		0.5145	0.4249
	0.508	0.4156		0.5209	0.4342
	0.5028	0.4156		0.5154	0.4343
Y8	0.5016	0.4062	YG	0.5145	0.4249
	0.5066	0.4062		0.5198	0.4249
	0.5132	0.4156		0.5264	0.4342
	0.5080	0.4156		0.5209	0.4342

Region	CIE x	CIE y	Region	CIE x	CIE y
W rank (2700 K)					
W1	0.4373	0.3893	W9	0.4465	0.4071
	0.4418	0.3981		0.4513	0.4164
	0.4475	0.3994		0.4573	0.4178
	0.4428	0.3906		0.4523	0.4085
W2	0.4428	0.3906	WA	0.4523	0.4085
	0.4475	0.3994		0.4573	0.4178
	0.4532	0.4008		0.4634	0.4193
	0.4483	0.3919		0.4582	0.4099
W3	0.4483	0.3919	WB	0.4582	0.4099
	0.4532	0.4008		0.4634	0.4193
	0.4589	0.4021		0.4695	0.4207
	0.4538	0.3931		0.4641	0.4112
W4	0.4538	0.3931	WC	0.4641	0.4112
	0.4589	0.4021		0.4695	0.4207
	0.4646	0.4034		0.4756	0.4221
	0.4593	0.3944		0.4700	0.4126
W5	0.4418	0.3981	WD	0.4513	0.4164
	0.4465	0.4071		0.4562	0.4260
	0.4523	0.4085		0.4624	0.4274
	0.4475	0.3994		0.4573	0.4178
W6	0.4475	0.3994	WE	0.4573	0.4178
	0.4523	0.4085		0.4624	0.4274
	0.4582	0.4099		0.4687	0.4289
	0.4532	0.4008		0.4634	0.4193
W7	0.4532	0.4008	WF	0.4634	0.4193
	0.4582	0.4099		0.4687	0.4289
	0.4641	0.4112		0.4750	0.4304
	0.4589	0.4021		0.4695	0.4207
W8	0.4589	0.4021	WG	0.4695	0.4207
	0.4641	0.4112		0.4750	0.4304
	0.4700	0.4126		0.4813	0.4319
	0.4646	0.4034		0.4756	0.4221

d) Chromaticity Region & Coordinates

Region	CIE x	CIE y	Region	CIE x	CIE y
V rank (3000 K)					
V1	0.4147	0.3814	V9	0.4221	0.3984
	0.4183	0.3898		0.4259	0.4073
	0.4242	0.3919		0.4322	0.4096
	0.4203	0.3833		0.4281	0.4006
V2	0.4203	0.3833	VA	0.4281	0.4006
	0.4242	0.3919		0.4322	0.4096
	0.4300	0.3939		0.4385	0.4119
	0.4259	0.3853		0.4342	0.4028
V3	0.4259	0.3853	VB	0.4342	0.4028
	0.4300	0.3939		0.4385	0.4119
	0.4359	0.3960		0.4449	0.4141
	0.4316	0.3873		0.4403	0.4049
V4	0.4316	0.3873	VC	0.4403	0.4049
	0.4359	0.3960		0.4449	0.4141
	0.4418	0.3981		0.4513	0.4164
	0.4373	0.3893		0.4465	0.4071
V5	0.4183	0.3898	VD	0.4259	0.4073
	0.4221	0.3984		0.4299	0.4165
	0.4281	0.4006		0.4364	0.4188
	0.4242	0.3919		0.4322	0.4096
V6	0.4242	0.3919	VE	0.4322	0.4096
	0.4281	0.4006		0.4364	0.4188
	0.4342	0.4028		0.4430	0.4212
	0.4300	0.3939		0.4385	0.4119
V7	0.4300	0.3939	VF	0.4385	0.4119
	0.4342	0.4028		0.4430	0.4212
	0.4403	0.4049		0.4496	0.4236
	0.4359	0.3960		0.4449	0.4141
V8	0.4359	0.3960	VG	0.4449	0.4141
	0.4403	0.4049		0.4496	0.4236
	0.4465	0.4071		0.4562	0.4260
	0.4418	0.3981		0.4513	0.4164

Region	CIE x	CIE y	Region	CIE x	CIE y
U rank (3500 K)					
U1	0.3889	0.3690	U9	0.3941	0.3848
	0.3915	0.3768		0.3968	0.3930
	0.3981	0.3800		0.4040	0.3966
	0.3953	0.3720		0.4010	0.3882
U2	0.3953	0.3720	UA	0.4010	0.3882
	0.3981	0.3800		0.4040	0.3966
	0.4048	0.3832		0.4113	0.4001
	0.4017	0.3751		0.4080	0.3916
U3	0.4017	0.3751	UB	0.4080	0.3916
	0.4048	0.3832		0.4113	0.4001
	0.4116	0.3865		0.4186	0.4037
	0.4082	0.3782		0.4150	0.3950
U4	0.4082	0.3782	UC	0.4150	0.3950
	0.4116	0.3865		0.4186	0.4037
	0.4183	0.3898		0.4259	0.4073
	0.4147	0.3814		0.4221	0.3984
U5	0.3915	0.3768	UD	0.3968	0.3930
	0.3941	0.3848		0.3996	0.4015
	0.4010	0.3882		0.4071	0.4052
	0.3981	0.3800		0.4040	0.3966
U6	0.3981	0.3800	UE	0.4040	0.3966
	0.4010	0.3882		0.4071	0.4052
	0.4080	0.3916		0.4146	0.4089
	0.4048	0.3832		0.4113	0.4001
U7	0.4048	0.3832	UF	0.4113	0.4001
	0.4080	0.3916		0.4146	0.4089
	0.4150	0.3950		0.4222	0.4127
	0.4116	0.3865		0.4186	0.4037
U8	0.4116	0.3865	UG	0.4186	0.4037
	0.4150	0.3950		0.4222	0.4127
	0.4221	0.3984		0.4299	0.4165
	0.4183	0.3898		0.4259	0.4073

d) Chromaticity Region & Coordinates

Region	CIE x	CIE y	Region	CIE x	CIE y
T rank (4000 K)					
T1	0.3670	0.3578	T9	0.3702	0.3722
	0.3726	0.3612		0.3763	0.3760
	0.3744	0.3685		0.3782	0.3837
	0.3686	0.3649		0.3719	0.3797
T2	0.3726	0.3612	TA	0.3763	0.3760
	0.3783	0.3646		0.3825	0.3798
	0.3804	0.3721		0.3847	0.3877
	0.3744	0.3685		0.3782	0.3837
T3	0.3783	0.3646	TB	0.3825	0.3798
	0.3840	0.3681		0.3887	0.3836
	0.3863	0.3758		0.3912	0.3917
	0.3804	0.3721		0.3847	0.3877
T4	0.3840	0.3681	TC	0.3887	0.3837
	0.3898	0.3716		0.3950	0.3875
	0.3924	0.3794		0.3978	0.3958
	0.3863	0.3758		0.3912	0.3917
T5	0.3686	0.3649	TD	0.3719	0.3797
	0.3744	0.3685		0.3782	0.3837
	0.3763	0.3760		0.3802	0.3916
	0.3702	0.3722		0.3736	0.3874
T6	0.3744	0.3685	TE	0.3782	0.3837
	0.3804	0.3721		0.3847	0.3877
	0.3825	0.3798		0.3869	0.3958
	0.3763	0.3760		0.3802	0.3916
T7	0.3804	0.3721	TF	0.3847	0.3877
	0.3863	0.3758		0.3912	0.3917
	0.3887	0.3836		0.3937	0.4001
	0.3825	0.3798		0.3869	0.3958
T8	0.3863	0.3758	TG	0.3912	0.3917
	0.3924	0.3794		0.3978	0.3958
	0.3950	0.3875		0.4006	0.4044
	0.3887	0.3836		0.3937	0.4001

d) Chromaticity Region & Coordinates

Region	CIE x	CIE y	Region	CIE x	CIE y	Region	CIE x	CIE y	Region	CIE x	CIE y	Region	CIE x	CIE y
R rank (5000 K)			QR rank (5300 K)			Q rank (5700 K)			PQ rank (6000 K)			P rank (6500 K)		
R1	0.3371	0.3490	Q2	0.3290	0.3417	Q1	0.3215	0.3350	P2	0.3144	0.3186	P1	0.3068	0.3113
	0.3451	0.3554		0.3371	0.3490		0.3290	0.3417		0.3221	0.3261		0.3144	0.3186
	0.344	0.3427		0.3366	0.3369		0.3290	0.330		0.3213	0.3373		0.3130	0.329
	0.3366	0.3369		0.3290	0.3300		0.3222	0.3243		0.3130	0.3290		0.3048	0.3207
R2	0.3451	0.3554	R1	0.3371	0.3490	Q2	0.3290	0.3417	Q1	0.3215	0.335	P2	0.3144	0.3186
	0.3533	0.3620		0.3451	0.3554		0.3371	0.3490		0.3290	0.3417		0.3221	0.3261
	0.3515	0.3487		0.3440	0.3427		0.3366	0.3369		0.3290	0.3300		0.3213	0.3373
	0.3440	0.3427		0.3366	0.3369		0.3290	0.3300		0.3222	0.3243		0.3130	0.3290
R3	0.3376	0.3616	Q4	0.3290	0.3538	Q3	0.3207	0.3462	P4	0.3130	0.3290	P3	0.3048	0.3207
	0.3463	0.3687		0.3376	0.3616		0.3290	0.3538		0.3213	0.3373		0.3130	0.3290
	0.3451	0.3554		0.3371	0.3490		0.3290	0.3417		0.3205	0.3481		0.3115	0.3391
	0.3371	0.349		0.3290	0.3417		0.3215	0.3350		0.3115	0.3391		0.3028	0.3304
R4	0.3463	0.3687	R3	0.3376	0.3616	Q4	0.3290	0.3538	Q3	0.3207	0.3462	P4	0.3130	0.3290
	0.3551	0.3760		0.3463	0.3687		0.3376	0.3616		0.3290	0.3538		0.3213	0.3373
	0.3533	0.3620		0.3451	0.3554		0.3371	0.3490		0.3290	0.3417		0.3205	0.3481
	0.3451	0.3554		0.3371	0.3490		0.3290	0.3417		0.3215	0.3350		0.3115	0.3391

e) MacAdam Ellipse ($I_f = 350 \text{ mA}$, $T_j = 85 \text{ }^\circ\text{C}$)

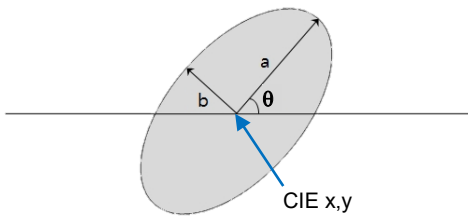

Nom. CCT (K)	Color Rank	Ellipse	Center		Rotation Angle θ ($^\circ$)	a	b
			CIE x	CIE y			
2200	YM	3-step	0.5018	0.4153	53.45	0.0072	0.0040
2700	WM	3-step	0.4578	0.4101	53.70	0.0081	0.0042
3000	VM	3-step	0.4338	0.4030	53.22	0.0083	0.0041
3500	UM	3-step	0.4073	0.3917	54.00	0.0093	0.0041
4000	TM	3-step	0.3818	0.3797	53.72	0.0094	0.0040
5000	RN	5-step	0.3447	0.3553	59.62	0.0137	0.0059
5700	QN	5-step	0.3287	0.3417	59.10	0.0125	0.0053
6500	PN	5-step	0.3123	0.3282	58.57	0.0116	0.0048

Note:

Samsung maintains measurement tolerance of: $C_x, C_y = \pm 0.005$

3. Typical Characteristics Graphs

a) Spectrum Distribution ($I_f = 350 \text{ mA}$, $T_j = 85 \text{ }^\circ\text{C}$)

Cool White (CRI70)

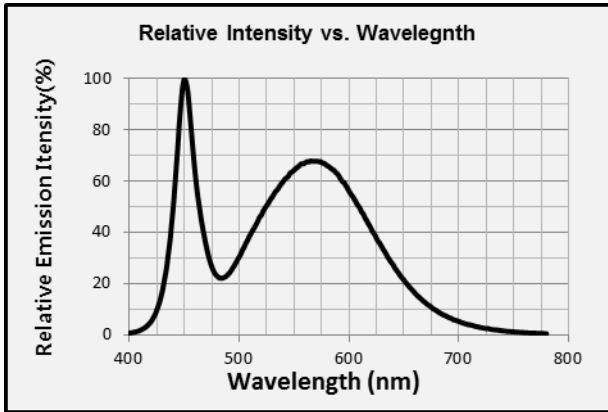

Warm White (CRI80)

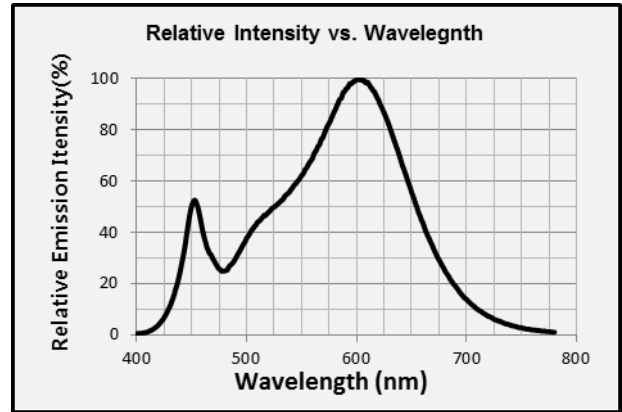

Warm White (CRI90)

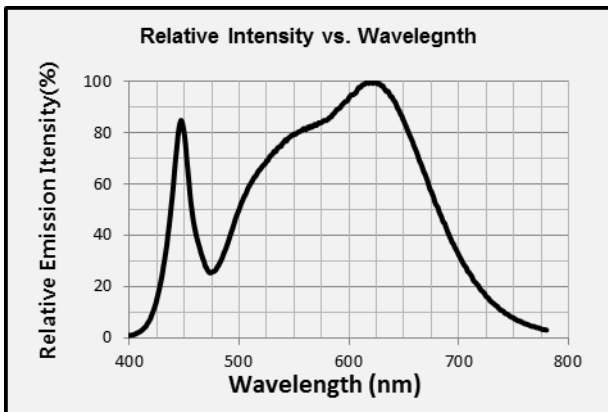

b) Forward Current Characteristics ($T_j = 85 \text{ }^\circ\text{C}$)

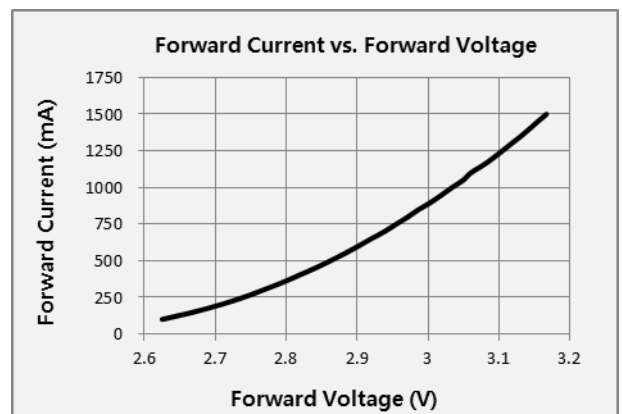
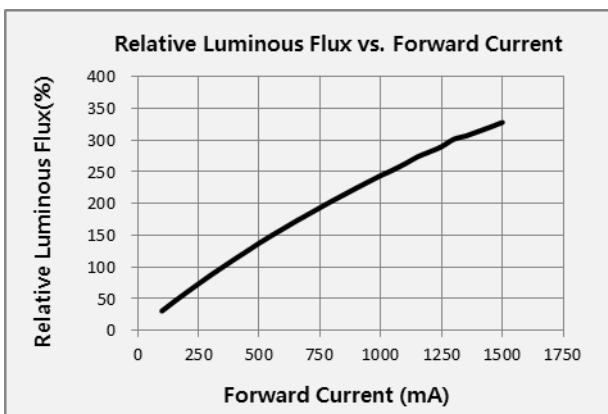

c) Temperature Characteristics ($I_f = 350 \text{ mA}$)

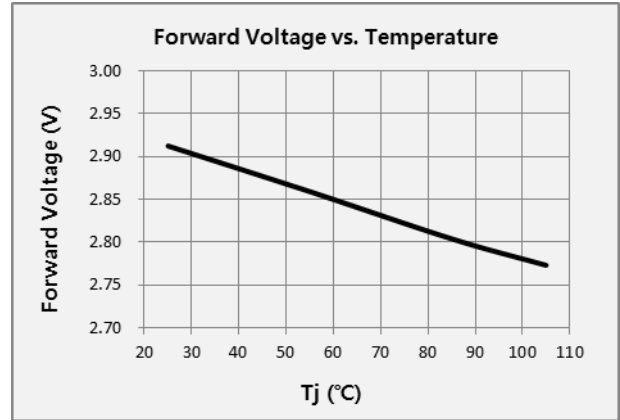
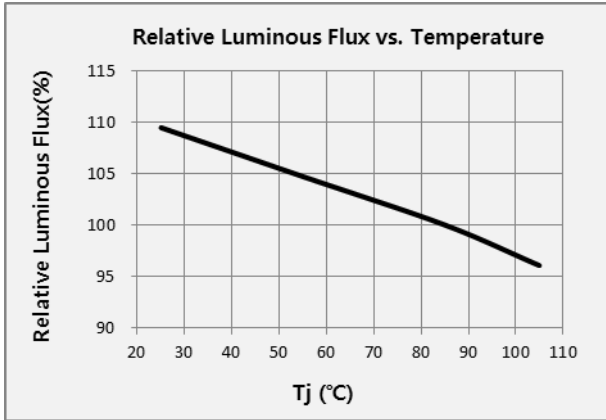

d) Color Shift Characteristics ($I_f = 350 \text{ mA}$, $T_j = 85 \text{ °C}$)

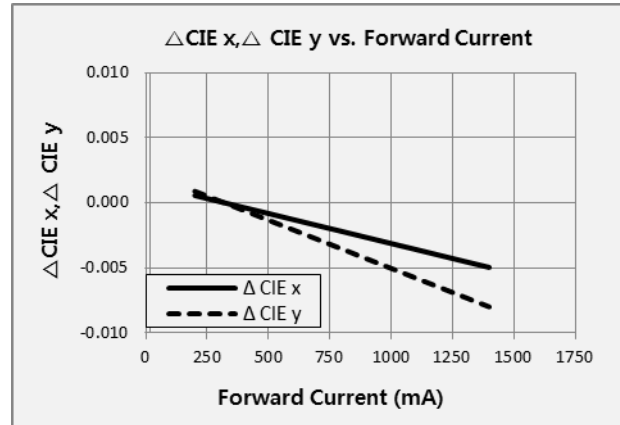
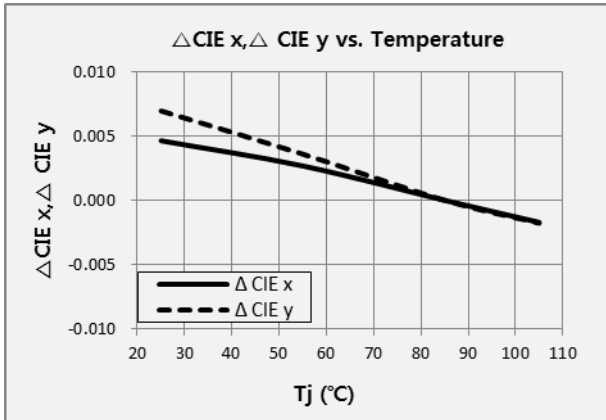

e) Derating Curve and Beam Angle Characteristics ($I_f = 350 \text{ mA}$, $T_j = 25 \text{ °C}$)

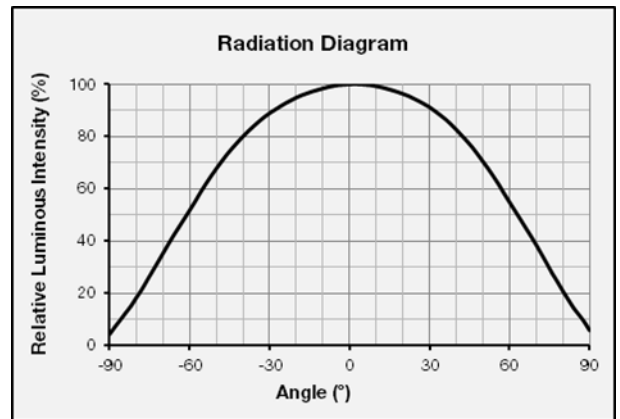
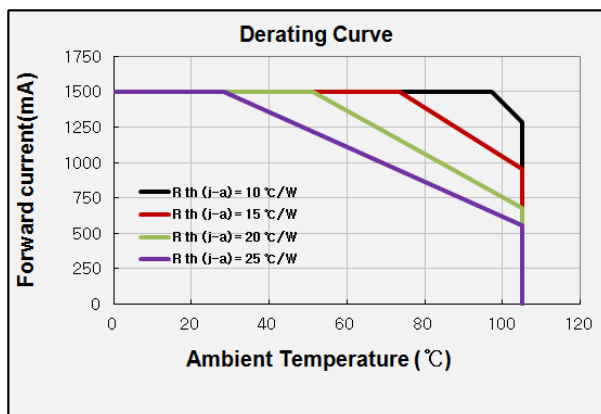

4. Outline Drawing & Dimension

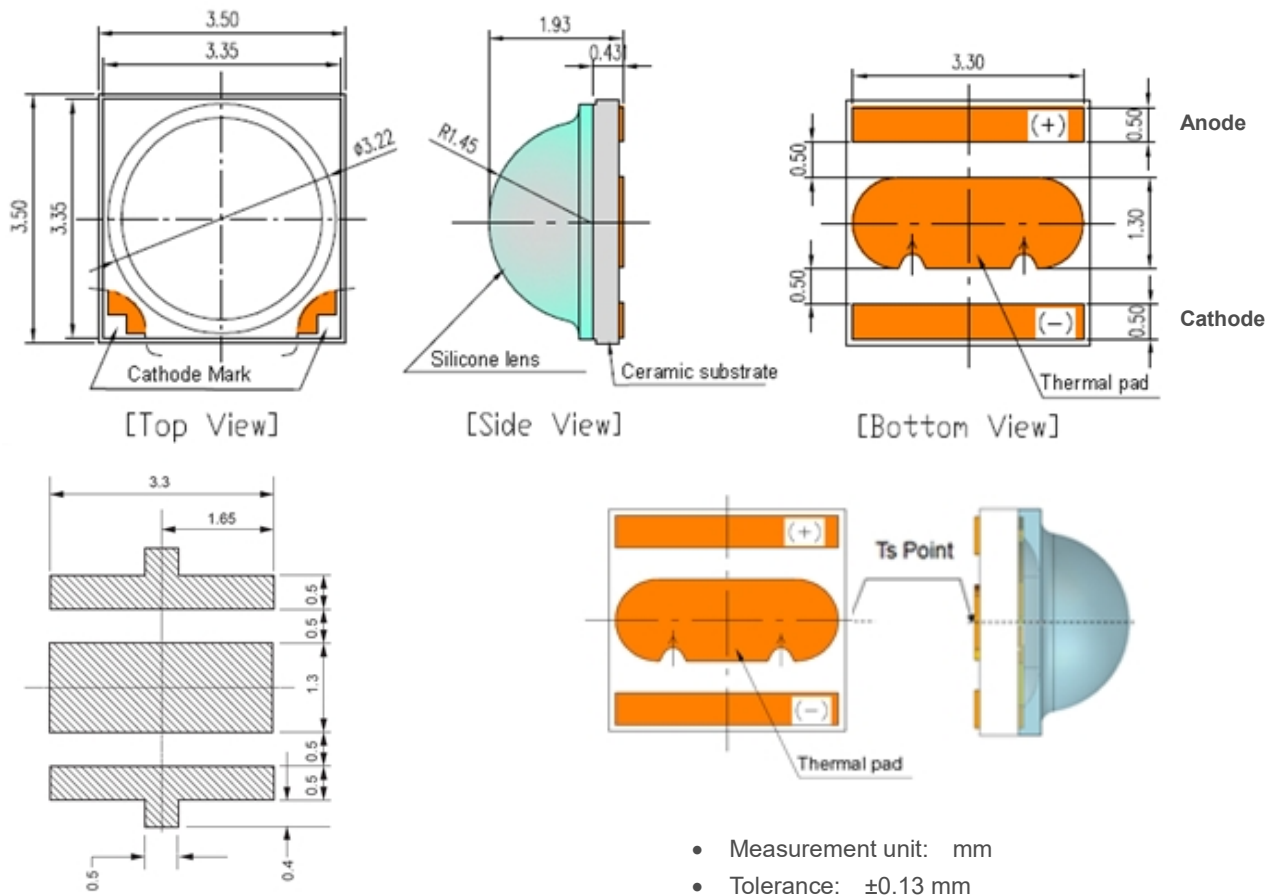

Recommended Soldering Pattern

Notes:

- 1) This LED has built-in ESD protection device(s) connected in parallel to LED chip(s).
- 2) The thermal pad is electrically isolated from the anode and cathode contact pads.
- 3) T_s point and measurement method:
 - ① Measure the nearest point to thermal pad as shown above. If necessary, remove PSR of PCB to reach T_s point.
 - ② All pads must be soldered to the PCB to dissipate heat properly, otherwise the LED can be damaged.

Precautions:

- 1) Pressure on the LEDs will influence to the reliability of the LEDs. Precautions should be taken to avoid strong pressure on the LEDs. Do not put stress on the LEDs during heating.
- 2) Re-soldering should not be done after the LEDs have been soldered. If re-soldering is unavoidable, LED's characteristics should be carefully checked before and after such repair.
- 3) Do not stack assembled PCBs together. Since materials of LEDs is soft, abrasion between two PCB assembled with LED might cause catastrophic failure of the LEDs.

5. Reliability Test Items & Conditions

a) Test Items

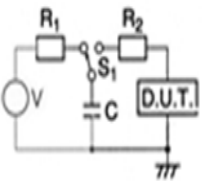
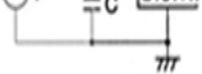
Test Item	Test Condition	Test Hour / Cycle
Room Temperature Life Test	25 °C, , Maximum Rated Drive Current	1000 h
High Temperature Life Test	85 °C, , Maximum Rated Drive Current	1000 h
High Temperature Humidity Life Test	85 °C, 85 % RH, , Maximum Rated Drive Current	1000 h
Low Temperature Life Test	-40 °C, , Maximum Rated Drive Current	1000 h
Damp Heat Cycling	-10 °C ↔ 25 °C 95 % RH ↔ 65 °C 95 % RH , Maximum Rated Drive Current, 24 h / 1 cycle	10 cycles
Powered Temperature Cycle	-40 °C / 85 °C each 20 min, 100 min transfer power on/off each 5 min, , Maximum Rated Drive Current	100 cycles
Temperature Cycling	-45 °C / 15 min ↔ 125 °C / 15 min temperature change within 5 min	500 cycles
High Temperature Storage	120 °C	1000 h
Low Temperature Storage	-40 °C	1000 h
ESD (HBM)		R ₁ : 10 MΩ R ₂ : 1.5 kΩ C: 100 pF V: ±8 kV 5 times
ESD (MM)		R ₁ : 10 MΩ R ₂ : 0 C: 200 pF V: ±0.5 kV 5 times
Vibration Test	20~2000~20 Hz, 200 m/s ² , sweep 4 min X, Y, Z 3 direction, each 1 cycle	4 cycles
Mechanical Shock Test	1500 g, 0.5 ms 3 shocks each X-Y-Z axis	5 cycles

b) Criteria for Judging the Damage

Item	Symbol	Test Condition (T _j = 25 °C)	Limit	
			Min.	Max.
Forward Voltage	V _F	I _F = 350 mA	Init. Value * 0.9	Init. Value * 1.1
Luminous Flux	Φ _v	I _F = 350 mA	Init. Value * 0.7	Init. Value * 1.1

6. Soldering Conditions

a) Reflow Conditions (Pb free)

Reflow frequency: 2 times max.

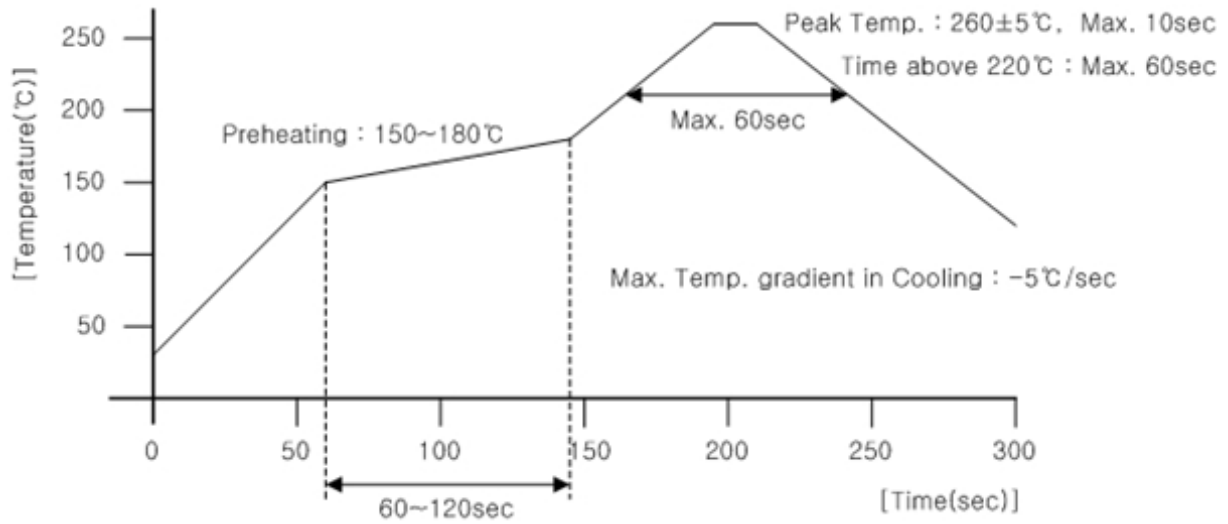

b) Manual Soldering Conditions

Not more than 5 seconds @ max. 300 °C, under soldering iron.

7. Tape & Reel

a) Taping Dimension

(unit: mm)

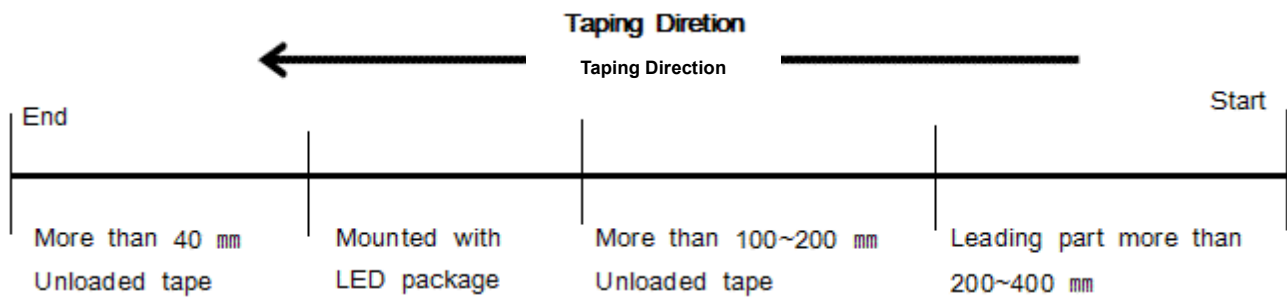
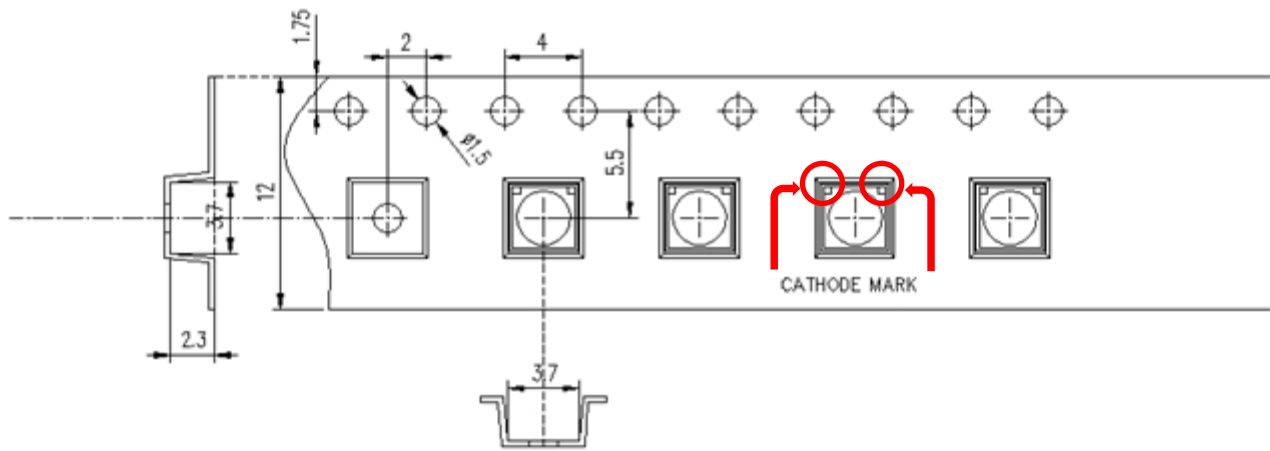

b) Reel Dimension

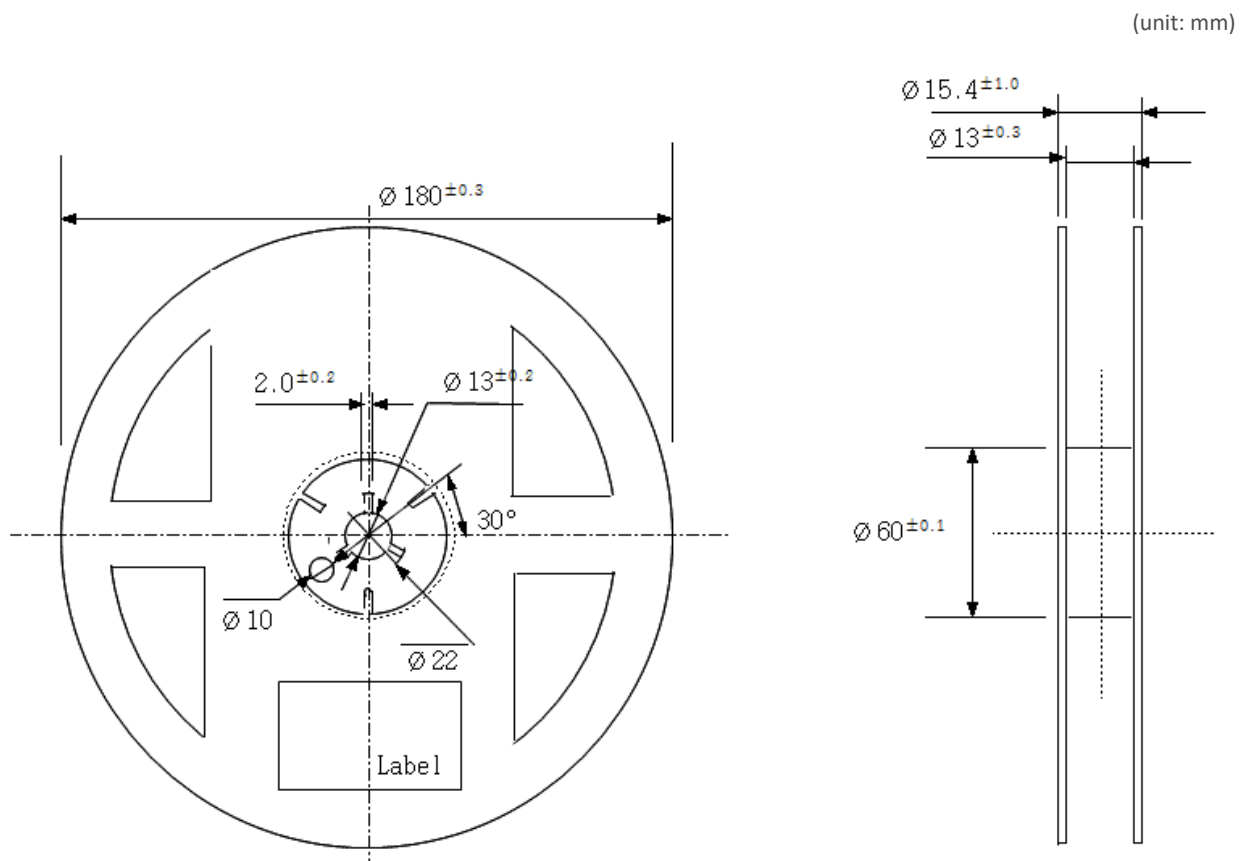
**Notes:**

- 1) Quantity: The quantity/reel is 1,000 pcs
- 2) Cumulative tolerance: Cumulative tolerance / 10 pitches is ± 0.2 mm
- 3) Adhesion strength of cover tape: Adhesion strength is 0.1-0.7 N when the cover tape is turned off from the carrier tape at 10° angle to the carrier tape
- 4) Packaging: P/N, Manufacturing data code no. and quantity are indicated on the aluminum packing bag

8. Label Structure

a) Label Structure

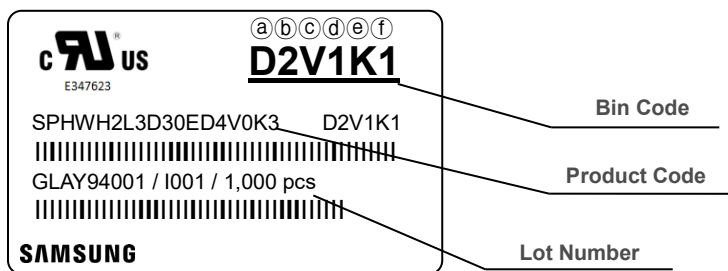

Note: Denoted bin code and product code above is only an example (see description on page 7)

Bin Code:

ⒶⒷ: Forward Voltage bin (refer to page 15)

ⒸⒹ: Chromaticity bin (refer to page 16-19)

ⒺⒻ: Luminous Flux bin (refer to page 8-11)

b) Lot Number

The lot number is composed of the following characters:

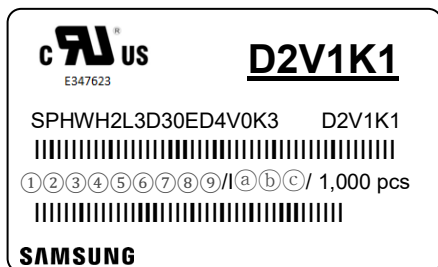

①②③④⑤⑥⑦⑧⑨ / IⒶⒷⒸ / 1,000 pcs

①, ② : Production site (GL: Tianjin, China, GB : Nanchang, China)

③ : Product state (A: Normal, B: Bulk, C: First Production, R: Reproduction, S: Sample)

④ : Year (Y: 2014, Z: 2015, A: 2016, B: 2017, C: 2018, D: 2019 ...)

⑤ : Month (1~9, A, B, C)

⑥ : Day (1~9, A, B~V)

⑦⑧⑨ : Product serial number (001 ~ 999)

ⒶⒷⒸ : Reel number (001 ~ 999)

b) Aluminum Vinyl Packing Bag



CAUTION
 This bag contains
MOISTURE SENSITIVE DEVICES

LEVEL
2a

1. Shelf life in sealed bag: 12 months at <math>< 40^{\circ}\text{C}</math> and <math>< 90\%</math> relative humidity (RH)
2. Peak package body temperature: 240 °C
3. After this bag is opened, devices that will be subjected to reflow solder or other high temperature processes must be:
 - a. Mounted within 672 hours at factory conditions of equal to or less than 30°C / 60% RH, or
 - b. Stored at <math>< 10\%</math> RH
4. Devices require bake, before mounting, if:
 - a. Humidity Indicator Card is > 65% when read at 23±5°C, or
 - b. 2a is not met.
5. If baking is required, devices must be baked for 1 hours at 60±5°C

Note: If device containers cannot be subjected to high temperature or shorter bake times are desired, reference IPC/JEDEC J-STD-033 for bake procedure.

Bag seal due date: _____
 (If blank, see code label)

Note: Level and body temperature by IPC/JEDEC J-STD-020



D2V1K1

SPHWH2L3D30ED4V0K3 D2V1K1
 |||
 GLAY94001 / I001 / 1,000 pcs
 |||

SAMSUNG







ATTENTION
 OBSERVE PRECAUTIONS
 FOR HANDLING
 ELECTROSTATIC
 SENSITIVE
 DEVICES



주의 사항

이 알루미늄 지퍼 팩은 습기 및 정전기로부터 제품을 보호하기 위하여 제작되었습니다. 개봉 후에는 즉시 솔더 작업을 실시하는 것을 권장합니다.

습기 및 정전기로부터 제품을 보호 하기 위해서 개봉 후 사용하지 않는 자재는 본 팩에 넣어 보관 하시기 바랍니다. 사용하지 않는 자재를 본 팩에 넣을 때는 반드시 동봉된 드라이 팩과 함께 넣고 지퍼부분을 완전하게 밀봉하여 주시기 바랍니다.

Important

This Al Zipper bag is designed to protect the enclosed products from moisture and ESD. Once opened, the products should be soldered onto the printed circuit board immediately. When not in use, please do not leave the products unprotected by the Al Zipper Bag. To repack unused products., please ensure the zip-lock is completely sealed with the dry pack left inside.

c) Silica Gel & Humidity Indicator Card inside Aluminum Vinyl Bag



DESICCANT
SILICA
 DO NOT
 EAT
 DE
 SIL

HUMISAFE™

**HUMIDITY INDICATOR
 COBALT-FREE**

10%

20%

30%

40%

50%

60%







READ AT TOP OF GREEN COLOR
 CHANGE BETWEEN YELLOW AND GREEN

Warning If Green
 Change Desiccant

GP&E Co., Ltd.
 6CF-60NS

10. Precautions in Handling & Use

- 1) For over-current protection, users are recommended to apply resistors connected in series with the LEDs to mitigate sudden change of the forward current caused by shift of forward voltage.
- 2) This device should not be used in any type of fluid such as water, oil, organic solvent, etc. When cleaning is required, IPA is recommended as the cleaning agent. Some solvent-based cleaning agent may damage the silicone resins used in the device.
- 3) When the device is in operation, the forward current should be carefully determined considering the maximum ambient temperature and corresponding junction temperature.
- 4) LEDs must be stored in a clean environment. If the LEDs are to be stored for three months or more after being shipped from Samsung, they should be packed with a nitrogen-filled container (shelf life of sealed bags is 12 months at temperature 0~40 °C, 0~90 % RH).
- 5) After storage bag is opened, device subjected to soldering, solder reflow, or other high temperature processes must be:
 - a. Mounted within 672 hours (28 days) at an assembly line with a condition of no more than 30 °C / 60 % RH, or
 - b. Stored at <10 % RH
- 6) Repack unused devices with anti-moisture packing, fold to close any opening and then store in a dry place.
- 7) Devices require baking before mounting, if humidity card reading is >60 % at 23 ± 5 °C.
- 8) Devices must be baked for 1 hour at 60 ± 5 °C, if baking is required.
- 9) The LEDs are sensitive to the static electricity and surge current. It is recommended to use a wrist band or anti-electrostatic glove when handling the LEDs. If voltage exceeding the absolute maximum rating is applied to LEDs, it may cause damage or even destruction to LED devices. Damaged LEDs may show some unusual characteristics such as increase in leakage current, lowered turn-on voltage, or abnormal lighting of LEDs at low current.
- 10) VOCs (Volatile Organic Compounds) can be generated from adhesives, flux, hardener or organic additives used in luminaires (fixtures). Transparent LED silicone encapsulant is permeable to those chemicals and they may lead to a discoloration of encapsulant when they exposed to heat or light. This phenomenon can cause a significant loss of light emitted (output) from the luminaires. In order to prevent these problems, we recommend users to know the physical properties of materials used in luminaires and they must be carefully selected.

Legal and additional information.

[About Samsung Electronics Co., Ltd.](#)

Samsung Electronics Co., Ltd. inspires the world and shapes the future with transformative ideas and technologies, redefining the worlds of TVs, smartphones, wearable devices, tablets, cameras, digital appliances, printers, medical equipment, network systems and semiconductors.

We are also leading in the Internet of Things space through, among others, our Digital Health and Smart Home initiatives. We employ 307,000 people across 84 countries. To discover more, please visit our official website at www.samsung.com and our official blog at global.samsungtomorrow.com.

Copyright © 2016 Samsung Electronics Co., Ltd. All rights reserved.

Samsung is a registered trademark of Samsung Electronics Co., Ltd.

Specifications and designs are subject to change without notice. Non-metric weights and measurements are approximate. All data were deemed correct at time of creation. Samsung is not liable for errors or omissions. All brand, product, service names and logos are trademarks and/or registered trademarks of their respective owners and are hereby recognized and acknowledged.

Samsung Electronics Co., Ltd.

1, Samsung ro

Giheung-gu

Yongin-si, Gyeonggi-do, 17113

KOREA

www.samsungled.com

The Samsung logo, consisting of the word "SAMSUNG" in a bold, blue, sans-serif font.