

DDR3 SDRAM Memory

Product Guide

SAMSUNG ELECTRONICS RESERVES THE RIGHT TO CHANGE PRODUCTS, INFORMATION AND SPECIFICATIONS WITHOUT NOTICE.

Products and specifications discussed herein are for reference purposes only. All information discussed herein is provided on an "AS IS" basis, without warranties of any kind.

This document and all information discussed herein remain the sole and exclusive property of Samsung Electronics. No license of any patent, copyright, mask work, trademark or any other intellectual property right is granted by one party to the other party under this document, by implication, estoppel or otherwise.

Samsung products are not intended for use in life support, critical care, medical, safety equipment, or similar applications where product failure could result in loss of life or personal or physical harm, or any military or defense application, or any governmental procurement to which special terms or provisions may apply.

For updates or additional information about Samsung products, contact your nearest Samsung office.

All brand names, trademarks and registered trademarks belong to their respective owners.

© 2012 Samsung Electronics Co., Ltd. All rights reserved.

2. DDR3 SDRAM Component Product Guide

Density	Banks	Part Number	Package & Power, Temp. & Speed	Org.	VDD Voltage ¹	PKG	Avail.	NOTE
1Gb G-die	8Banks	K4B1G0446G	BCF8/H9/K0/MA	256M x 4	1.5V	78 ball FBGA	Now	
		K4B1G0846G	BCF8/H9/K0/MA	128M x 8				
		K4B1G0446G	BYF8/H9/K0	256M x 4	1.35V			
		K4B1G0846G	BYF8/H9/K0	128M x 8				
2Gb C-die	8Banks	K4B2G0446C	HCF8/H9/K0	512M x 4	1.5V	78 ball FBGA	Now	
		K4B2G0846C	HCF8/H9/K0	256M x 8				
		K4B2G0446C	HYF8/H9	512M x 4	1.35V			
		K4B2G0846C	HYF8/H9	256M x 8				
2Gb D-die	8Banks	K4B2G0446D	HCF8/H9/K0/MA	512M x 4	1.5V	78 ball FBGA	Now	
		K4B2G0846D	HCF8/H9/K0/MA	256M x 8				
		K4B2G0446D	HYF8/H9/K0	512M x 4	1.35V			
		K4B2G0846D	HYF8/H9/K0	256M x 8				
2Gb E-die	8Banks	K4B2G0446E	BCH9/K0/MA	512M x 4	1.5V	78 ball FBGA	Now	
		K4B2G0846E	BCH9/K0/MA	256M x 8				
		K4B2G0446E	BYH9/K0	512M x 4	1.35V			
		K4B2G0846E	BYH9/K0	256M x 8				
4Gb B-die	8Banks	K4B4G0446B	HCF8/H9/K0/MA	1G x 4	1.5V	78 ball FBGA	Now	
		K4B4G0846B	HCF8/H9/K0/MA	512M x 8				
		K4B4G1646B	HCH9/K0	256M x 16				
		K4B4G0446B	HYF8/H9/K0	1G x 4	1.35V			
		K4B4G0846B	HYF8/H9/K0	512M x 8				
		K4B4G1646B	HYH9/K0	256M x 16				
4Gb C-die	8Banks	K4B4G0446C	BCH9/K0/MA	1G x 4	1.5V	78 ball FBGA	Now	
		K4B4G0846C	BCH9/K0/MA	512M x 8				
		K4B4G0446C	BYH9/K0	1G x 4	1.35V			
		K4B4G0846C	BYH9/K0	512M x 8				
4Gb D-die	8Banks	K4B4G0446D	BCH9/K0/MA	1G x 4	1.5V	78 ball FBGA	1Q'13	
		K4B4G0846D	BCH9/K0/MA	512M x 8				
		K4B4G0446D	BYH9/K0	1G x 4	1.35V			
		K4B4G0846D	BYH9/K0	512M x 8				
8G B-die	8Banks	K4B8G1646B	MCK0	DDP 512M x 16	1.5V	96 ball FBGA	Now	
		K4B8G1646B	MYH9/K0	DDP 512M x 16	1.35V			
		K4B8G3346B	MCH9/K0	DDP 256M x 32	1.5V	136 ball FBGA	Now	
		K4B8G3346B	MYH9/K0	DDP 256M x 32	1.35V			
16G B-die	8Banks	K4BAG0446B	ECH9/K0	QDP 4G x 4	1.5V	78 ball FBGA	Now	
		K4BAG0446B	EYH9/K0	QDP 4G x 4	1.35V			
		K4BAG0446B	OCK0	QDP 4G x 4	1.5V	78 ball FBGA	Now	
		K4BAG0446B	OYF8/H9/K0	QDP 4G x 4	1.35V			

* NOTE

1. 1.35V product is 1.5V operatable.

4. DDR3 SDRAM Module Product Guide

4.1 240Pin DDR3 Unbuffered DIMM (1.5V Product)

240Pin DDR3 Unbuffered DIMM															
Org.	Density	Part Number	Speed	Raw Card	Composition	Comp. Version		Internal Banks	Rank	PKG	Height	Avail.	NOTE		
128Mx 72	1GB	M391B2873GB0	CF8/H9/K0/MA	D(1Rx8)	128M x 8 * 9 pcs	1Gb	G-die	8	1	78 ball FBGA	30mm	Now			
256Mx 64	2GB	M378B5773CH0	CF8/H9/K0	A(1Rx8)	256M x 8 * 8 pcs	2Gb	C-die	8	1	78 ball FBGA	30mm	Now			
		M378B5773DH0	CF8/H9/K0/MA		256M x 8 * 8 pcs	2Gb	D-die					Now			
		M378B5773EB0	CH9/K0/MA		256M x 8 * 8 pcs	2Gb	E-die					Now			
256Mx 72	2GB	M391B5673GB0	CF8/H9/K0/MA	E(2Rx8)	128M x 8 * 18 pcs	1Gb	G-die	8	2	78 ball FBGA	30mm	Now			
		M391B5773CH0	CF8/H9/K0	D(1Rx8)	256M x 8 * 9 pcs	2Gb	C-die					8	1	Now	
		M391B5773DH0	CF8/H9/K0/MA		256M x 8 * 9 pcs	2Gb	D-die							Now	
		M391B5773EB0	CH9/K0/MA		256M x 8 * 9 pcs	2Gb	E-die							Now	
512Mx 64	4GB	M378B5273CH0	CF8/H9/K0	B(2Rx8)	256M x 8 * 16 pcs	2Gb	C-die	8	2	78 ball FBGA	30mm	Now			
		M378B5273DH0	CF8/H9/K0		256M x 8 * 16 pcs	2Gb	D-die					Now			
		M378B5273EB0	CH9/K0/MA		256M x 8 * 16 pcs	2Gb	E-die					Now			
		M378B5173CB0	CK0	D(1Rx8)	512M x 8 * 8 pcs	4Gb	C-die	8	1	Now					
		M378B5173DB0	CK0/MA	512M x 8 * 8 pcs	4Gb	D-die	1Q'13								
512Mx 72	4GB	M391B5273CH0	CF8/H9/K0	E(2Rx8)	256M x 8 * 18 pcs	2Gb	C-die	8	2	78 ball FBGA	30mm	Now			
		M391B5273DH0	CF8/H9/K0/MA		256M x 8 * 18 pcs	2Gb	D-die					Now			
		M391B5273EB0	CH9/K0/MA		256M x 8 * 18 pcs	2Gb	E-die					Now			
1Gx 64	8GB	M378B1G73BH0	CF8/H9/K0	B(2Rx8)	512M x 8 * 16 pcs	4Gb	B-die	8	2	78 ball FBGA	30mm	Now			
		M378B1G73CB0	CK0		512M x 8 * 16 pcs	4Gb	C-die					Now			
		M378B5173DB0	CK0/MA		1G x 8 * 8 pcs	4Gb	D-die					1Q'13			
1Gx 72	8GB	M391B1G73BH0	CF8/H9/K0/MA	E(2Rx8)	512M x 8 * 18 pcs	4Gb	B-die	8	2	78 ball FBGA	30mm	Now			

4.2 240Pin DDR3 Unbuffered DIMM (1.35V Product)

240Pin DDR3 Unbuffered DIMM															
Org.	Density	Part Number	Speed	Raw Card	Composition	Comp. Version		Internal Banks	Rank	PKG	Height	Avail.	NOTE		
128Mx 72	1GB	M391B2873GB0	YF8/H9/K0	D(1Rx8)	128M x 8 * 9 pcs	1Gb	G-die	8	1	78 ball FBGA	30mm	Now			
256Mx 72	2GB	M391B5673GB0	YF8/H9/K0	E(2Rx8)	128M x 8 * 18 pcs	1Gb	G-die	8	2	78 ball FBGA	30mm	Now			
		M391B5773CH0	YF8/H9	D(1Rx8)	256M x 8 * 9 pcs	2Gb	C-die					8	1	Now	
		M391B5773DH0	YF8/H9/K0		256M x 8 * 9 pcs	2Gb	D-die							Now	
512Mx 72	4GB	M391B5273CH0	YF8/H9	E(2Rx8)	256M x 8 * 18 pcs	2Gb	C-die	8	2	78 ball FBGA	30mm	Now			
		M391B5273DH0	YF8/H9/K0		256M x 8 * 18 pcs	2Gb	D-die					Now			
1Gx 72	8GB	M391B1G73BH0	YF8/H9/K0	E(2Rx8)	512M x 8 * 18 pcs	4Gb	B-die	8	2	78 ball FBGA	30mm	Now			

* NOTE : 1.35V product is 1.5V operatable.

4.3 240Pin DDR3 VLP Unbuffered DIMM (1.35V Product)

240Pin DDR3 VLP Unbuffered DIMM													
Org.	Density	Part Number	Speed	Raw Card	Composition	Comp. Version		Internal Banks	Rank	PKG	Height	Avail.	NOTE
256Mx 72	2GB	M390B5773DH0	YH9	J(1Rx8)	256M x 8 * 9pcs	2Gb	D-die	8	1	78 ball FBGA	18.75mm	Now	
512Mx 72	4GB	M390B5273DH0	YH9	K(2Rx8)	256M x 8 * 18 pcs	2Gb	D-die	8	2	78 ball FBGA	18.75mm	Now	
		M390B5173BH0	YH9	J(1Rx8)	256M x 8 * 18 pcs	4Gb	B-die	8	1			Now	
1Gx 72	8GB	M390B1G73BH0	YH9	K(2Rx8)	512M x 8 * 18 pcs	4Gb	B-die	8	2	78 ball FBGA	18.75mm	Now	

* NOTE : 1.35V product is 1.5V operatable.

4.4 204Pin DDR3 SoDIMM (1.5V Product)

204Pin DDR3 SODIMM													
Org.	Density	Part Number	Speed	Raw Card	Composition	Comp. Version		Internal Banks	Rank	PKG	Height	Avail.	NOTE
256Mx 64	2GB	M471B5773CHS	CF8/H9/K0	B(1Rx8)	256M x 8 * 8 pcs	2Gb	C-die	8	1	78 ball FBGA	30mm	Now	
		M471B5773DH0	CF8/H9/K0		256M x 8 * 8 pcs	2Gb	D-die					Now	
512Mx 64	4GB	M471B5273CH0	CF8/H9/K0	F(2Rx8)	256M x 8 * 16 pcs	2Gb	C-die	8	2	78 ball FBGA	30mm	Now	
		M471B5273DH0	CF8/H9/K0		256M x 8 * 16 pcs	2Gb	D-die					Now	
		M471B5273EB0	CH9/K0		256M x 8 * 16 pcs	2Gb	E-die					Now	
	B(1Rx8)	M471B5173CB0	CK0	512M x 8 * 8 pcs	4Gb	C-die	8	1	Now				
		M471B5173DB0	CH9/K0	512M x 8 * 8 pcs	4Gb	D-die			1Q'13				
1Gx 64	8GB	M471B1G73BH0	CH9/K0	F(2Rx8)	512M x 8 * 16 pcs	4Gb	B-die	8	2	78 ball FBGA	30mm	Now	
		M471B1G73CB0	CK0		512M x 8 * 16 pcs	4Gb	C-die					Now	
		M471B1G73DB0	CH9/K0		512M x 8 * 16 pcs	4Gb	D-die					1Q'13	

4.5 204Pin DDR3 SoDIMM (1.35V Product)

204Pin DDR3 SODIMM													
Org.	Density	Part Number	Speed	Raw Card	Composition	Comp. Version		Internal Banks	Rank	PKG	Height	Avail.	NOTE
256Mx 64	2GB	M471B5773CHS	YF8/H9	B(1Rx8)	256M x 8 * 8 pcs	2Gb	C-die	8	1	78 ball FBGA	30mm	Now	
		M471B5773DH0	YF8/H9/K0		256M x 8 * 8 pcs	2Gb	D-die					Now	
512Mx 64	4GB	M471B5273CH0	YF8/H9	F(2Rx8)	256M x 8 * 16 pcs	2Gb	C-die	8	2	78 ball FBGA	30mm	Now	
		M471B5273DH0	YF8/H9/K0		256M x 8 * 16 pcs	2Gb	D-die					Now	
		M471B5273EB0	YK0		256M x 8 * 16 pcs	2Gb	E-die					Now	
	B(1Rx8)	M471B5173CB0	YH9/K0	512M x 8 * 8 pcs	4Gb	C-die	8	1	Now				
		M471B5173DB0	YH9/K0	512M x 8 * 8 pcs	4Gb	D-die			4Q'12				
1Gx 64	8GB	M471B1G73BH0	YF8/H9/K0	F(2Rx8)	512M x 8 * 16 pcs	4Gb	B-die	8	2	78 ball FBGA	30mm	Now	
		M471B1G73CB0	YH9/K0		512M x 8 * 16 pcs	4Gb	C-die					Now	
		M471B1G73DB0	YH9/K0		512M x 8 * 16 pcs	4Gb	D-die					4Q'12	

* NOTE : 1.35V product is 1.5V operatable.

4.6 204Pin DDR3 ECC SoDIMM (1.35V Product)

204Pin DDR3 SODIMM													
Org.	Density	Part Number	Speed	Raw Card	Composition	Comp. Version		Internal Banks	Rank	PKG	Height	Avail.	NOTE
256Mx 72	2GB	M474B5773DH0	YF8/H9	C(1Rx8)	256M x 8 * 9 pcs	2Gb	D-die	8	1	78 ball FBGA	30mm	Now	
512Mx 72	4GB	M474B5273DH0	YF8/H9	D(2Rx8)	256M x 8 * 18 pcs	2Gb	D-die	8	2	78 ball FBGA	30mm	Now	
		M474B5173BH0	YF8/H9/K0	C(1Rx8)	256M x 8 * 18 pcs	2Gb	B-die	8	1	78 ball FBGA	30mm	Now	
1Gx 72	8GB	M474B1G73BH0	YF8/H9/K0	D(2Rx8)	512M x 8 * 18 pcs	4Gb	B-die	8	2	78 ball FBGA	30mm	Now	

NOTE : 1.35V product is 1.5V operatable.

4.7 240Pin DDR3 Registered DIMM (1.5V Product)

240Pin DDR3 Registered DIMM													
Org.	Density	Part Number	Speed	Raw Card	Composition	Comp. Version		Internal Banks	Rank	PKG	Height	Avail.	NOTE
128Mx 72	1GB	M393B2873GB0	CH9/K0/MA	A(1Rx8)	128M x 8 * 9 pcs	1Gb	G-die	8	1	78 ball FBGA	30mm	Now	
256Mx 72	2GB	M393B5673GB0	CH9/K0/MA	B(2Rx8)	128M x 8 * 18 pcs	1Gb	G-die	8	2	78 ball FBGA	30mm	Now	
		M393B5670GB0	CH9/K0/MA	C(1Rx4)	256M x 4 * 18 pcs	1Gb	G-die	8	1			Now	
		M393B5773CH0	CF8/H9/K0	A(1Rx8)	256M x 8 * 9 pcs	2Gb	C-die	8	1			Now	
		M393B5773DH0	CH9/K0/MA		256M x 8 * 9 pcs	2Gb	D-die					Now	
512Mx 72	4GB	M393B5173GB0	CH9	H(4Rx8)	128M x 8 * 36 pcs	1Gb	G-die	8	4	78 ball FBGA	30mm	Now	
		M393B5170GB0	CH9/K0/MA	E(2Rx4)	256M x 4 * 36 pcs	1Gb	G-die	8	2			Now	
		M393B5273CH0	CF8/H9/K0	B(2Rx8)	256M x 8 * 18 pcs	2Gb	C-die	8	2			Now	
		M393B5273DH0	CH9/K0/MA		256M x 8 * 18 pcs	2Gb	D-die					Now	
		M393B5273EB0	CMA	C(1Rx4)	256M x 8 * 18 pcs	2Gb	E-die	8	1			Now	
		M393B5270CH0	CH9/K0		512M x 4 * 18 pcs	2Gb	C-die					Now	
		M393B5270DH0	CH9/K0/MA	512M x 4 * 18 pcs	2Gb	D-die	Now						
		M393B5270EB0	CH9/MA	512M x 4 * 18 pcs	2Gb	E-die	Now						
1Gx 72	8GB	M393B1K73CH0	CF8/H9	H(4Rx8)	256M x 8 * 36 pcs	2Gb	C-die	8	4	78 ball FBGA	30mm	Now	
		M393B1K73DH0	CH9		256M x 8 * 36 pcs	2Gb	D-die					Now	
		M393B1K73EB0	CH9		256M x 8 * 36 pcs	2Gb	E-die					Now	
		M393B1K70CH0	CF8/H9/K0	E(2Rx4)	512M x 4 * 36 pcs	2Gb	C-die	8	2			Now	
		M393B1K70DH0	CH9/K0/MA		512M x 4 * 36 pcs	2Gb	D-die					Now	
		M393B1K70EB0	CH9/MA	512M x 4 * 36 pcs	2Gb	E-die	Now						
		M393B1G73BH0	CH9/K0/MA	B(2Rx8)	512M x 8 * 18 pcs	4Gb	B-die	8	1			Now	
		M393B1G70BH0	CH9/K0/MA	C(1Rx4)	1G x 4 * 18 pcs	4Gb	B-die					Now	
2Gx 72	16GB	M393B2K70DM0	CF8/H9	AB(4Rx4)	1G DDP x 4 * 36 pcs	2Gb	D-die	8	4	78 ball FBGA	30mm	Now	
		M393B2G70BH0	CF8/H9	E(2Rx4)	1G x 4 * 36 pcs	4Gb	B-die	8	2			Now	
		M393B2G70CB0	CK0/MA		1G x 4 * 36 pcs	4Gb	C-die					Now	
		M393B2G73BH0	CF8/H9	H(4Rx8)	512M x 8 * 36 pcs	4Gb	B-die	8	4			Now	
		M393B2G70DB0	CK0/MA	E(2Rx4)	1G x 4 * 36 pcs	4Gb	D-die	8	2			1Q'13	

4.8 240Pin DDR3 Registered DIMM (1.35V Product)

240Pin DDR3 Registered DIMM													
Org.	Density	Part Number	Speed	Raw Card	Composition	Comp. Version		Internal Banks	Rank	PKG	Height	Avail.	NOTE
128Mx 72	1GB	M393B2873GB0	YF8/H9/K0	A(1Rx8)	128M x 8 * 9 pcs	1Gb	G-die	8	1	78 ball FBGA	30mm	Now	
256Mx 72	2GB	M393B5673GB0	YF8/H9/K0	B(2Rx8)	128M x 8 * 18 pcs	1Gb	G-die	8	2	78 ball FBGA	30mm	Now	
		M393B5670GB0	YF8/H9/K0	C(1Rx4)	256M x 4 * 18 pcs	1Gb	G-die	8	1			Now	
		M393B5773CH0	YF8/H9	A(1Rx8)	256M x 8 * 9 pcs	2Gb	C-die	8	1			Now	
		M393B5773DH0	YF8/H9/K0		256M x 8 * 9 pcs	2Gb	D-die					Now	
512Mx 72	4GB	M393B5173GB0	YF8/H9	H(4Rx8)	128M x 8 * 36 pcs	1Gb	G-die	8	4	78 ball FBGA	30mm	Now	
		M393B5170GB0	YF8/H9/K0	E(2Rx4)	256M x 4 * 36 pcs	1Gb	G-die	8	2			Now	
		M393B5273CH0	YF8/H9	B(2Rx8)	256M x 8 * 18 pcs	2Gb	C-die	8	2			Now	
		M393B5273DH0	YF8/H9/K0		256M x 8 * 18 pcs	2Gb	D-die					Now	
		M393B5273EB0	YH9/K0		256M x 8 * 18 pcs	2Gb	E-die					Now	
		M393B5270CH0	YF8/H9	C(1Rx4)	512M x 4 * 18 pcs	2Gb	C-die	8	1			Now	
		M393B5270DH0	YF8/H9/K0		512M x 4 * 18 pcs	2Gb	D-die					Now	
		M393B5270EB0	YH9/K0		512M x 4 * 18 pcs	2Gb	E-die					Now	
1Gx 72	8GB	M393B1K73CH0	YF8/H9	H(4Rx8)	256M x 8 * 36 pcs	2Gb	C-die	8	4	78 ball FBGA	30mm	Now	
		M393B1K73DH0	YF8/H9		256M x 8 * 36 pcs	2Gb	D-die					Now	
		M393B1K73EB0	YH9		256M x 8 * 36 pcs	2Gb	E-die					Now	
		M393B1K70CH0	YF8/H9	E(2Rx4)	512M x 4 * 36 pcs	2Gb	C-die	8	2			Now	
		M393B1K70DH0	YF8/H9/K0		512M x 4 * 36 pcs	2Gb	D-die					Now	
		M393B1K70EB0	YH9/K0		512M x 4 * 36 pcs	2Gb	E-die					Now	
		M393B1G73BH0	YF8/H9/K0		B(2Rx8)	512M x 8 * 18 pcs	4Gb					B-die	8
		M393B1G70BH0	YF8/H9/K0	C(1Rx4)	1G x 4 * 18 pcs	4Gb	B-die	8	1			Now	
2Gx 72	16GB	M393B2K70DM0	YF8/H9	AB(4Rx4)	1G DDP x 4 * 36 pcs	2Gb	D-die	8	4	78 ball FBGA	30mm	Now	
		M393B2G70BH0	YF8/H9/K0	E(2Rx4)	1G x 4 * 36 pcs	4Gb	B-die	8	2			Now	
		M393B2G70CB0	YH9/K0		1G x 4 * 36 pcs	4Gb	C-die					Now	
		M393B2G70DB0	YH9/K0		1G x 4 * 36 pcs	4Gb	D-die					1Q'13	
		M393B2G73BH0	YF8/H9	H(4Rx8)	512M x 8 * 36 pcs	4Gb	B-die	8	4			Now	
4Gx 72	32GB	M393B4G70BM0	YF8/H9	AB(4Rx4)	2G DDP x 4 * 36 pcs	4Gb	B-die	8	4	78 ball FBGA	30mm	Now	

* NOTE : 1.35V product is 1.5V operatable.

4.9 240Pin DDR3 VLP Registered DIMM (1.5V Product)

240Pin DDR3 VLP Registered DIMM															
Org.	Density	Part Number	Speed	Raw Card	Composition	Comp. Version		Internal Banks	Rank	PKG	Height	Avail.	NOTE		
128Mx 72	1GB	M392B2873GB0	CF8/H9/K0/MA	K(1Rx8)	128M x 8 * 9 pcs	1Gb	G-die	8	1	78 ball FBGA	18.75mm	Now			
256Mx 72	2GB	M392B5673GB0	CF8/H9/K0/MA	L(2Rx8)	128M x 8 * 18 pcs	1Gb	G-die	8	1	78 ball FBGA	18.75mm	Now			
		M392B5670GB0	CF8/H9/K0/MA	M(1Rx4)	256M x 4 * 18 pcs	1Gb	G-die					Now			
		M392B5773CH0	CF8/H9/K0	K(1Rx8)	256M x 8 * 9 pcs	2Gb	C-die					Now			
		M392B5773DH0	CF8/H9/K0/MA		256M x 8 * 9 pcs	2Gb	D-die					Now			
512Mx 72	4GB	M392B5273CH0	CF8/H9/K0	L(2Rx8)	256M x 8 * 18 pcs	2Gb	C-die	8	2	78 ball FBGA	18.75mm	Now			
		M392B5273DH0	CF8/H9/K0/MA		256M x 8 * 18 pcs	2Gb	D-die					Now			
		M392B5270CH0	CF8/H9/K0	M(1Rx4)	512M x 4 * 18 pcs	2Gb	C-die					8	1	Now	
		M392B5270DH0	CF8/H9/K0/MA		512M x 4 * 18 pcs	2Gb	D-die							Now	
1Gx 72	8GB	M392B1K73CM0	CF8/H9	V(4Rx8)	512M DDP x 8 * 18 pcs	2Gb	C-die	8	4	78 ball FBGA	18.75mm	Now			
		M392B1K73DM0	CF8/H9		512M DDP x 8 * 18 pcs	2Gb	D-die					Now			
		M392B1K70CM0	CF8/H9/K0	N(2Rx4)	1G DDP x 4 * 18 pcs	2Gb	C-die					8	2	Now	
		M392B1K70DM0	CF8/H9/K0/MA		1G DDP x 4 * 18 pcs	2Gb	D-die							Now	
		M392B1G73BH0	CF8/H9/K0/MA	L(2Rx8)	512M x 8 * 18 pcs	4Gb	B-die					8	1	Now	
		M392B1G70BH0	CF8/H9/K0/MA	M(1Rx4)	1G x 4 * 18 pcs	4Gb	B-die							Now	
2Gx 72	16GB	M392B2G70BM0	CF8/H9/K0/MA	N(2Rx4)	2G DDP x 4 * 18 pcs	4Gb	B-die	8	2	78 ball FBGA	18.75mm	Now			
		M392B2G73BM0	CF8/H9	V(4Rx8)	1G DDP x 8 * 18 pcs	4Gb	B-die	8	4			Now			
4Gx 72	32GB	M392B4G70BE0	CF8/H9	U(4Rx4)	4G QDP x 4 * 18 pcs	4Gb	B-die	8	4	78 ball FBGA	18.75mm	Now			

4.10 240Pin DDR3 VLP Registered DIMM (1.35V Product)

240Pin DDR3 VLP Registered DIMM													
Org.	Density	Part Number	Speed	Raw Card	Composition	Comp. Version		Internal Banks	Rank	PKG	Height	Avail.	NOTE
128Mx 72	1GB	M392B2873GB0	YF8/H9/K0	K(1Rx8)	128M x 8 * 9 pcs	1Gb	G-die	8	1	78 ball FBGA	18.75mm	Now	
256Mx 72	2GB	M392B5673GB0	YF8/H9/K0	L(2Rx8)	128M x 8 * 18 pcs	1Gb	G-die	8	2	78 ball FBGA	18.75mm	Now	
		M392B5670GB0	YF8/H9/K0	M(1Rx4)	256M x 4 * 18 pcs	1Gb	G-die	8	1			Now	
		M392B5773CH0	YF8/H9	K(1Rx8)	512M x 4 * 9 pcs	2Gb	C-die	8	1			Now	
		M392B5773DH0	YF8/H9/K0		512M x 4 * 9 pcs	2Gb	D-die					Now	
512Mx 72	4GB	M392B5273CH0	YF8/H9	L(2Rx8)	256M x 8 * 18 pcs	2Gb	C-die	8	2	78 ball FBGA	18.75mm	Now	
		M392B5273DH0	YF8/H9/K0		256M x 8 * 18 pcs	2Gb	D-die					Now	
		M392B5270CH0	YF8/H9	M(1Rx4)	512M x 4 * 18 pcs	2Gb	C-die	8	1			Now	
		M392B5270DH0	YF8/H9/K0		512M x 4 * 18 pcs	2Gb	D-die					Now	
1Gx 72	8GB	M392B1K73CM0	YF8/H9	V(4Rx8)	512M DDP x 8 * 18 pcs	2Gb	C-die	8	4	78 ball FBGA	18.75mm	Now	
		M392B1K73DM0	YF8/H9		512M DDP x 8 * 18 pcs	2Gb	D-die					Now	
		M392B1K70CM0	YF8/H9	N(2Rx4)	1G DDP x 4 * 18 pcs	2Gb	C-die	8	2			Now	
		M392B1K70DM0	YF8/H9/K0		1G DDP x 4 * 18 pcs	2Gb	D-die					Now	
		M392B1G73BH0	YF8/H9/K0	L(2Rx8)	512M x 8 * 18 pcs	4Gb	B-die	8	2			Now	
		M392B1G70BH0	YF8/H9/K0	M(1Rx4)	1G x 4 * 18 pcs	4Gb	B-die	8	1			Now	
2Gx 72	16GB	M392B2G70BM0	YF8/H9/K0	N(2Rx4)	2G DDP x 4 * 18 pcs	4Gb	B-die	8	2	78 ball FBGA	18.75mm	Now	
		M392B2G73BM0	YF8/H9	V(4Rx8)	1G DDP x 8 * 18 pcs	4Gb	B-die	8	4			Now	
4Gx 72	32GB	M392B4G70BE0	YF8/H9	U(4Rx4)	4G QDP x 4 * 18 pcs	4Gb	B-die	8	4	78 ball FBGA	18.75mm	Now	

* NOTE : 1.35V product is 1.5V operatable.

4.11 240Pin DDR3 LRDIMM (1.5V Product)

240Pin DDR3 LDIMM													
Org.	Density	Part Number	Speed	Raw Card	Composition	Comp. Version		Internal Banks	Rank	PKG	Height	Avail.	NOTE
4G x 72	32GB	M386B4G70BM0	CMA	C(4Rx4)	2G DDP x 4 * 36 pcs	4Gb	B-die	8	4	78 ball FBGA	30.35mm	Now	1)
		M386B4G70DM0	CMA		2G DDP x 4 * 36 pcs	4Gb	D-die					2Q'13	
8G x 72	64GB	M386B8G70BO0	CK0	E(8Rx4)	4G QDP x 4 * 36 pcs	4Gb	B-die	8	8	78 ball FBGA	30.35mm	Now	

* NOTE

1) LRDIMM Part Number includes memory buffer digit, which is 13th. For more information, please refer to 13page.

4.12 240Pin DDR3 LRDIMM (1.35V Product)

240Pin DDR3 LDIMM																	
Org.	Density	Part Number	Speed	Raw Card	Composition	Comp. Version		Internal Banks	Rank	PKG	Height	Avail.	NOTE				
2G x 72	16GB	M386B2G70DM0	YH9/K0	C(4Rx4)	1G DDP x 4 * 36 pcs	2Gb	D-die	8	4	78 ball FBGA	30.35mm	Now	1)				
4G x 72	32GB	M386B4G70BM0	YH9/K0		2G DDP x 4 * 36 pcs	4Gb	B-die					8		4	78 ball FBGA	30.35mm	Now
		M386B4G70DM0	YH9/K0		2G DDP x 4 * 36 pcs	4Gb	D-die										2Q'13
8G x 72	64GB	M386B8G70BO0	YF8/H9	E(8Rx4)	4G QDP x 4 * 36 pcs	4Gb	B-die	8	8	78 ball FBGA	30.35mm	Now					

* NOTE

1) LRDIMM Part Number includes memory buffer digit, which is 13th. For more information, please refer to 13page.

5. RDIMM RCD Information

5.1 RCD Identification in JEDEC Description in Module Label

5.2 Label Example



5.3 RCD Information

- Example

PKG	RCD Vendor	RCD Version(Rev.)	JEDEC Description (Example - 4GB 2Rx8 PC3(L) ¹ - 12800R - 11 - 11 - B1 - XX)
1Gb F-die	IDT	HLB(B0)	D2
2Gb C-die			
4Gb A-die	Inphi	GS04(1.5V)/LV-GS02(1.35V)	P1
1Gb G-die	IDT	A1(evergreen)	D3
2Gb D-die			
4Gb B-die	Inphi	UV-GS02	P2
2Gb E-die	IDT	B1	D4
4Gb C-die			
4Gb D-die	Inphi	XV-GS02	P3

*** NOTE**

1) PC3L is used for 1.35V

2) RCD information is subject to change.

6. LRDIMM Memory Buffer Information

6.1 Label Example



6.2 Memory Buffer Information

- Example

Voltage	Vendor	Revision	Module P/N	JEDEC Description On Label
1.35V	Inphi	iMB02-GS02A	M386B4G70BM0-YH90 ¹	32GB 4Rx4 PC3L-10600L-09-11-C0
	Montage	MB C0	M386B4G70BM0-YH92 ¹	32GB 4Rx4 PC3L-10600L-09-11-C0
1.5V	Inphi	iMB02-GS02A	M386B4G70BM0-CMA3 ¹	32GB 4Rx4 PC3-14900L-13-11-C0
	IDT	A2	M386B4G70BM0-CMA1 ¹	32GB 4Rx4 PC3-14900L-13-11-C0
	Montage	MB C1	M386B4G70BM0-CMA4 ¹	32GB 4Rx4 PC3-14900L-13-11-C0

*** NOTE**

1) The 16th digit refers memory buffer vendor and revision.

0: Inphi iMB02-GS02A

1: IDT A2

2: Montage MB C0

3: Inphi iMB02-GS02B

4: Montage MB C1

2) Memory buffer information is subject to change.

7. Package Dimension

78Ball FBGA for 2Gb C-die (x4/x8) / 2Gb D-die (x4/x8)

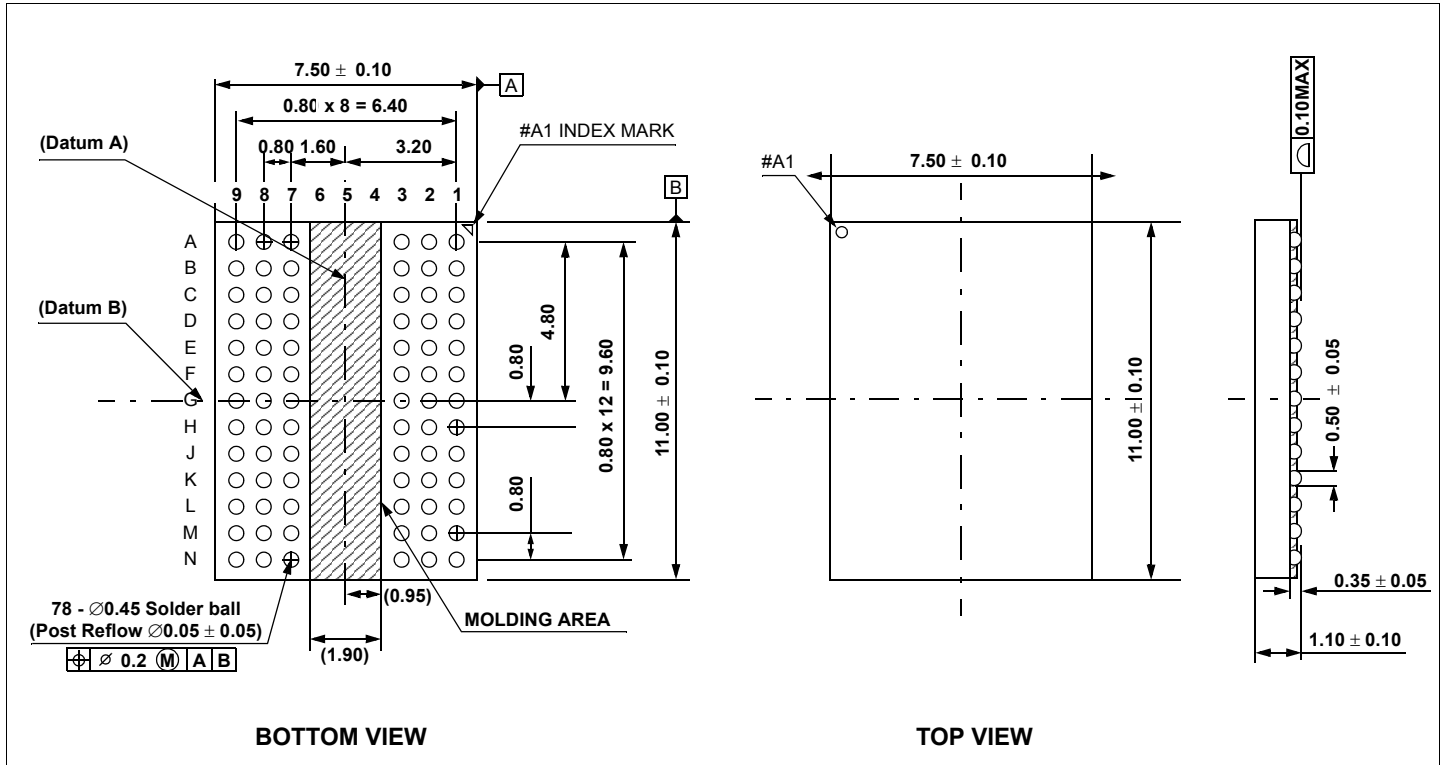

78Ball FBGA Flip chip for 2Gb E-die (x4/x8)

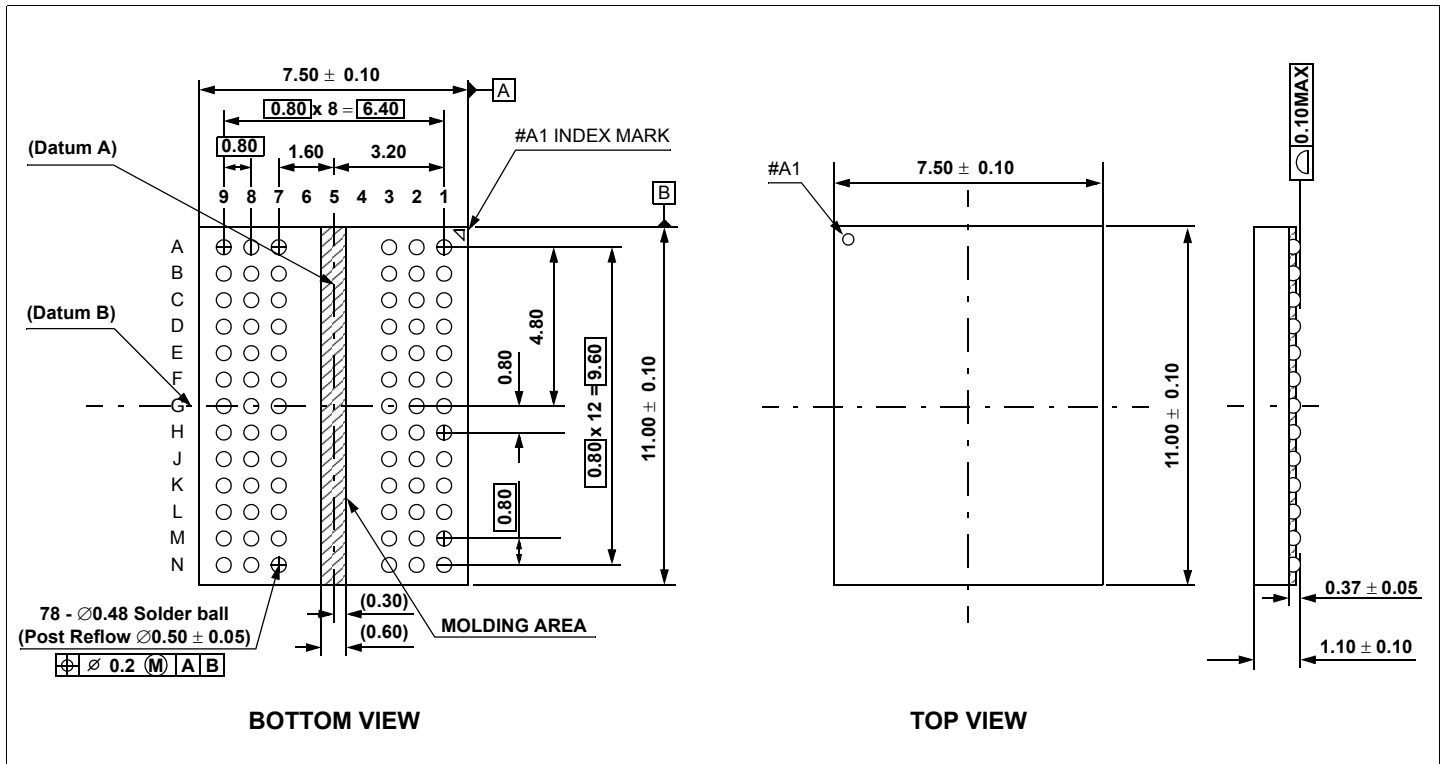

78Ball DDP for 4Gb A-die (x4/x8)

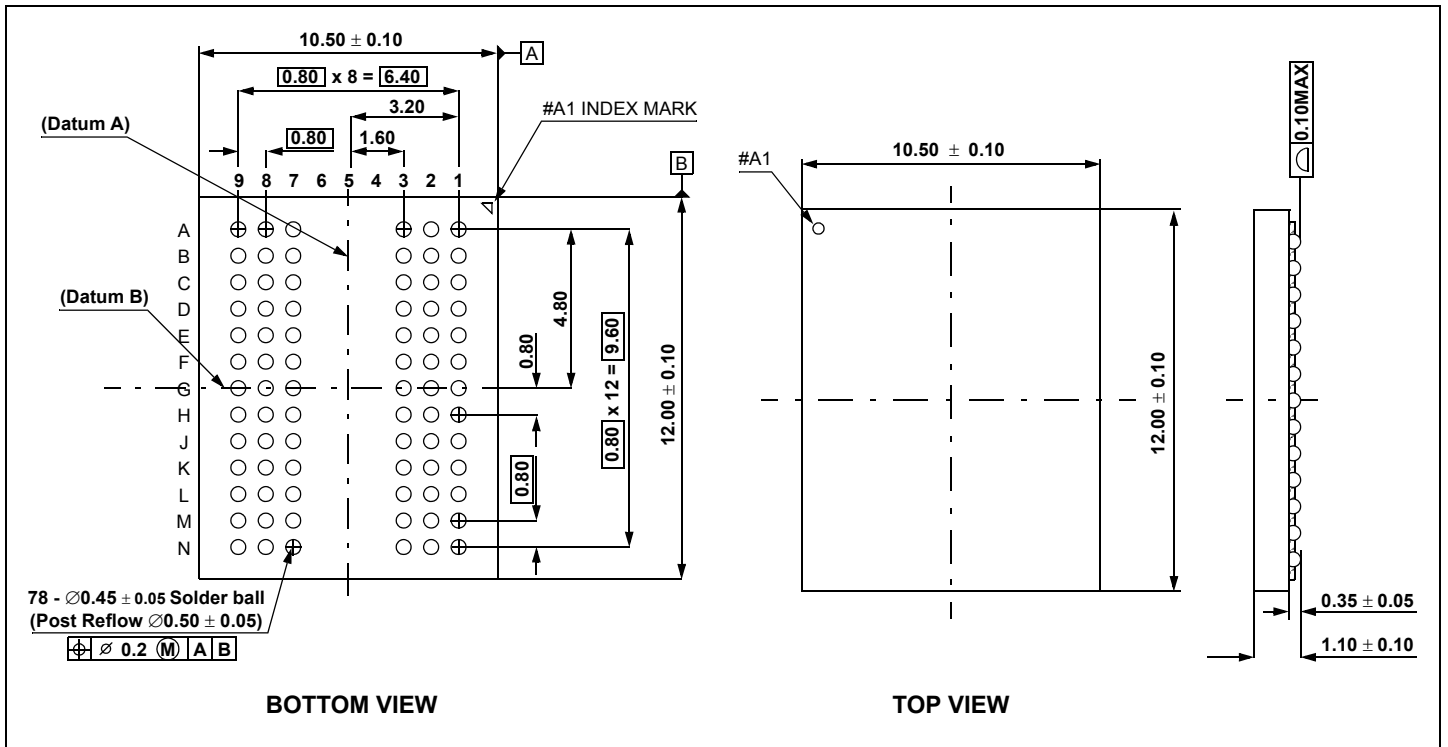

78Ball DDP for 4Gb B-die (x4/x8)

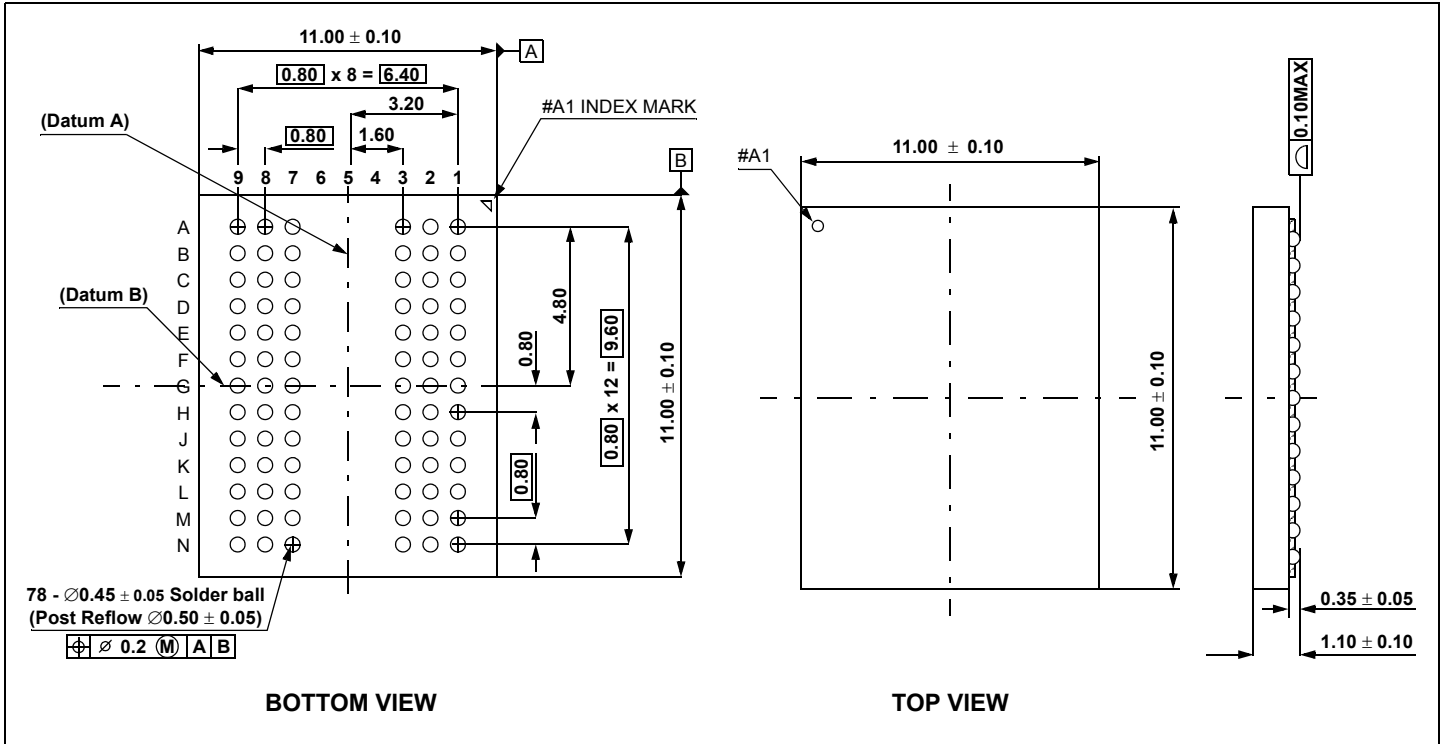

78Ball FBGA for 4Gb B-die (x4/x8)

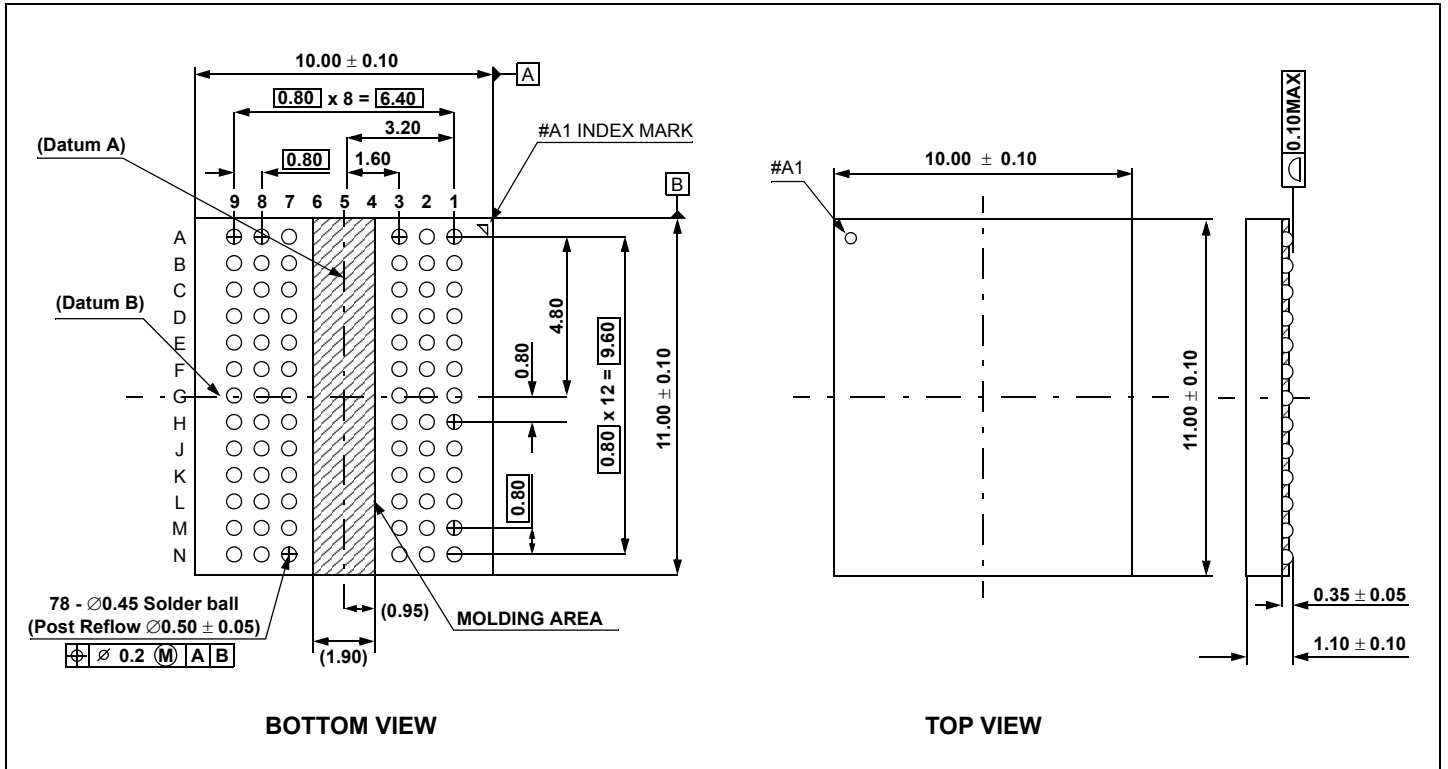

78Ball FBGA for 4Gb C-die (x4/x8)

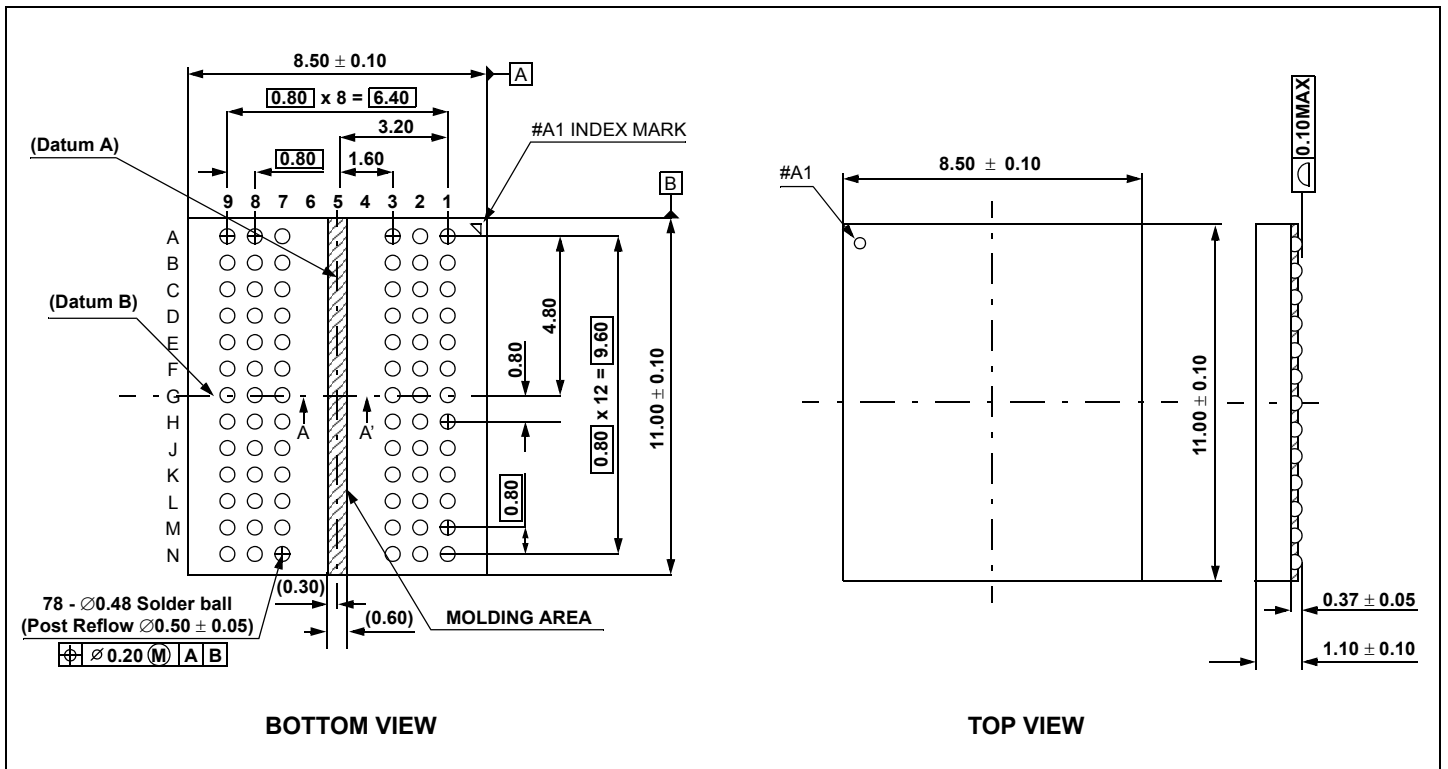

78Ball FBGA for 4Gb D-die (x4/x8)

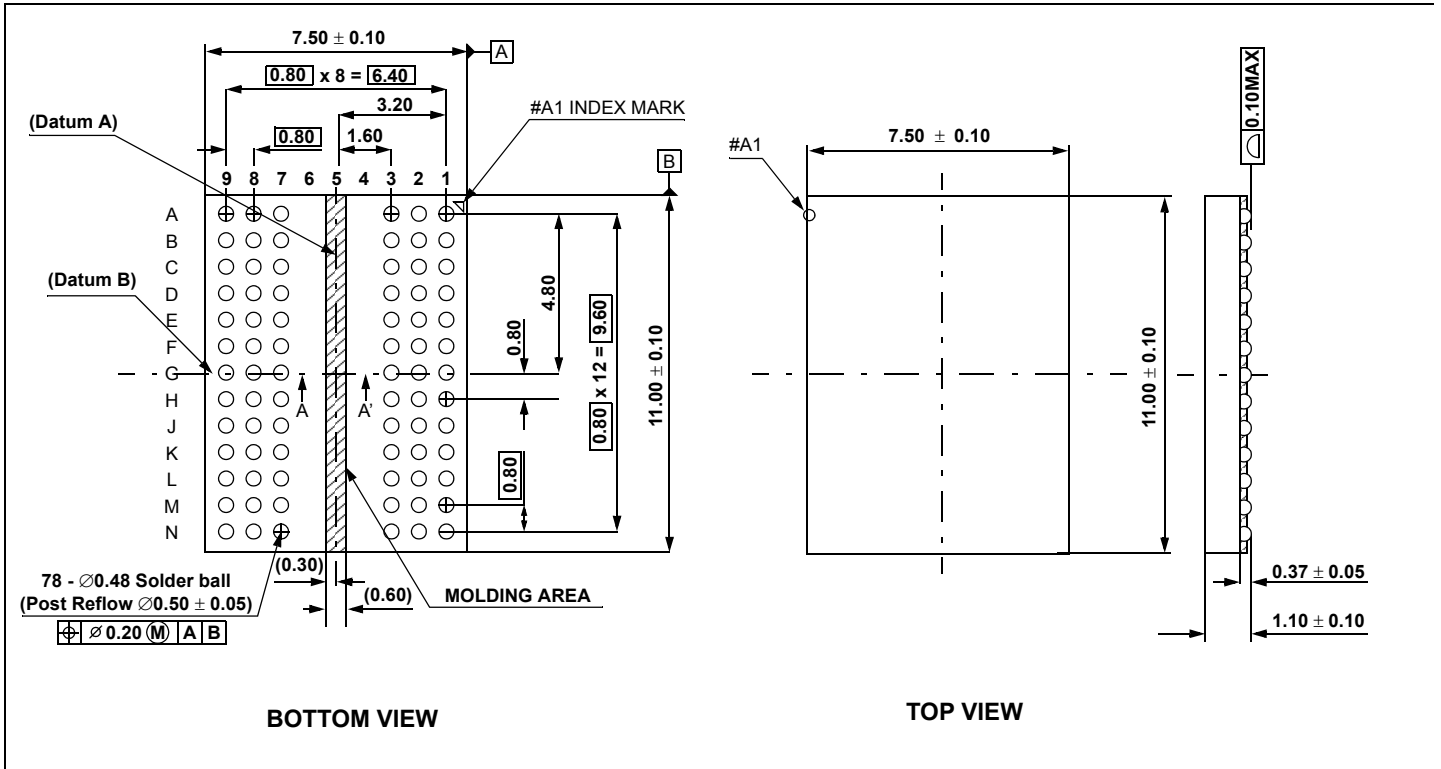

78Ball FBGA Flip chip for 1Gb G-die (x4/x8)

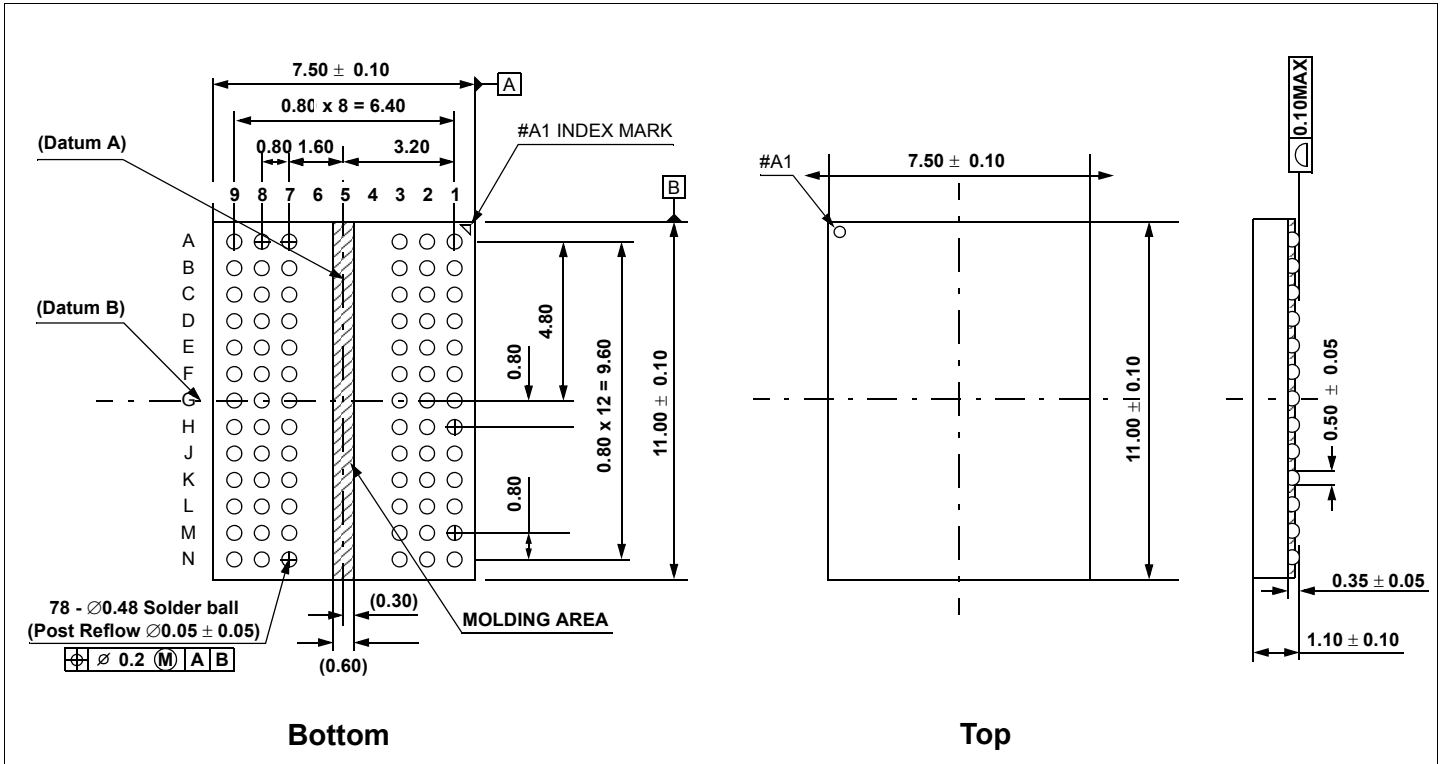

8. Module Dimension

x64/x72 240pin DDR3 SDRAM Unbuffered DIMM

Units : Millimeters

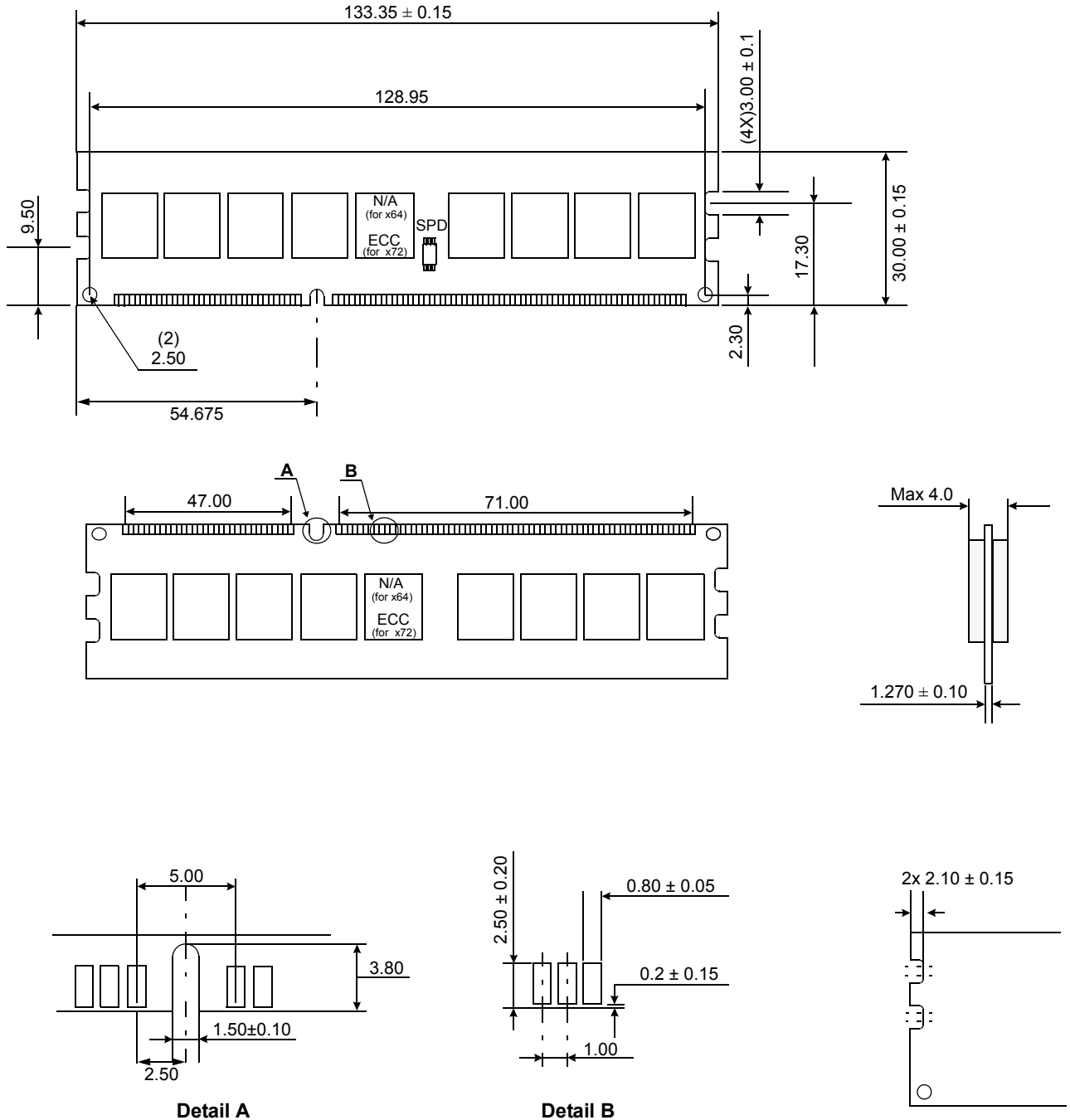

x72 240pin DDR3 SDRAM ECC VLP UDIMM

Units : Millimeters

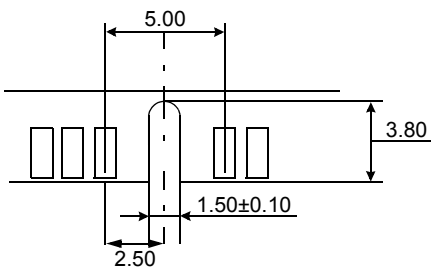
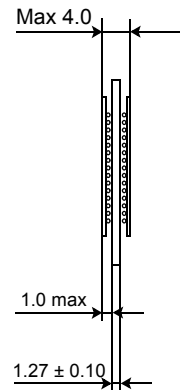
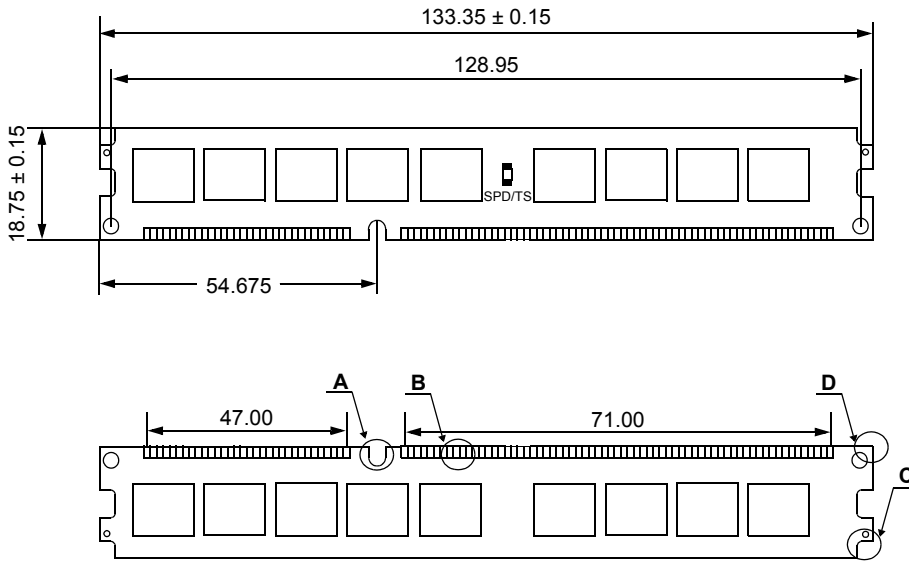

Detail A

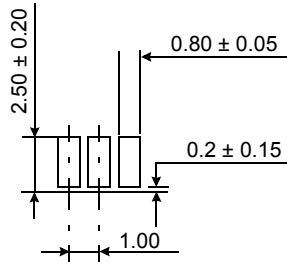

Detail B

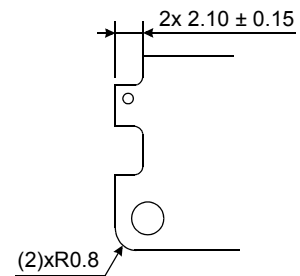

Detail C & D

x64 204pin DDR3 SDRAM Unbuffered SODIMM

Units : Millimeters

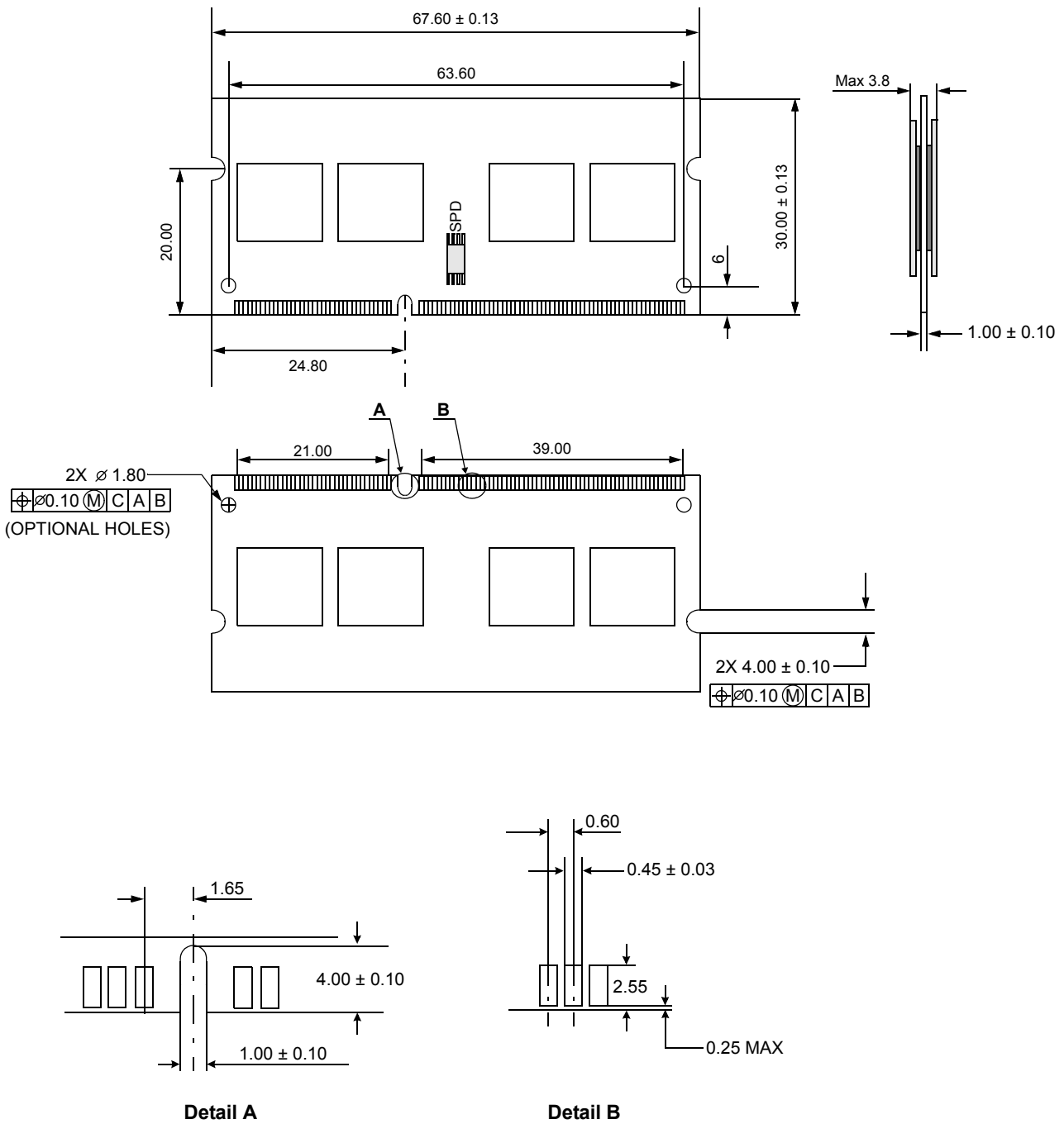

x72 204 pin DDR3 SDRAM ECC Unbuffered SODIMM

Units : Millimeters

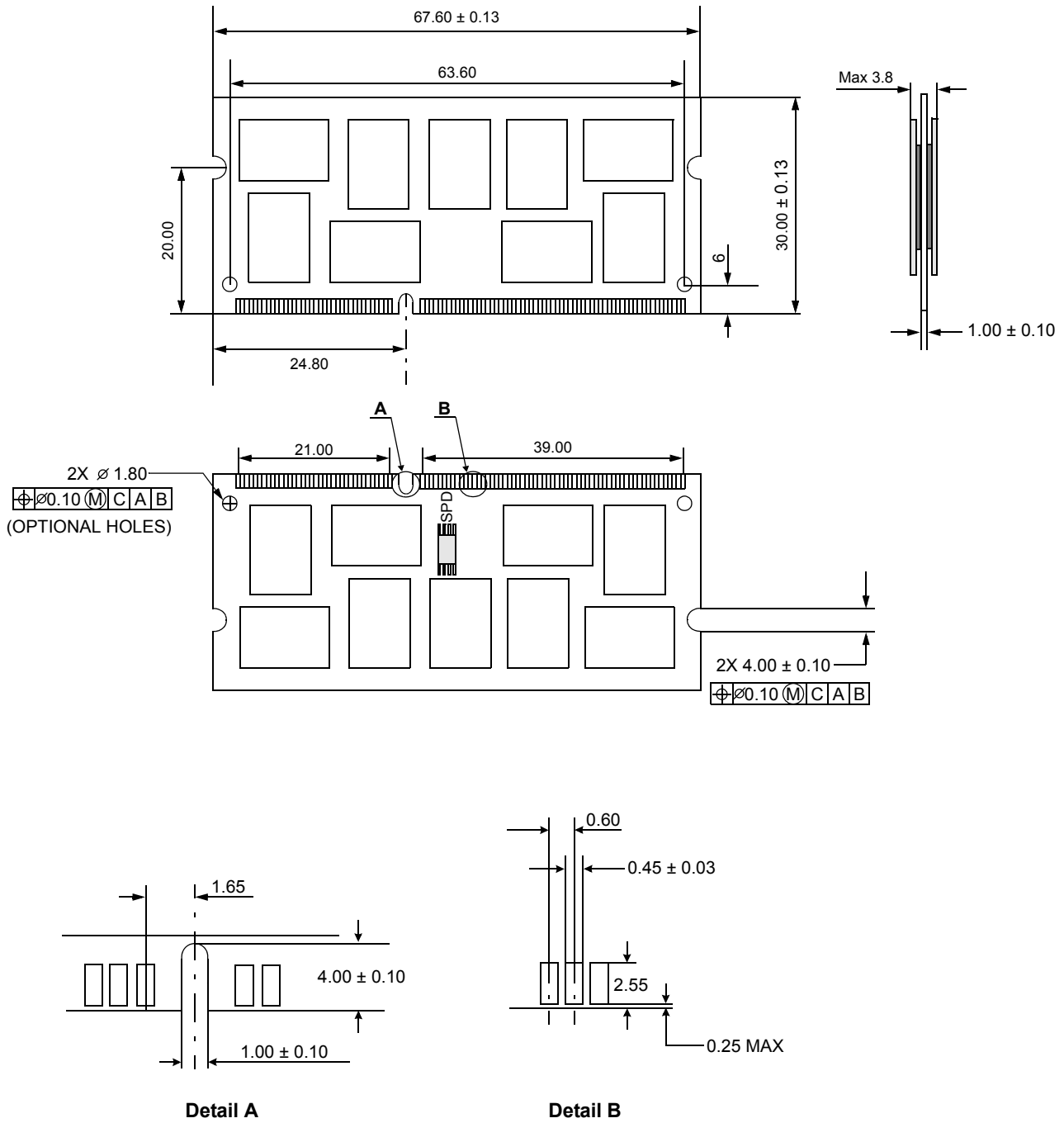

x72 240pin DDR3 SDRAM Registered DIMM

Units : Millimeters

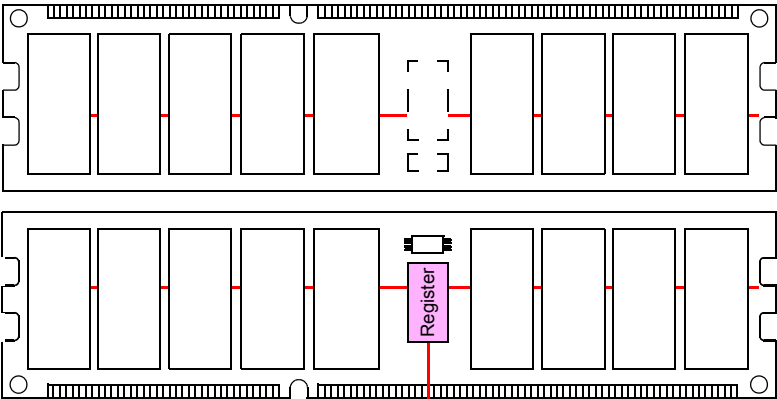
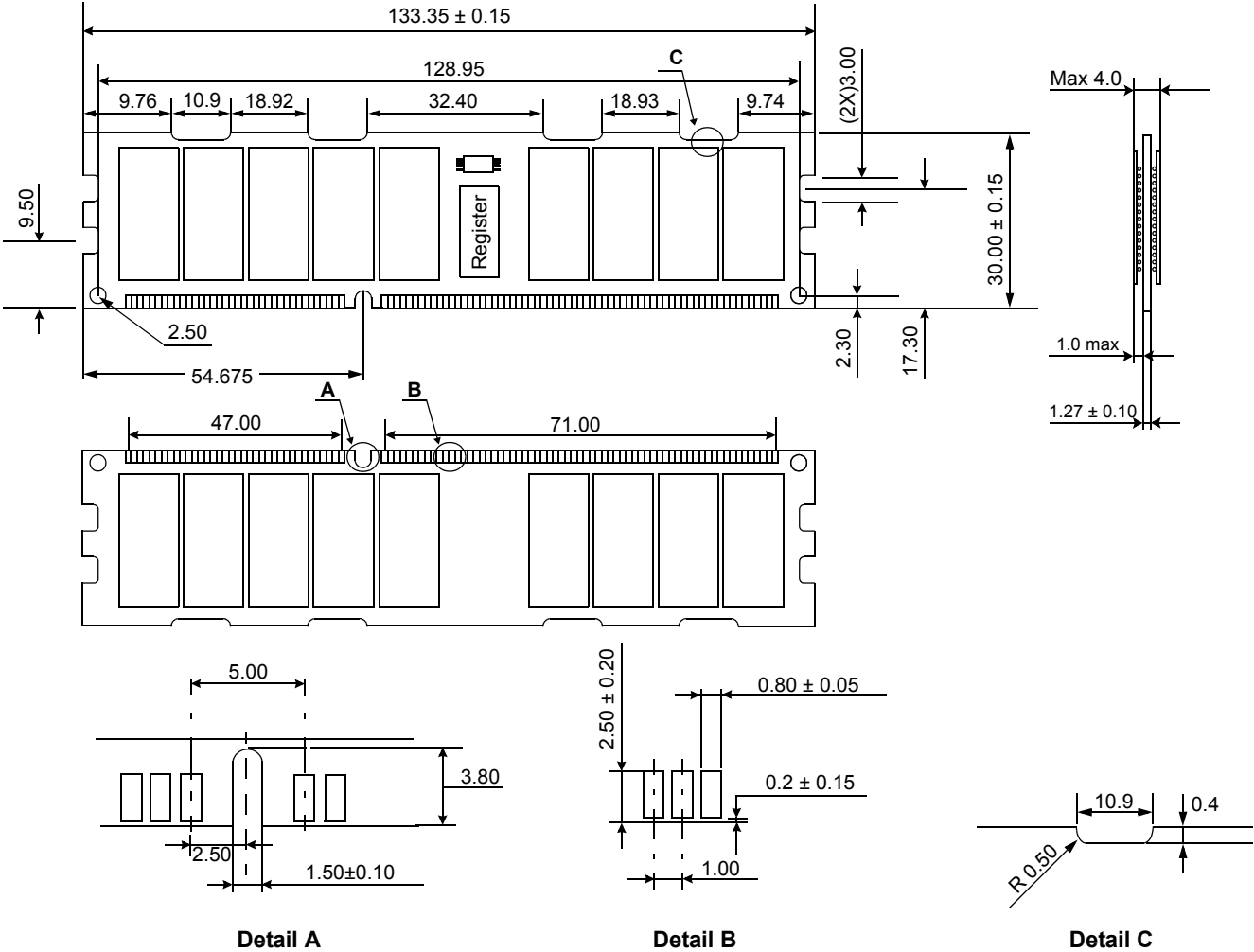

— Address, Command and Control lines

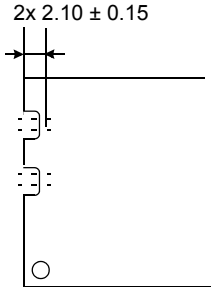

Registered DIMM Heat Spreader Design

1. FRONT PART

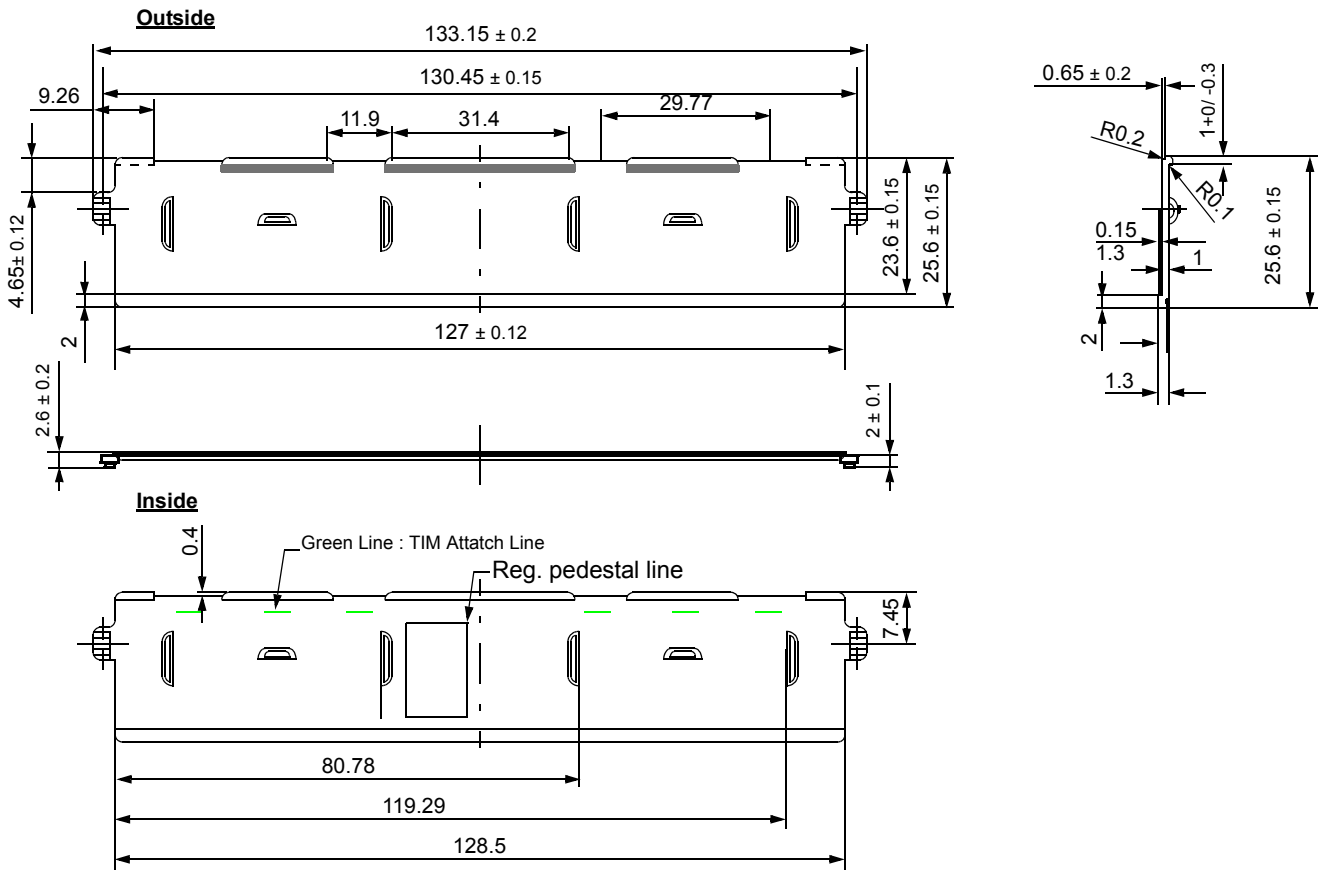

2. BACK PART

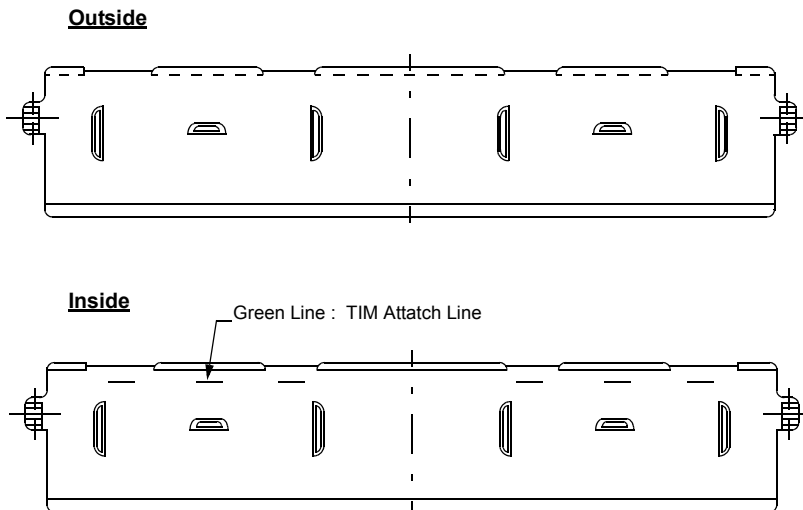

3. CLIP PART

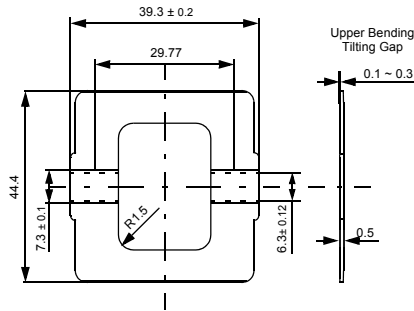

4. DDR3 RDIMM ASS'Y View

Reference thickness total (Maximum) : 7.55mm (With Clip thickness)

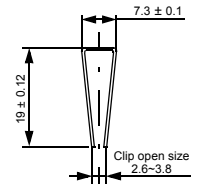
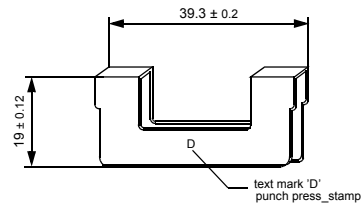
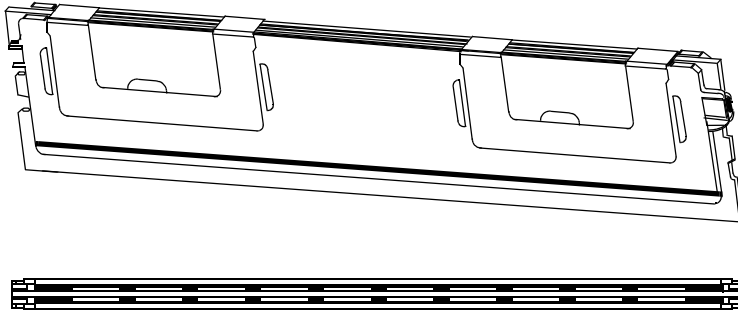
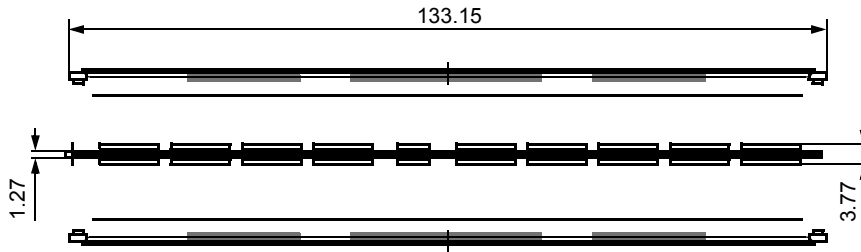

x72 240pin DDR3 SDRAM VLP Registered DIMM

Units : Millimeters

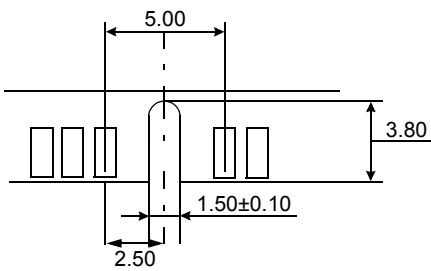
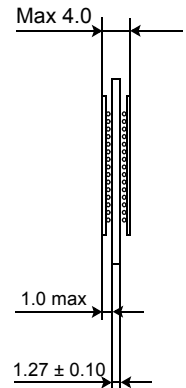
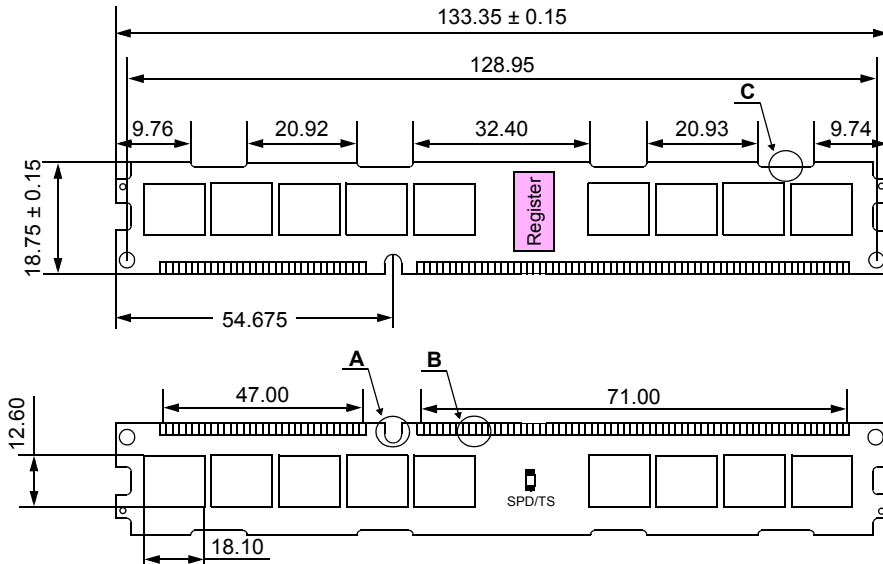

Detail A

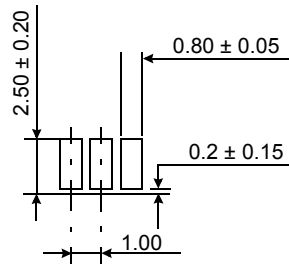

Detail B

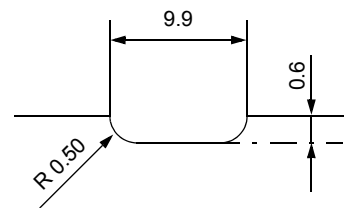

Detail C

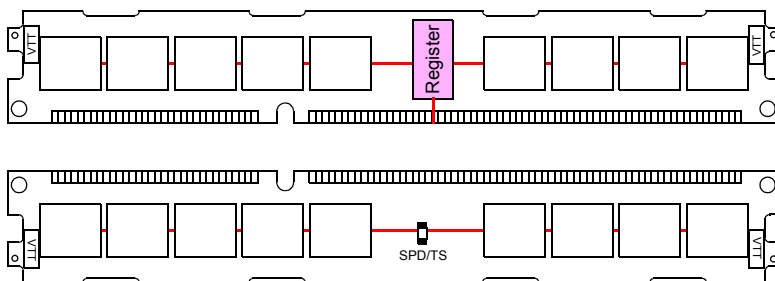

— Address, Command and Control lines

VLP Registered DIMM Heat Spreader Design (DDP)

1. FRONT PART

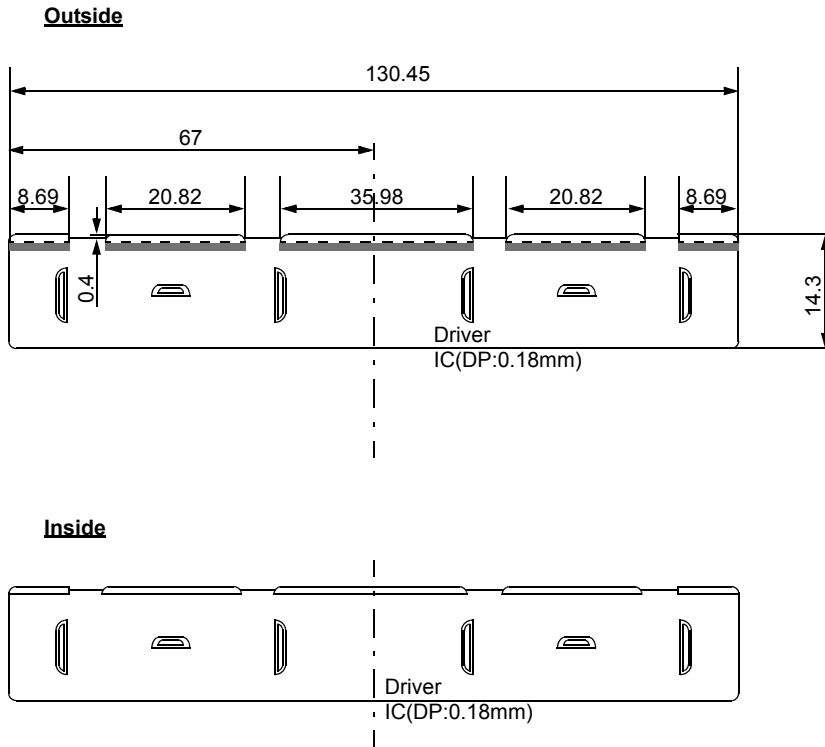

2. BACK PART

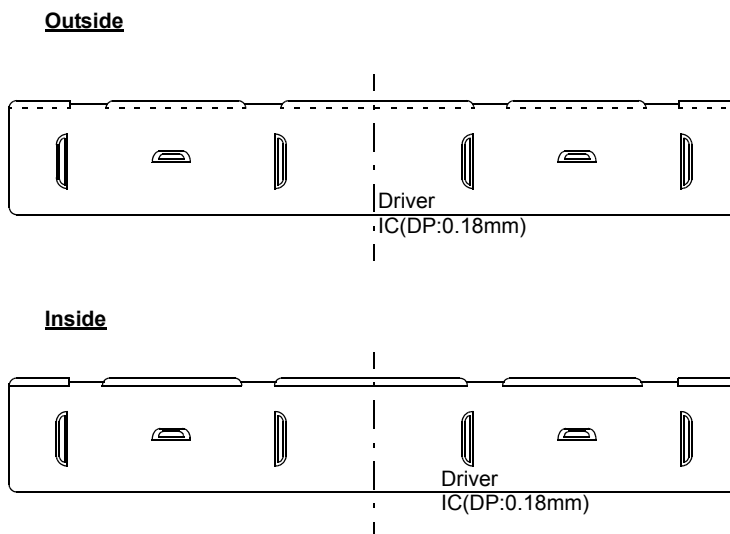

3. CLIP PART

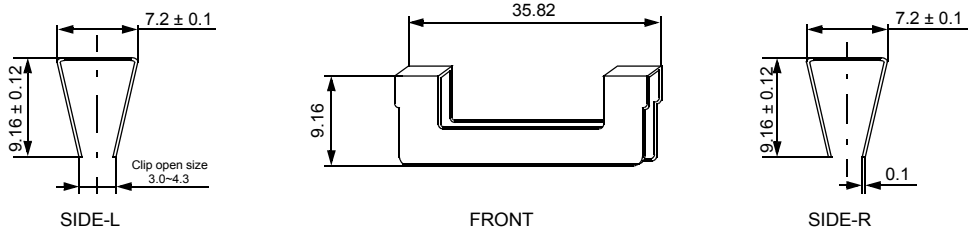

4. ASS'Y VIEW

Reference thickness total (Maximum) : 7.55 (With Clip thickness)

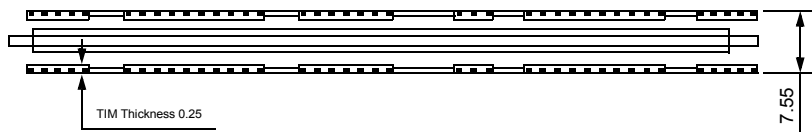

3. CLIP PART

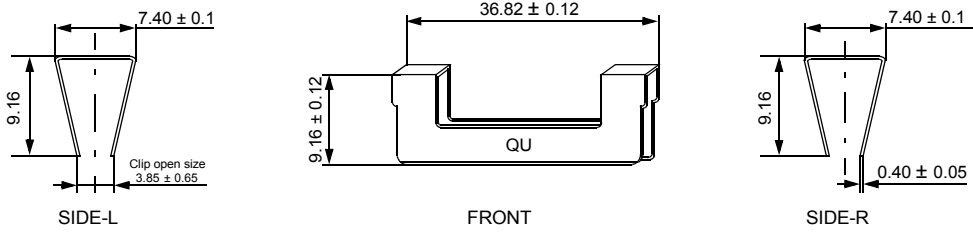

4. ASS'Y VIEW

Reference thickness total (Maximum) : 8 (With Clip thickness)

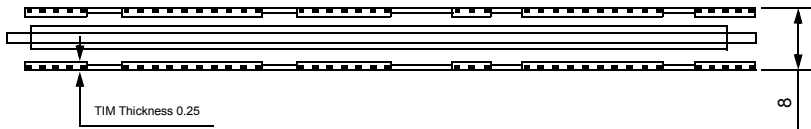

x72 244pin DDR3 SDRAM Mini DIMM

Units : Millimeters

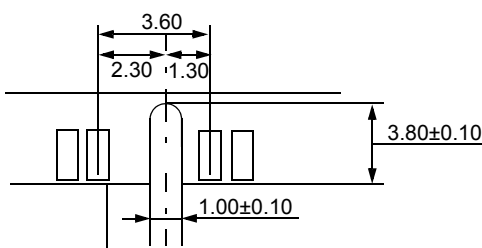
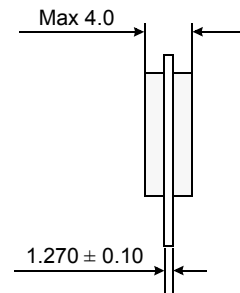
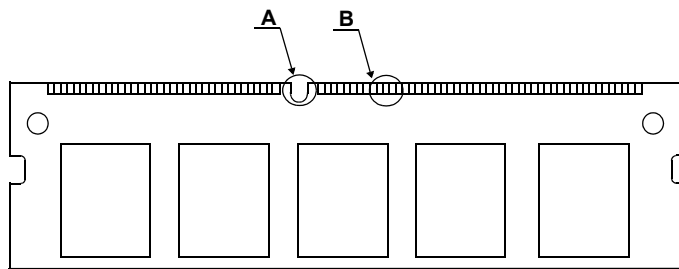
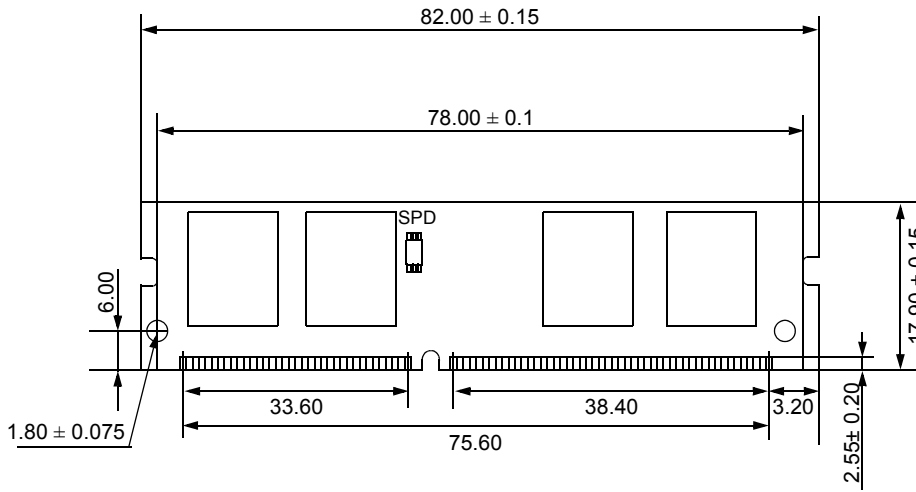

Detail A

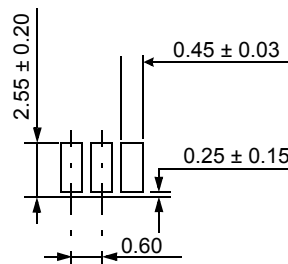

Detail B

