

Vectron International**Filter specification****TFS 416A****1/5****Measurement condition**

Ambient temperature:	23	°C
Input power level:	0	dBm
Terminating impedance:		
Input:	150 Ω	
Output:	150 Ω	

Characteristics

Remark:

The nominal frequency f_N is fixed at 416.0 MHz. The insertion loss a_e is defined as loss value determined at f_N . Reference level for the absolute attenuation a_{abs} of the TFS 416A is the insertion loss a_e . All specified data are met within the operating temperature range.

Data		typ. value		tolerance / limit		
Insertion loss	a_e	2.2	dB	max.	3.5	dB
Nominal frequency	f_N				416.0	MHz
Centre frequency	f_C	416.0	MHz			
Bandwidth	BW					
3 dB		14.4	MHz		-	
Absolute attenuation	a_{abs}					
f_N - 1.28 MHz		2.8	dB	max.	4.5	dB
f_N - 51.8 MHz		63	dB	min.	50	dB
f_N - 52.0 MHz		63	dB	min.	50	dB
f_N - 103.68 MHz		74	dB	min.	50	dB
f_N - 104.00 MHz		72	dB	min.	50	dB
f_N - 155.52 MHz		73	dB	min.	50	dB
f_N - 156.00 MHz		74	dB	min.	50	dB
f_N - 207.36 MHz		71	dB	min.	50	dB
f_N - 208.00 MHz		74	dB	min.	50	dB
f_N - 259.20 MHz		79	dB	min.	51	dB
f_N - 260.00 MHz		67	dB	min.	51	dB
f_N - 311.04 MHz		70	dB	min.	51	dB
f_N - 312.00 MHz		76	dB	min.	51	dB
f_N - 362.88 MHz		73	dB	min.	52	dB
f_N - 364.00 MHz		65	dB	min.	52	dB
f_N + 51.8 MHz		61	dB	min.	48	dB
f_N + 52.0 MHz		62	dB	min.	48	dB
f_N + 103.68 MHz		68	dB	min.	48	dB
f_N + 104.00 MHz		65	dB	min.	48	dB
f_N + 155.52 MHz		70	dB	min.	48	dB
f_N + 156.00 MHz		73	dB	min.	48	dB
f_N + 207.36 MHz		63	dB	min.	48	dB
f_N + 208.00 MHz		56	dB	min.	48	dB
f_N + 259.20 MHz		72	dB	min.	49	dB
f_N + 260.00 MHz		72	dB	min.	49	dB
f_N + 311.04 MHz		67	dB	min.	50	dB
f_N + 312.00 MHz		68	dB	min.	50	dB
f_N + 362.88 MHz		70	dB	min.	50	dB
f_N + 364.00 MHz		66	dB	min.	50	dB
Input power level		-		max.	5	dBm
Operating temperature range	OTR	-			-40 °C ... +85 °C	
Storage temperature range		-			-45 °C ... +95 °C	
Temperature coefficient of frequency	TC_f *	-72	ppm/K			

*) $\Delta f_C(\text{Hz}) = TC_f(\text{ppm/K}) \times (T - T_0) \times f_{CAT}(\text{MHz})$. Material: LiNbO3_64° black, so in principle pyrofree.

Generated:**Checked / Approved:**

Vectron International GmbH
Potsdamer Straße 18
D 14 513 TELTOW / Germany
Tel: (+49) 3328 4784-0 / Fax: (+49) 3328 4784-30
E-Mail: tft@vectron.com

Vectron International GmbH reserves the right to make changes to the product(s) and/or information contained herein without notice. No liability is assumed as a result of their use or application. No rights under any patent accompany the sale of any such product(s) or information.

Filter characteristic

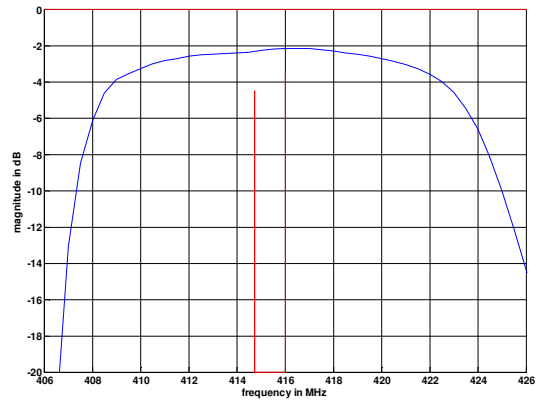
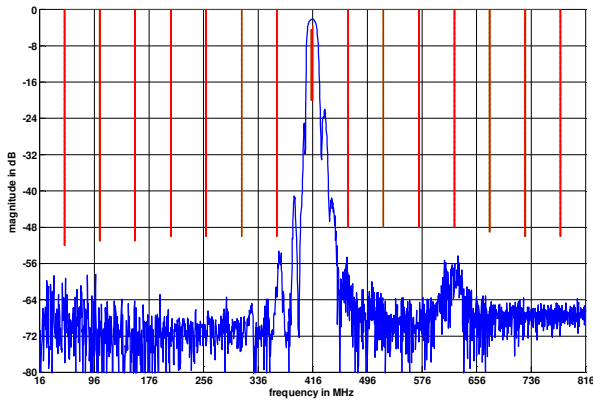

Construction and pin connection

(All dimensions in mm)

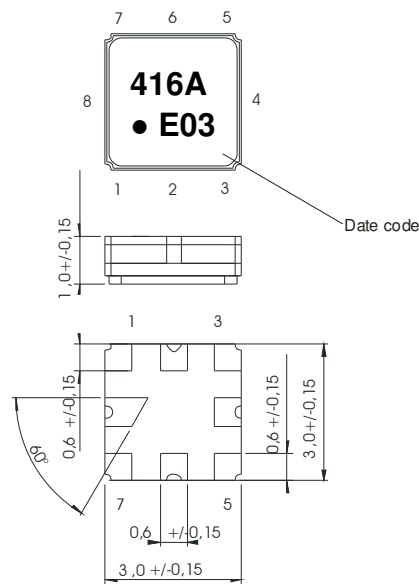

- 1 Ground
- 2 Input
- 3 Ground
- 4 Ground
- 5 Ground
- 6 Output
- 7 Ground
- 8 Ground

Date code: Year + week
 E 2014
 F 2015
 G 2016
 ...

150 Ω Test circuit

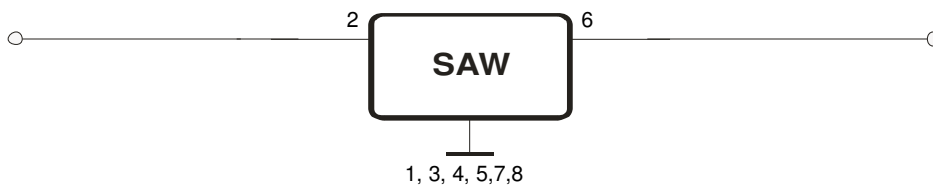

Vectron International GmbH
 Potsdamer Straße 18
 D 14 513 TELTOW / Germany
 Tel: (+49) 3328 4784-0 / Fax: (+49) 3328 4784-30
 E-Mail: tft@vectron.com

Vectron International GmbH reserves the right to make changes to the product(s) and/or information contained herein without notice. No liability is assumed as a result of their use or application. No rights under any patent accompany the sale of any such product(s) or information.

Stability characteristics, reliability

After the following tests the filter shall meet the whole specification:

1. Shock: 500g, 1 ms, half sine wave, 3 shocks each plane;
DIN IEC 68 T2 - 27
2. Vibration: 10 Hz to 500 Hz, 0.35 mm or g respectively, 1 octave per min, 10 cycles per plane, 3 planes; DIN IEC 68 T2 - 6
3. Change of temperature: -55 °C to 125°C / 15 min. each / 100 cycles
DIN IEC 68 part 2 – 14 Test N
4. Resistance to solder heat (reflow): reflow possible: three times max.;
for temperature conditions, see page 4: "Air reflow temperature conditions"

This filter is RoHS compliant (2011/65/EU)

Packing

Tape & Reel: IEC 286 – 3, with exception of value for N and minimum bending radius;
tape type II, embossed carrier tape with top cover tape on the upper side;

max. pieces of filters per reel:	3000
reel of empty components at start:	min. 300 mm
reel of empty components at start including leader:	min. 500 mm
trailer:	min. 300 mm

Tape (all dimensions in mm)

- W : 8,00 ± 0,3
- Po : 4,00 ± 0,1
- Do : 1,50 +0,1/-0
- E : 1,75 ± 0,1
- F : 3,50 ± 0,05
- G(min) : 0,75
- P2 : 2,00 ± 0,05
- P1 : 4,00 ± 0,1
- D1(min) : 1,50
- Ao : 3,25 ± 0,1
- Bo : 3,25 ± 0,1
- Ct : 5,3 ± 0,1

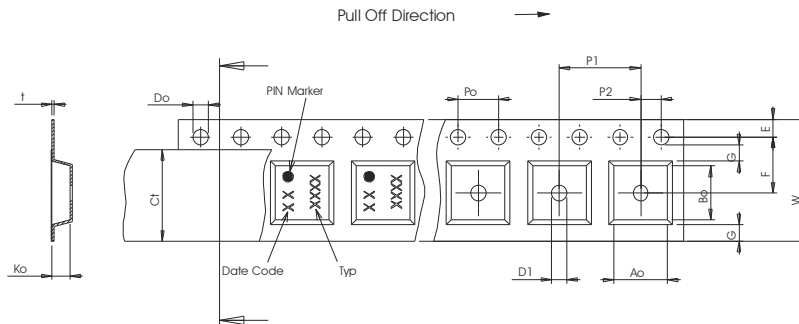

Reel (all dimensions in mm)

- A : 180
- W1 : 8,4 +1,5/-0
- W2(max) : 14,4
- N(min) : 60
- C : 13,0 ± 0,2

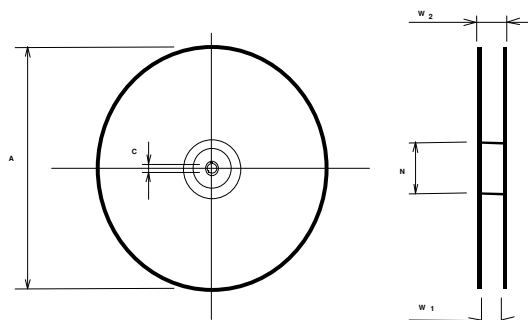

The minimum bending radius is 45 mm.

Vectron International GmbH
Potsdamer Straße 18
D 14 513 TELTOW / Germany
Tel: (+49) 3328 4784-0 / Fax: (+49) 3328 4784-30
E-Mail: tft@vectron.com

Vectron International GmbH reserves the right to make changes to the product(s) and/or information contained herein without notice. No liability is assumed as a result of their use or application. No rights under any patent accompany the sale of any such product(s) or information.

Air reflow temperature conditions

Conditions	Exposure
Average ramp-up rate (30°C to 217°C)	less than 3°C/second
> 100°C	between 300 and 600 seconds
> 150°C	between 240 and 500 seconds
> 217°C	between 30 and 150 seconds
Peak temperature	max. 260°C
Time within 5°C of actual peak temperature	between 10 and 30 seconds
Cool-down rate (Peak to 50°C)	less than 6°C/second
Time from 30°C to Peak temperature	no greater than 300 seconds

Chip-mount air reflow profile

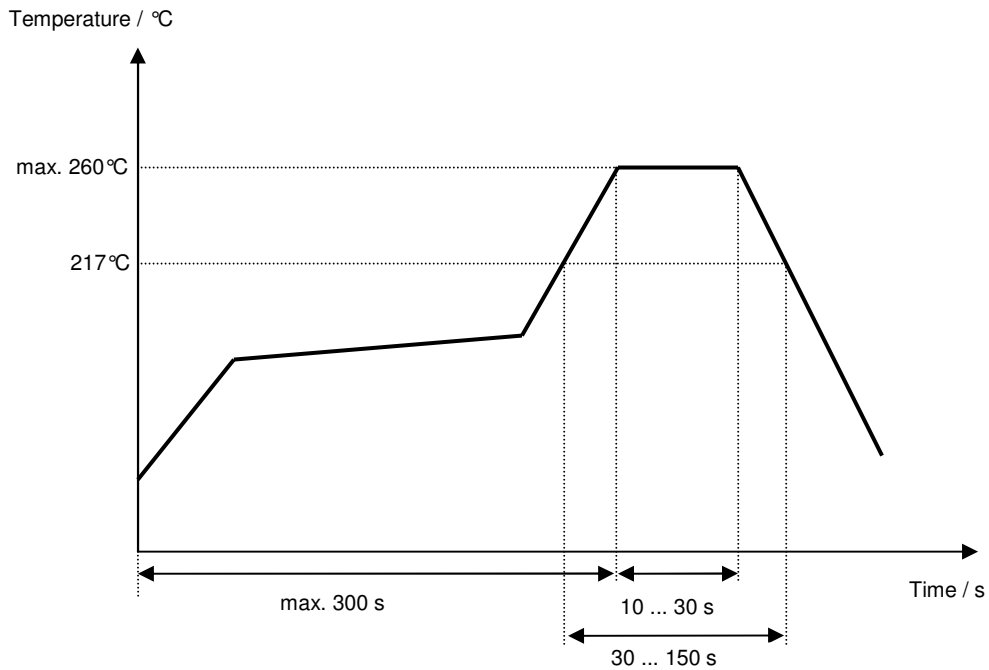

Vectron International GmbH
 Potsdamer Straße 18
 D 14 513 TELTOW / Germany
 Tel: (+49) 3328 4784-0 / Fax: (+49) 3328 4784-30
 E-Mail: tft@vectron.com

Vectron International GmbH reserves the right to make changes to the product(s) and/or information contained herein without notice. No liability is assumed as a result of their use or application. No rights under any patent accompany the sale of any such product(s) or information.

History

Version	Reason of Changes	Name	Date
1.0	Generation of development specification.	Schönbein	29.08.2012
1.1	Generation of filter specification.	Schönbein	07.09.2012
1.2	Remark on pyrofree material added to data table Changed caption on matching circuit from 50 Ω test circuit to 150 Ω test circuit	Schönbein	25.04.2013
1.3	maximum input power updated	Kortenbeutel	16.01.2014

Vectron International GmbH
Potsdamer Straße 18
D 14 513 TELTOW / Germany
Tel: (+49) 3328 4784-0 / Fax: (+49) 3328 4784-30
E-Mail: tft@vectron.com

Vectron International GmbH reserves the right to make changes to the product(s) and/or information contained herein without notice. No liability is assumed as a result of their use or application. No rights under any patent accompany the sale of any such product(s) or information.