

SparX-G8™ – 8-port Integrated Gigabit Ethernet Switch SoC with Copper PHYs

VSC7388 SparX-G8™ is the most highly integrated, single-chip Gigabit Ethernet switch with eight Integrated GbE Copper PHY ports. As part of Vitesse's SparX™ Family of switches, SparX-G8 delivers high performance with easy migration paths, and comprehensive System Solutions that enable ultra-short time-to-market and market leading system cost.

A Vitesse Switch Family Member

SparX-G8 is a part of the Vitesse SparX™ Family of Unmanaged or web-managed Switches and takes the family into a new generation of integration. With its eight tri-speed Gigabit Ethernet copper ports, it is specifically targeted at SMB and SOHO unmanaged applications, and with its on-chip 8051 and Parallel CPU interface it enables web-managed and managed switch applications.

Being a member of the switch family provides a number of unique advantages when designing with the chip, including nearly 100% software compatibility between members. Thus, software written for SparX-G8 can easily be used with other switch configurations in the family, and vice-versa.

Additionally, building a product family is easy when designing with Vitesse switches. Upgrading designs to higher port counts, or migrating to other configurations or future technology is achievable with minimum effort and time.

The Vitesse SparX™ Family of Switches

SparX-G8, as part of the Vitesse SparX Family of Switches, shares the unique traits of the family.

The highly integrated switches require no external memory, and the integration of copper PHY as well as internal oscillator circuit simplifies PCB layout to reduce time and cost. Further trimming down system cost is the industry's lowest power, fully integrated, Switch-plus-Copper PHY technology.

The switches provide for high performance designs with their non-blocking, wire-speed performance, which includes wirespeed MAC address learning.

Designing both unmanaged and web-managed solutions is straightforward. The chips offer both internal 8051 and serial and parallel CPU interfaces, and support a host of management protocols such as GxRP, SNMP, and three flavors of Spanning Tree: Standard STP, Multiple STP, and Rapid STP.

Controlling networks operated by the Vitesse switches is simple; advanced classification with IPv4 and IPv6 support, along with port DSCP remarking and 802.1X authentication support, provide flexible QoS operation. This is backed up by Layer 2-4 link aggregation and VLAN support, enabling managed switches to be deployed.

APPLICATIONS

- 8-port unmanaged Gigabit Ethernet SMB/SOHO switch
- 8-port web-managed Gigabit Ethernet SMB/SOHO switch

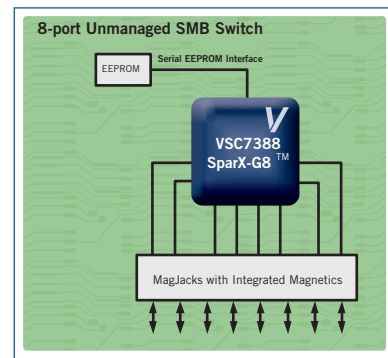

With its unique low power dissipation the VSC7388 enables fan less operation and thereby provides for higher system reliability and lower noise, both to the benefit of the user.

Designing with Vitesse SparX Family of Switches means designing with the complete Vitesse Solution: Vitesse provides a comprehensive, web-managed switch software system for the on-chip 8051 CPU. This is in addition to the unmanaged and smart managed software systems for 8051, which are also included. For homegrown software development, Vitesse's full platform and OS independent switch API are supplied.

Accompanying the software systems are the Vitesse Switch Reference Systems. These are production-ready hardware designs that also serve as evaluation platforms.

The Vitesse Solution is supplied with a comprehensive collateral package, including software source code, full documentation, and an in-depth qualification report for easy pre-evaluation.

Features

- 8 Gigabit Ethernet ports with non-blocking wire-speed performance
- 8 tri-speed (10/100/1000 Mbps) copper transceivers (IEEE 802.3ab compliant) with two optional multiplexed tri-speed (RGMII/GMII) interfaces
- 144 KB on-chip frame buffer
- Selection between on-chip 8051 CPU or off-chip 8-bit CPU for fully managed applications
- DSCP remarking for both IPv4 and IPv6 frames
- Jumbo frame support in all three speeds (10/100/1000 Mbps)
- Programmable classifier for QoS, including IEEE 802.1p and DSCP for IPv4 and IPv6, with four classes of service
- 8K MAC addresses and 4K VLANs (IEEE 802.1)
- Flexible link aggregation compliant to IEEE 802.3ad
- Full duplex flow control (IEEE 802.3X) and half duplex back pressure, symmetric and asymmetric
- Multicast and broadcast storm control as well as flooding control
- Multiple Protocol Support: IEEE 802.1D, IEEE 802.1w, IEEE 802.1s and IEEE 802.1X
- Integrated oscillator circuit
- Vitesse VeriPHY™ cable diagnostics and SimpliPHY™ magnetics technology

Benefits

- Ensures maximum data throughput in highly loaded networks
- Reduces the need for any PHY components thereby significantly reducing overall systems cost
- Eliminates the need for external buffer memory while maintaining high peak load performance
- Enables advanced switch management using run-time protocols, in addition to low cost unmanaged and web-managed operation
- Enables LAN Edge products to generate standard priority which can be used in the Core Network
- Connects effortlessly to networks, hosts, and controllers that utilize up to 9.6K sized jumbo frames
- Optimizes network performance to support any digital stream, from internet browsing to VoIP and video
- Stores a large amount of stations at wire-speed in the on-chip MAC table, ensuring optimal network performance
- Provides high bandwidth uplinking abilities
- Ensures loss-less data transmission while supporting existing legacy Ethernet equipment
- Eliminates unwanted flooding of ports and thereby increases overall network performance
- Supports complex network topologies with fast failure recovery and access control
- Simplifies design and reduces overall system cost
- Enables real time cable diagnostics and low-cost magnetics with only four or eight cores per port

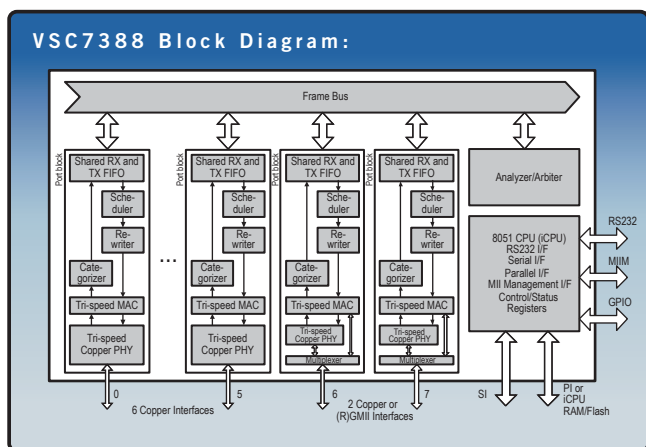

Related Vitesse Products

Visit www.vitesse.com for information about other related Vitesse products.



741 Calle Plano • Camarillo, CA 93012 USA • Tel: +1.800.VITESSE • +1.805.388.3700 • Fax: +1.805.987.5896 • www.vitesse.com

Vitesse Semiconductor Corporation