

Measurement condition

Ambient temperature:	23	°C
Input power level:	0	dBm
Terminating impedance: *		
Input:	146 Ω -0.9 pF	
Output:	146 Ω -0.9 pF	

Characteristics

Remark:

The reference level for the relative attenuation a_{rel} of the TFS1220 is the minimum of the pass band attenuation a_{min} . The minimum of the pass band attenuation a_{min} is defined as the insertion loss a_e . The centre frequency f_c is the arithmetic mean value of the upper and lower frequencies at the 3dB filter attenuation level relative to the insertion loss a_e . The nominal frequency f_N is fixed at 1220MHz without any tolerance. The given values for both the relative attenuation a_{rel} and the group delay ripple have to be achieved at the frequencies given below even if the centre frequency f_c is shifted due to the temperature coefficient of frequency TC_f in the operating temperature range and due to a production tolerance for the centre frequency f_c .

D a t a		typ. value		Variation/ Limitation
Insertion loss (reference level)	$a_e = a_{min}$	4.0	dB	max. 6 dB
Nominal frequency	f_N	-		1220 MHz
Centre frequency	f_c	1220	MHz	
Passband ripple (P-P) within $f_N \pm 100$ KHz		0.4	dB	max 1 dB
Group delay ripple within $f_N \pm 100$ KHz		43	ns	max. 100 ns
Relative attenuation	a_{rel}			
f_N $f_N \pm 0.1$ MHz		0.4	dB	max. 1 dB
$f_N \pm 4$ MHz $f_N \pm 5$ MHz		25	dB	min. 10 dB
$f_N \pm 5$ MHz $f_N \pm 6$ MHz		28	dB	min. 12 dB
$f_N \pm 6$ MHz $f_N \pm 20$ MHz		37	dB	min. 14 dB
$f_N + 20$ MHz $f_N + 180$ MHz		35	dB	min. 30 dB
$f_N - 20$ MHz $f_N - 1150$ MHz		45	dB	min. 30 dB
Input power level				max. 10 dBm
Temperature coefficient of frequency	TC_f **	-0.05	ppm/K ²	
Frequency inversion temperature		40	°C	
Operating temperature range				- 40 °C ... + 85 °C
Storage temperature range				- 45 °C ... + 90 °C

*) The terminating impedances depend on parasitics and q-values of matching elements and the board used, and are to be understood as reference values only. Should there be additional questions do not hesitate to ask for an application note or contact our design team.

**) $\Delta f_c(\text{Hz}) = TC_f(\text{ppm/K}^2) \times (T - T_A)^2 \times f_{CAT}(\text{MHz})$

Generated:

Checked / Approved:

Vectron International GmbH
Potsdamer Straße 18
D 14 513 TELTOW / Germany
Tel: (+49) 3328 4784-0 / Fax: (+49) 3328 4784-30
E-Mail: tft@vectron.com

Vectron International GmbH reserves the right to make changes to the product(s) and/or information contained herein without notice. No liability is assumed as a result of their use or application. No rights under any patent accompany the sale of any such product(s) or information.

Filter characteristic

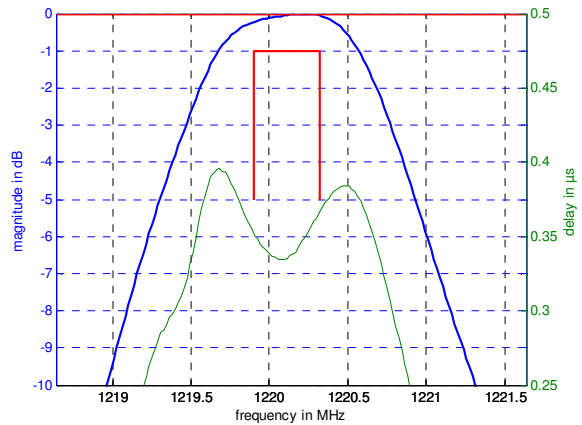
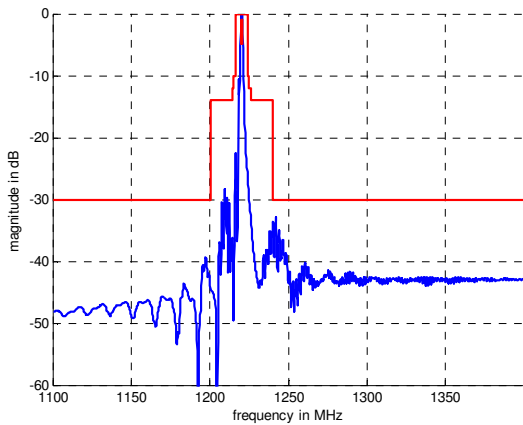

Construction and pin connection

(All dimensions in mm)

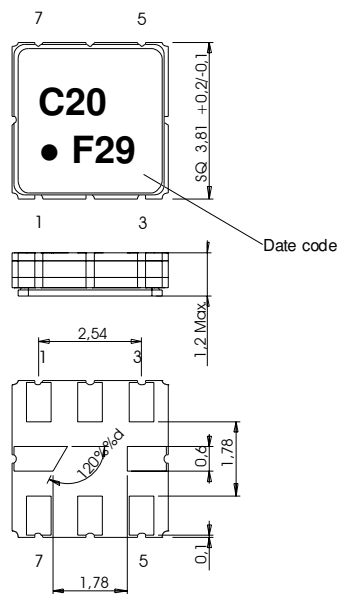

1	Ground
2	Input
3	Ground
4	Ground
5	Ground
6	Output
7	Ground
8	Ground

Date code: Year + week

F	2015
G	2016
H	2017
...	

50 Ohm Test circuit

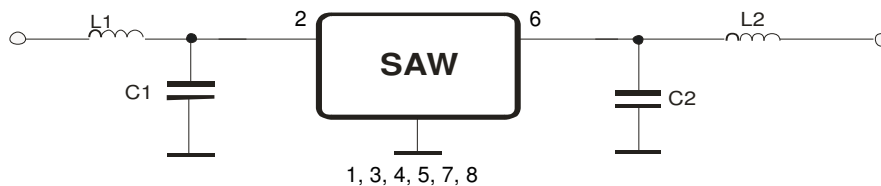

Vectron International GmbH
 Potsdamer Straße 18
 D 14 513 TELTOW / Germany
 Tel: (+49) 3328 4784-0 / Fax: (+49) 3328 4784-30
 E-Mail: tft@vectron.com

Vectron International GmbH reserves the right to make changes to the product(s) and/or information contained herein without notice. No liability is assumed as a result of their use or application. No rights under any patent accompany the sale of any such product(s) or information.

Stability characteristics, reliability

After the following tests the filter shall meet the whole specification:

- 1. Shock: 500g, 1ms, half sine wave, 3 shocks each plane;
DIN IEC 68 T2 - 27
- 2. Vibration: 10Hz to 500Hz, 0.3mm or 5g respectively, 1 octave per min, 10 cycles per plane, 3 planes; DIN IEC 68 T2 - 6
- 3. Change of temperature: -5 °C to 125°C / 15 min. each / 100 cycles
DIN IEC 6 part 2 – 14 Test N
- 4. Resistance to solder heat (reflow): reflow possible: three times max.;
for temperature conditions, see page 4: "Air reflow temperature conditions"

This filter is RoHS compliant (2011/65/EU)

Packing

Tape & Reel: IEC 286 – 3, with exception of value for N and minimum bending radius;
tape type II, embossed carrier tape with top cover tape on the upper side;

max. pieces of filters per reel:	3000
reel of empty components at start:	min. 300 mm
reel of empty components at start including leader:	min. 500 mm
trailer:	min. 300 mm

Tape (all dimensions in mm)

- W : 12.00 ± 0.3
- Po : 4.00 ± 0.1
- Do : 1.50 +0.1/-0
- E : 1.75 ± 0.1
- F : 5.50 ± 0.05
- G(min) : 0.75
- P2 : 2.00 ± 0.05
- P1 : 8.00 ± 0.1
- D1(min) : 1.50
- Ao : 4.30 ± 0.1
- Bo : 4.30 ± 0.1
- Ct : 9.2 ± 0.1

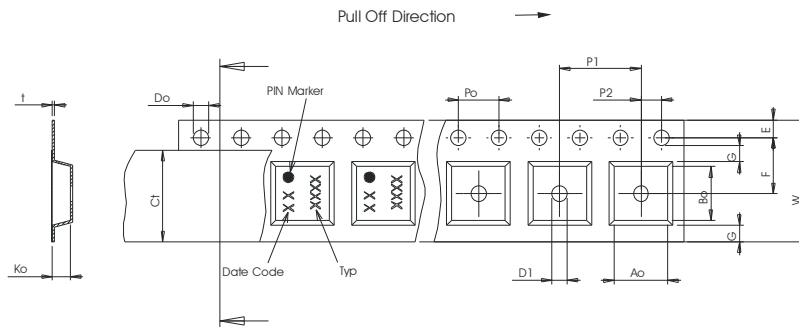

Reel (all dimensions in mm)

- A : 330 or 180
- W1 : 12.4 +2/-0
- W2(max) : 18.4
- N(min) : 50
- C : 13.0 +0.5/-0.2

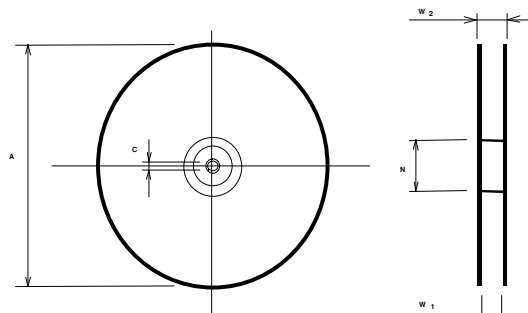

The minimum bending radius is 45 mm.

Vectron International GmbH
Potsdamer Straße 18
D 14 513 TELTOW / Germany
Tel: (+49) 3328 4784-0 / Fax: (+49) 3328 4784-30
E-Mail: tft@vectron.com

Vectron International GmbH reserves the right to make changes to the product(s) and/or information contained herein without notice. No liability is assumed as a result of their use or application. No rights under any patent accompany the sale of any such product(s) or information.

Air reflow temperature conditions

Conditions	Exposure
Average ramp-up rate (30°C to 217°C)	less than 3°C/second
> 100°C	between 300 and 600 seconds
> 150°C	between 240 and 500 seconds
> 217°C	between 30 and 150 seconds
Peak temperature	max. 260°C
Time within 5°C of actual peak temperature	between 10 and 30 seconds
Cool-down rate (Peak to 50°C)	less than 6°C/second
Time from 30°C to Peak temperature	no greater than 300 seconds

Chip-mount air reflow profile

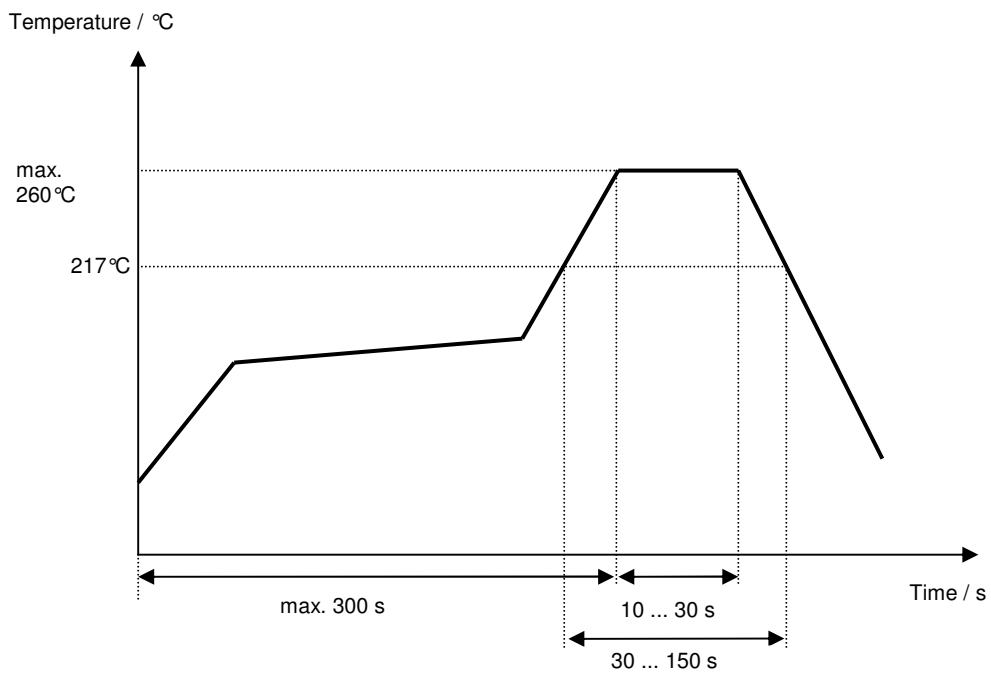

Vectron International GmbH
 Potsdamer Straße 18
 D 14 513 TELTOW / Germany
 Tel: (+49) 3328 4784-0 / Fax: (+49) 3328 4784-30
 E-Mail: tft@vectron.com

Vectron International GmbH reserves the right to make changes to the product(s) and/or information contained herein without notice. No liability is assumed as a result of their use or application. No rights under any patent accompany the sale of any such product(s) or information.

History

Version	Reason of Changes	Name	Date
1.0	- Generation of development specification according to customer specification	Dr. Sabah	26.03.2002
1.1	- Changing range of storage temperature - Reducing maximum of insertion loss to 4 dB - Changing relativ attenuation	Pfeiffer	05.04.2002
1.2	- Change insertion loss and relative attenuation	Dr. Sabah	18.07.2002
1.3	- Preliminary Specification; add of typical values and terminating impedance	Dr. Sabah	19.08.2002
1.4	- Filter Specification; add of terminating impedance and frequency inversion temperature	Dr. Sabah	21.08.2002
1.5	- Changing of pin configuration: input and outout pin	Dr. Sabah	13.01.2003
1.6	- add filter characteristic	Noack	05.10.2006
1.7	- Correcting typo (terminating impedance)	S.Springfeldt	12.11.2014
2.0	- Change of tape and reel orientation	S.Springfeldt	14.07.2015

Vectron International GmbH
Potsdamer Straße 18
D 14 513 TELTOW / Germany
Tel: (+49) 3328 4784-0 / Fax: (+49) 3328 4784-30
E-Mail: tft@vectron.com

Vectron International GmbH reserves the right to make changes to the product(s) and/or information contained herein without notice. No liability is assumed as a result of their use or application. No rights under any patent accompany the sale of any such product(s) or information.