

---

### Standard Read/Write ID Transponder with Anti-collision

---

#### DATASHEET

---

#### Features

- Read/write anti-collision ID transponder in plastic package
- Contactless read/write data transmission
- Inductive coupled power supply at 125kHz
- Basic component: R/W IDIC® e5551
- Anti-collision mode by password request
  - E.g. 10 transponders read out in < 500ms (RF/32, Maxblock 2) depending on the application
- Built-in coil and capacitor for circuit antenna
- Starts with cyclical data read out
- 224-bit EEPROM user programmable in 32-bit blocks
- Typically < 50ms to write and verify a block
- Write protection by block bits
- Malprogramming protection
- Options set by EEPROM
  - Bit rate [bit/s]: RF/8, RF/16, RF/32, RF/40, RF/50, RF/64, RF/100, RF/128
  - Modulation: BIN, FSK, PSK, Manchester, bi-phase

---

#### Application

- Access control systems
- Process control and automation systems
- Installation and medical equipment
- Asset management systems

## 1. Description

The Atmel® TK5551 is a completely programmable R/W transponder which implements all important functions for identification systems, including anti-collision (e.g., 10 transponders in < 500ms depending on the application). It allows the contactless reading and writing of data which are transmitted bi-directionally between a read/write base station and the transponder. It is a plastic-packaged device which accommodates the IDIC e5551 and also the antenna realized as an LC-circuit. No additional external power supply is necessary for the transponder because it receives power from the RF field generated by the base station. Data are transmitted by modulating the amplitude of the RF field. The Atmel TK5551 can be used to adjust and modify the ID code or any other stored data, e.g., rolling code systems. The on-chip 264-bit EEPROM (8 blocks, 33 bits per block) can be read and written block wise from the base station. The blocks can be protected against overwriting. One block is reserved for setting the operation modes of the IC. Another block can obtain a password to prevent unauthorized writing.

Figure 1-1. System Block Diagram

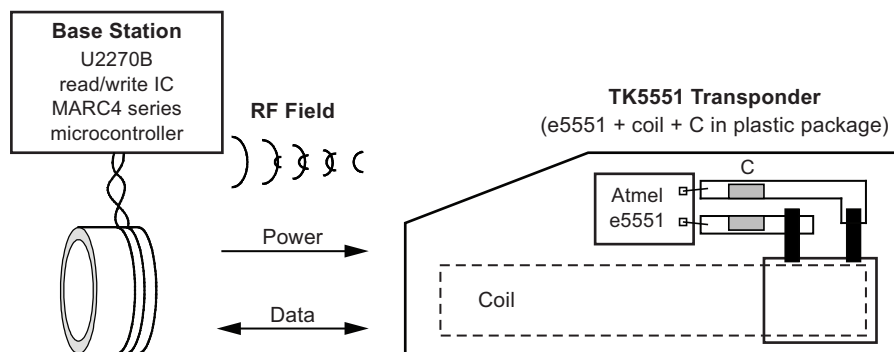

## 2. General

The transponder is the mobile part of the closed coupled identification system (see [Figure 1-1](#)), whereas the read/write base station is based on the Atmel U2270B or on discrete solutions, and the read/write transponder is based on the IDIC e5551.

The transponder is a plastic cube device consisting of the following parts:

- The transponder antenna, realized as a tuned LC circuit
- Read/write IDIC (e5551) with EEPROM

## 3. Transponder Antenna

The antenna consists of a coil and a capacitor for tuning the circuit to the nominal carrier frequency of 125kHz. The coil has a ferrite core for improving the distance of read, write and programming operations.

## 4. Read/Write IDIC e5551

The read/write IDIC e5551 is part of the Atmel® transponder TK5551. The data are transmitted bi-directionally between the base station and the transponder. The transponder receives power via a single coil from the RF signal generated by the base station. The single coil is connected to the chip and also serves as the IC's bi-directional communication interface.

Data are transmitted by modulating the amplitude of the RF signal. Reading of register contents occurs by damping the coil by an internal load. Writing into registers occurs by interrupting the RF field in a specific way. The Atmel TK5551 transponder operates at a nominal frequency of 125kHz. There are different bit rates and encoding schemes.

The on-chip 264-bit EEPROM (8 block, 33 bits each) can be read and written block wise from the base station. The blocks can be protected against overwriting by using lock bits. One block is reserved for setting the operation modes of the IC. Another block contains a password to prevent unauthorized writing.

See e5551 data sheet for more detailed information of the IDIC.

Figure 4-1. Block Diagram of the e5551

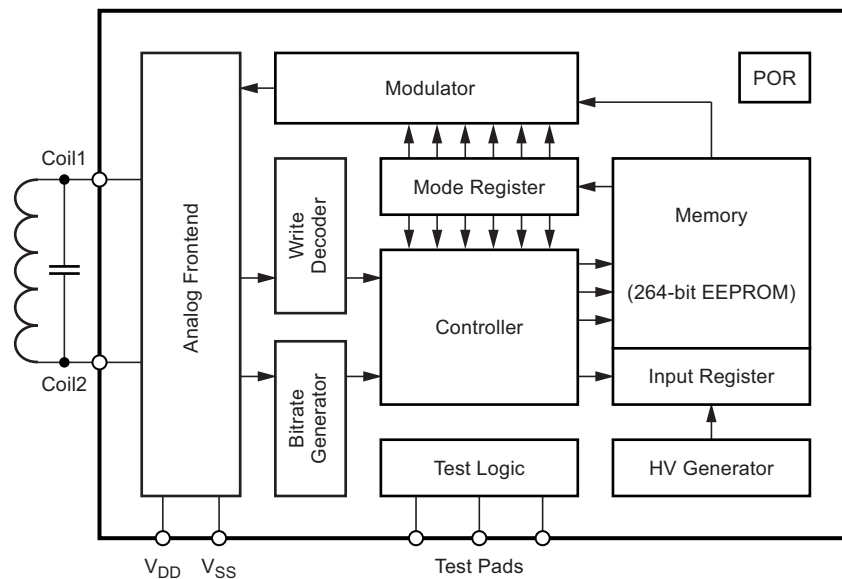

## 5. Absolute Maximum Ratings

Stresses beyond those listed under “Absolute Maximum Ratings” may cause permanent damage to the device. This is a stress rating only and functional operation of the device at these or any other conditions beyond those indicated in the operational sections of this specification is not implied. Exposure to absolute maximum rating conditions for extended periods may affect device reliability

Parameters	Symbol	Value	Unit
Operating temperature range	$T_{amb}$	-40 to +85	°C
Storage temperature range	$T_{stg}$	-40 to +125	°C
Assembly temperature $t < 5$ minutes	$T_{ass}$	170	°C
Magnetic field strength at 125 kHz	$H_{pp}$	1000	A/m

## 6. Operating Characteristics: Transponder

$T_{amb} = 25^{\circ}\text{C}$ ,  $f = 125$  kHz, unless otherwise specified

Parameters	Test Conditions	Symbol	Min.	Typ.	Max.	Unit
Inductance		L		3.8		mH
<b>LC Circuit, <math>H_{pp} = 20</math> A/m</b>						
Resonance frequency	Room temperature	$f_r$	120	125	130	kHz
Quality factor		$Q_{LC}$		13		
<b>Magnetic Field Strength (H)</b>						
Maximum field strength where tag does not modulate	No influence to other tags in the field	$H_{pp\ not}$		4		A/m
Field strength for operation	$T_{amb} = -40^{\circ}\text{C}$	$H_{pp\ -40}$		30		A/m
	$T_{amb} = 25^{\circ}\text{C}$	$H_{pp\ 25}$		18		A/m
	$T_{amb} = 85^{\circ}\text{C}$	$H_{pp\ 85}$		17		A/m
Programming mode	$T_{amb} = 25^{\circ}\text{C}$	$H_{pp}$		50		A/m
Data retention EEPROM	$T_{amb} = 25^{\circ}\text{C}$	$t_{retention}$	10			Years
Programming cycles EEPROM			100,000			
Programming time/block	RF = 125 kHz	$t_p$		16		ms
Maximum field strength		$H_{pp\ max}$			600	A/m
<b>Modulation Range (see also H-DV Curve)</b>						
Modulation range	$H_{pp} = 20\text{A/m}$ $H_{pp} = 30\text{A/m}$ $H_{pp} = 50\text{A/m}$ $H_{pp} = 100\text{A/m}$	DV		4.0 6.0 8.0 8.0		V

Figure 6-1. Typical  $T_K$  Range of Resonance Frequency

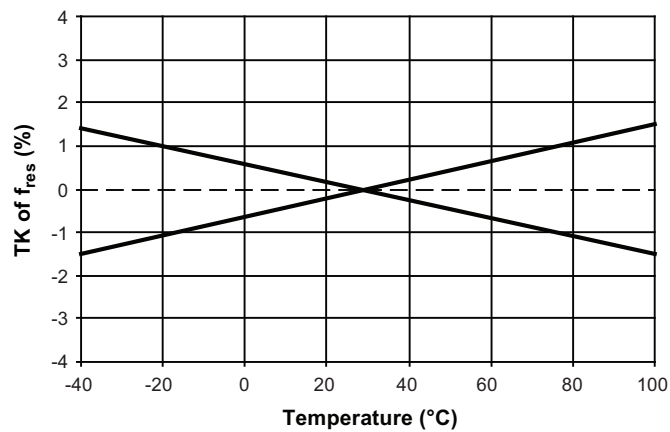

Figure 6-2. Typical H-DV Curve

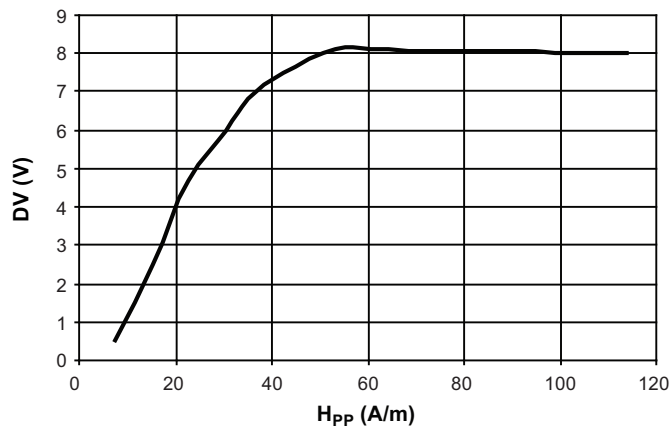
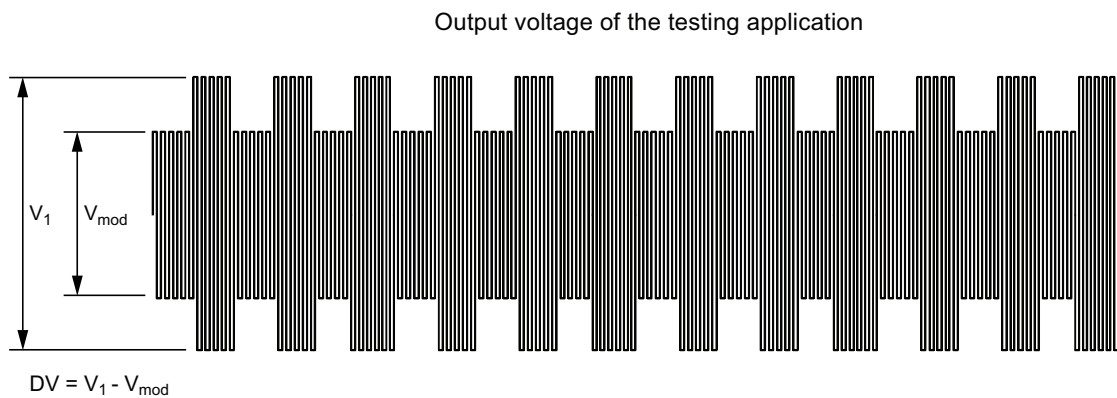

Figure 6-3. Measurement of the Modulation Range DV



## 7. Measurement Assembly

All parameters are measured in a Helmholtz arrangement, which generates a homogenous magnetic field (see [Figure 7-1](#) and [Figure 7-2](#)). A function generator drives the field generating coils, so the magnetic field can be varied in frequency and field strength.

**Figure 7-1. Testing Application**

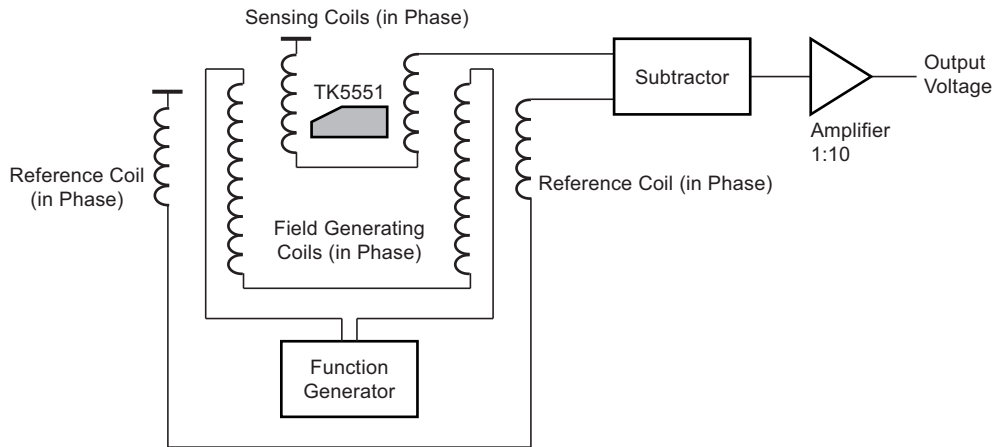

**Figure 7-2. Testing Geometry**

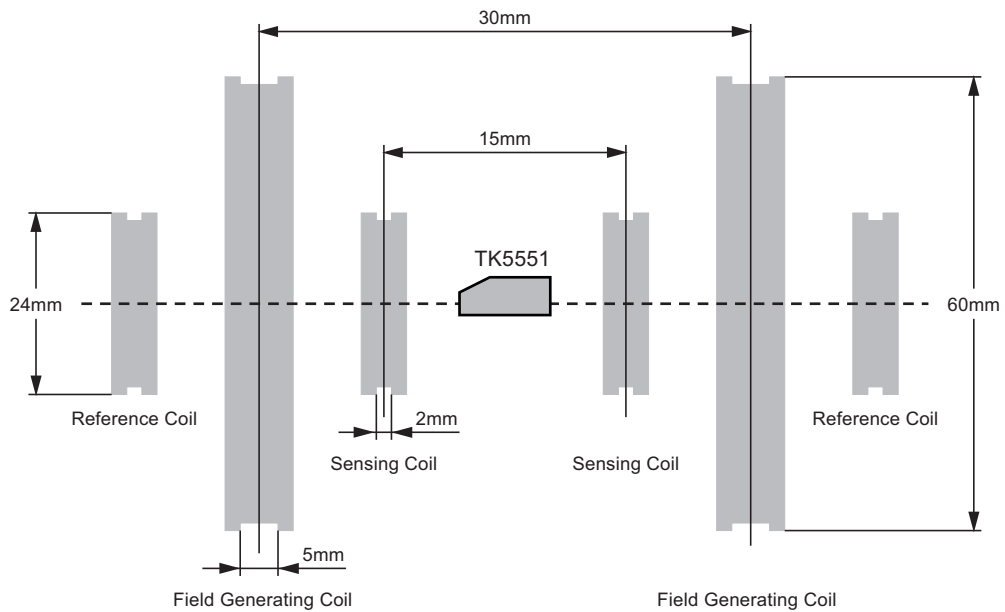

## 8. Writing Data into the TK5551

The write sequence of the Atmel® TK5551 is shown below. Writing data into the transponder occurs by interrupting the RF field with short gaps. After the start gap the standard write OP code (10) is followed by the lock bit. The next 32 bits contain the actual data. The last 3 bits denote the destination block address. If the correct number of bits have been received, the actual data is programmed into the specified memory block.

**Figure 8-1. Write Protocol**

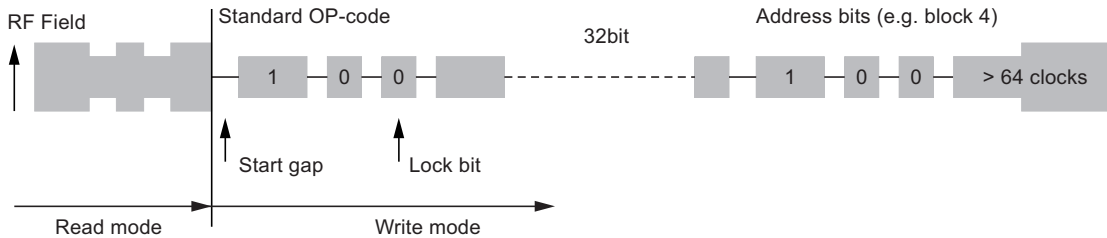

## 9. Write Data Decoding

The time elapsing between two detected gaps is used to encode the information. As soon as a gap is detected, a counter starts counting the number of field clock cycles until the next gap is detected. Depending on how many field clocks elapse, the data is regarded as "0" or "1". The required number of field clocks is shown in Figure 9-1. A valid "0" is assumed if the number of counted clock periods is between 16 and 32, for a valid "1" it is 48 or 64 respectively. Any other value being detected results in an error, and the device exits write mode and returns to read mode.

**Figure 9-1. Write Data Decoding Scheme**

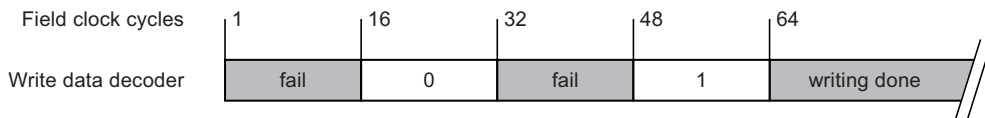

## 10. Actual Behavior of the Device

The Atmel® TK5551 detects a gap if the voltage across the coils decreases below the threshold value of an internal MOS transistor. Until then, the clock pulses are counted. The number given for a valid “0” or “1” (see Figure 9-1 on page 7) refers to the actual clock pulses counted by the device. However, there are always more clock pulses being counted than were applied by the base station. The reason for this is the fact that an RF field cannot be switched off immediately. The coil voltage decreases exponentially. So although the RF field coming from the base station is switched off, it takes some time until the voltage across the coils reaches the threshold value of an internal MOS transistor and the device detects the gap.

Referring to the following diagram (see Figure 10-1), this means that the device uses the times  $t_{0\text{ internal}}$  and  $t_{1\text{ internal}}$ . The exact times for  $t_0$  and  $t_1$  are dependent on the application (e.g., field strength, etc.)

Measured write-time frames of the IDIC demo kit software are:

$$\begin{aligned} t_0 &= 50\mu\text{s to } 130\mu\text{s} \\ t_1 &= 270\mu\text{s to } 390\mu\text{s} \\ t_{\text{gap}} &= 180\mu\text{s to } 400\mu\text{s} \end{aligned}$$

Antennas with a high Q-factor require longer times for  $t_{\text{gap}}$  and shorter time values for  $t_0$  and  $t_1$ .

**Figure 10-1. Ideal and Real Behavior Signals**

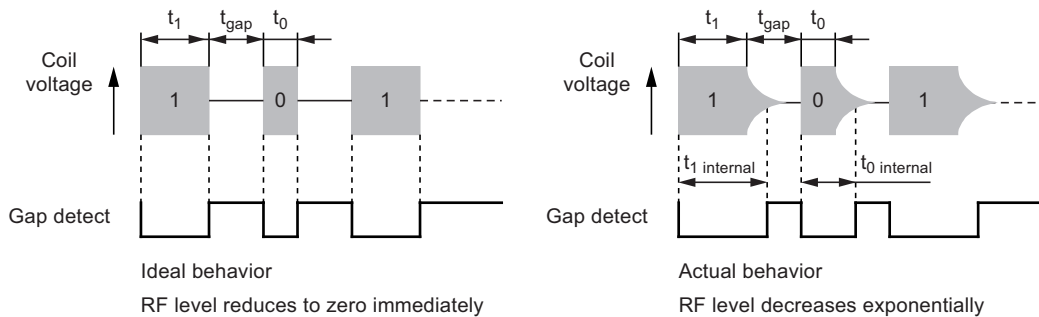

## 11. Operating Distance

The maximum distance between the base station and the Atmel TK5551 depends mainly on the base station, the coil geometries and the modulation options chosen (see “U2270B Antenna Design Hints” and the “U2270B” data sheet). Under laboratory conditions, a distance of up to 9cm can be reached. For optimized distance, please refer to the application note. When using Atmel’s U2270B demo board, the typical distances in the range of 0cm to 5cm can be achieved.

### 11.1 Anti-collision Mode by Password Request (AOR = Answer-On-Request)

The AOR mode is an anti-collision procedure for transponders to read, e.g., 10 transponders in the field during 500ms (RF/32, maxblock 2). The number of transponders and the time to read out are dependent on the application.

If the AOR mode has been configured by AOR bit at block 0, the transponder remains in sleep mode while putting it into the field. If the specified AOR wake-up command is sent, the dedicated transponder generates an internal RESET (see section “OP Code Formats” in the e5551 data sheet). Due to the RESET the transponder is woken up. That means, the transponder is able to modulate the field (read mode). The AOR wake-up command consists of the OP code and the 32-bit password. The time duration to send the AOR wake-up sequence is between 8.7ms and 27.5ms according to Figure 10-1. The time duration is dependent on the minimum/maximum values of the measured write-time frames and the content of the password. To select another transponder in the field, it is necessary to send the stop OP code to stop the modulation of the transponder.





### 13. Ordering Information

Extended Type Number	Package	Remarks
TK5551M-PP	Plastic package	All kinds of modulation; RF/8, RF/16, RF/32, RF/40, RF/50,RF/64,RF/100 and RF/128 <sup>(1)</sup> . Default programmed: Manchester modulation, RF/32, MAXBLK = 2

Note: 1. See datasheet e5551

### 14. Package Information

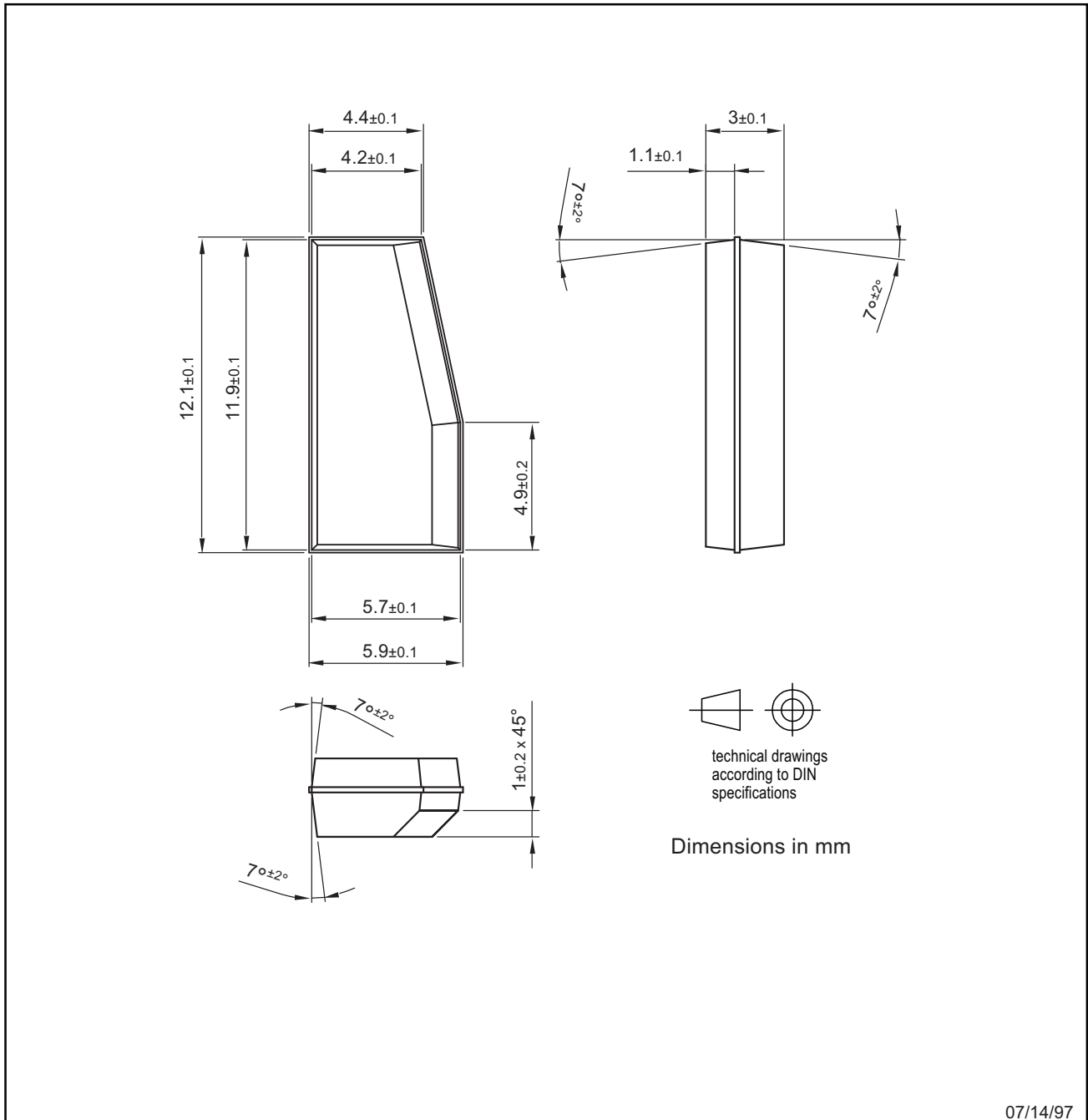

07/14/97

<b>Package Drawing Contact:</b> packagedrawings@atmel.com	<b>TITLE</b> Package: Transponder	<b>GPC</b>	<b>DRAWING NO.</b> 6.549-5030.01-4	<b>REV.</b>
				1

## 15. Revision History

Please note that the following page numbers referred to in this section refer to the specific revision mentioned, not to this document.

Revision No.	History
4709H-RFID-04/14	<ul style="list-style-type: none"><li>• Put datasheet in the latest template</li></ul>
4709G-RFID-07/10	<ul style="list-style-type: none"><li>• Unit of times <math>t_0</math>, <math>t_1</math> and <math>t_{gap}</math> from ms to <math>\mu</math>s on page 8 changed</li></ul>
4709F-RFID-06/06	<ul style="list-style-type: none"><li>• Put datasheet in a new template</li><li>• Pb-free logo on page 1 deleted</li></ul>
4709E-RFID-12/05	<ul style="list-style-type: none"><li>• Last page: Legal sentence changed</li></ul>
4709D-RFID-10/05	<ul style="list-style-type: none"><li>• Figure12-1 “Complete Transponder System with the Read/Write Base Station IC U2270B” on page 9 changed</li></ul>
4709C-RFID-06/05	<ul style="list-style-type: none"><li>• Put datasheet in a new template</li><li>• Lead-free Logo on page 1 added</li></ul>



**Atmel Corporation** 1600 Technology Drive, San Jose, CA 95110 USA T: (+1)(408) 441.0311 F: (+1)(408) 436.4200 | [www.atmel.com](http://www.atmel.com)

© 2014 Atmel Corporation. / Rev.: Rev.: 4709H–RFID–04/14

Atmel®, Atmel logo and combinations thereof, Enabling Unlimited Possibilities®, IDIC®, and others are registered trademarks or trademarks of Atmel Corporation or its subsidiaries. Other terms and product names may be trademarks of others.

DISCLAIMER: The information in this document is provided in connection with Atmel products. No license, express or implied, by estoppel or otherwise, to any intellectual property right is granted by this document or in connection with the sale of Atmel products. EXCEPT AS SET FORTH IN THE ATMEL TERMS AND CONDITIONS OF SALES LOCATED ON THE ATMEL WEBSITE, ATMEL ASSUMES NO LIABILITY WHATSOEVER AND DISCLAIMS ANY EXPRESS, IMPLIED OR STATUTORY WARRANTY RELATING TO ITS PRODUCTS INCLUDING, BUT NOT LIMITED TO, THE IMPLIED WARRANTY OF MERCHANTABILITY, FITNESS FOR A PARTICULAR PURPOSE, OR NON-INFRINGEMENT. IN NO EVENT SHALL ATMEL BE LIABLE FOR ANY DIRECT, INDIRECT, CONSEQUENTIAL, PUNITIVE, SPECIAL OR INCIDENTAL DAMAGES (INCLUDING, WITHOUT LIMITATION, DAMAGES FOR LOSS AND PROFITS, BUSINESS INTERRUPTION, OR LOSS OF INFORMATION) ARISING OUT OF THE USE OR INABILITY TO USE THIS DOCUMENT, EVEN IF ATMEL HAS BEEN ADVISED OF THE POSSIBILITY OF SUCH DAMAGES. Atmel makes no representations or warranties with respect to the accuracy or completeness of the contents of this document and reserves the right to make changes to specifications and products descriptions at any time without notice. Atmel does not make any commitment to update the information contained herein. Unless specifically provided otherwise, Atmel products are not suitable for, and shall not be used in, automotive applications. Atmel products are not intended, authorized, or warranted for use as components in applications intended to support or sustain life.

SAFETY-CRITICAL, MILITARY, AND AUTOMOTIVE APPLICATIONS DISCLAIMER: Atmel products are not designed for and will not be used in connection with any applications where the failure of such products would reasonably be expected to result in significant personal injury or death ("Safety-Critical Applications") without an Atmel officer's specific written consent. Safety-Critical Applications include, without limitation, life support devices and systems, equipment or systems for the operation of nuclear facilities and weapons systems. Atmel products are not designed nor intended for use in military or aerospace applications or environments unless specifically designated by Atmel as military-grade. Atmel products are not designed nor intended for use in automotive applications unless specifically designated by Atmel as automotive-grade.