



**8-INPUT PECL
DIFFERENTIAL MUX
WITH TTL SELECTS**

SY100S863

FEATURES

- Low skew
- Differential PECL inputs
- Differential cut-off PECL outputs capable of driving 25Ω load for driving data bus
- Tri-state TTL output
- TTL select and enable input
- Internal 75KΩ PECL input pull-down resistors
- PECL I/O fully compatible with industry standard
- Available in 28-pin PLCC package

DESCRIPTION

The SY100S863 is a PECL 8:1 multiplexer designed for use in new, high-performance PECL systems. It has differential PECL outputs and a standard TTL output. The TTL select inputs (SEL₀, SEL₁, SEL₂) determine which one of the eight differential PECL data inputs (D₀–D₇) is propagated to the outputs. The enable pin, EN, is provided for expansion. When EN is at a TTL logic one level, both PECL and TTL outputs are enabled. When the enable pin is set to TTL logic zero level, both PECL outputs of the differential pair are in cut-off and the TTL output is in a three-state condition.

BLOCK DIAGRAM

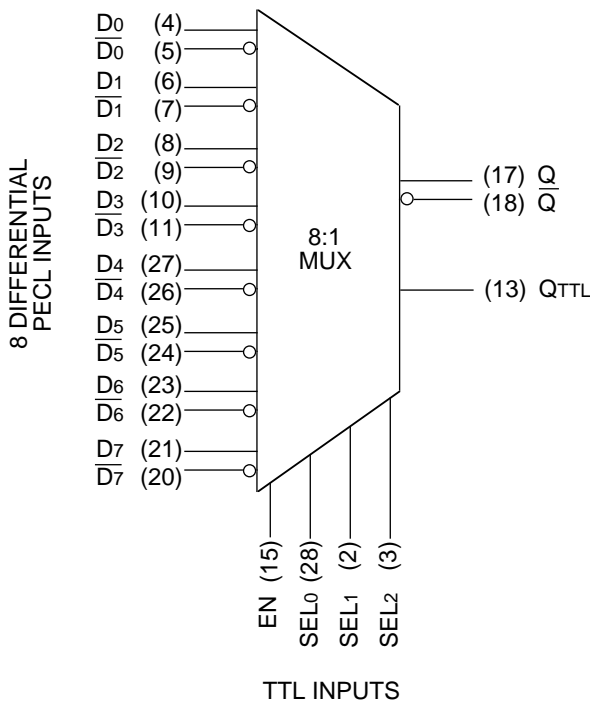

PIN NAMES

Pin	Function
D ₀ , /D ₀ – D ₇ , /D ₇	Differential PECL Input Pairs
Q, /Q	Differential PECL Outputs
QTTL	TTL Output
EN	Enable Input
SEL _{0,1,2}	Select Inputs

PACKAGE/ORDERING INFORMATION

Ordering Information

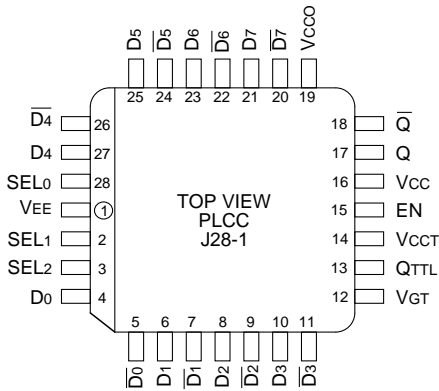

28-Pin PLCC (J28-1)

Part Number	Package Type	Operating Range	Package Marking	Lead Finish
SY100S863JC	J28-1	Commercial	SY100S863JC	Sn-Pb
SY100S863JCTR ⁽¹⁾	J28-1	Commercial	SY100S863JC	Sn-Pb
SY100S863JZ ⁽²⁾	J28-1	Commercial	SY100S863JZ with Pb-Free bar-line indicator	Matte-Sn
SY100S863JZTR ^(1, 2)	J28-1	Commercial	SY100S863JZ with Pb-Free bar-line indicator	Matte-Sn

Notes:

1. Tape and Reel.
2. Pb-Free package is recommended for new designs.

TRUTH TABLE

EN	SEL ₂	SEL ₁	SEL ₀	Q	QTTL
H	L	L	L	D ₀	D ₀
H	L	L	H	D ₁	D ₁
H	L	H	L	D ₂	D ₂
H	L	H	H	D ₃	D ₃
H	H	L	L	D ₄	D ₄
H	H	L	H	D ₅	D ₅
H	H	H	L	D ₆	D ₆
H	H	H	H	D ₇	D ₇
L	X	X	X	Z	Z

PECL DC ELECTRICAL CHARACTERISTICS

V_{CC} = V_{CCO} = V_{CCCT} = 5.0V ± 5%; V_{EE} = V_GT = GND

Symbol	Parameter	Min.	Typ.	Max.	Unit	Condition
V _{OH}	Output HIGH Voltage ⁽¹⁾	3.975	4.045	4.13	V	Loading with 25Ω to 3V (V _{CC} -2V)
V _{OL}	Output LOW Voltage ⁽¹⁾	3.17	3.295	3.38	V	Loading with 25Ω to 3V (V _{CC} -2V)
V _{0Z}	Cutoff Voltage ⁽¹⁾	—	3	3.10	V	Loading with 25Ω to 3V (V _{CC} -2V)
V _{IH}	Input HIGH Voltage	3.835	—	4.13	V	
V _{IL}	Input LOW Voltage	3.17	—	3.525	V	
I _{IH}	Input HIGH Current	—	—	350	μA	V _{IN} = V _{IH} (Max.)
I _{IL}	Input LOW Current	0.50	—	—	μA	V _{IN} = V _{IL} (Min.)
I _{CC}	V _{CC} Supply Current	—	73	88	mA	

Note:

1. Levels shown are for V_{CCO} = 5.0V and will vary 1:1 with powers.

TTL DC ELECTRICAL CHARACTERISTICS

V_{CC} = V_{CCO} = V_{CCCT} = 5.0V ± 5%; V_{EE} = V_GT = GND

Symbol	Parameter	Min.	Typ.	Max.	Unit	Condition
V _{OH}	Output HIGH Voltage	2.4	2.9	—	V	I _{OH} = -3mA
V _{OL}	Output LOW Voltage	—	0.3	0.5	V	I _{OL} = 24mA
V _{IH}	Input HIGH Voltage	2.0	—	V _{CC}	V	
V _{IL}	Input LOW Voltage	0	—	0.8	V	
I _{IH}	Input HIGH Current	—	—	1.0	mA	V _{IN} = 2.7V
I _{IL}	Input LOW Current	-0.7	—	—	mA	V _{IN} = 0.5V
V _{IK}	Input Clamp Voltage	-1.2	—	—	V	I _{IN} = -18mA
I _{OS}	Output Short Circuit Current	-200	—	-60	mA	V _{OUT} = 0V, V _{CCCT} = 5.5V
I _{OZHT}	Tri-state Current Output HIGH	—	—	70	μA	V _{OUT} = 2.7V
I _{OZLT}	Tri-state Current Output LOW	-700	—	—	μA	V _{OUT} = 0.5V

PECL AC ELECTRICAL CHARACTERISTICS

VCC = VCCO = +5.0V ± 5%; VEE = VGT = GND

Symbol	Parameter	TA = 0°C			TA = +25°C			TA = +85°C			Unit	Condition
		Min.	Typ.	Max.	Min.	Typ.	Max.	Min.	Typ.	Max.		
tPLH tPHL	Propagation Delay ^{(1),(2)} D to Q SEL0 to Q SEL1 to Q SEL2 to Q	500	—	900	500	—	900	500	—	900	ps	
tPZH tPHZ	EN to Q ⁽³⁾ (Cutoff to HIGH) EN to Q ⁽³⁾ 300 (HIGH to Cutoff)	300	—	1750	300	—	1750	300	—	1750	ps	
tr tf	Output Rise/Fall Times ⁽²⁾ 20% to 80%	300	400	600	300	400	600	300	400	600	ps	

Notes:

1. Part-to-part skew is defined as Max. – Min. value at the given temperature.
2. RL = 50Ω
3. Figures 1 and 2

TTL AC ELECTRICAL CHARACTERISTICS

VCC = VCCO = 5V ± 5%; VEE = VGT = GND

Symbol	Parameter	TA = 0°C			TA = +25°C			TA = +85°C			Unit	Condition
		Min.	Typ.	Max.	Min.	Typ.	Max.	Min.	Typ.	Max.		
tPLH tPHL	Propagation Delay ^{(1),(2)} D to QTTL SEL0 to QTTL SEL1 to QTTL SEL2 to QTTL	2.5	—	5.0	2.5	—	5.0	2.5	—	5.0	ns	
tPZH tPZL	EN to TTL Output ⁽²⁾ (Enable Time)	2.5	—	5.0	2.5	—	5.0	2.5	—	5.0	ns	
tPHZ tPLZ	EN to TTL Output ⁽²⁾ (Disable Time)	2.5	—	5.0	2.5	—	5.0	2.5	—	5.0	ns	
tr tf	Output Rise/Fall Time ⁽³⁾ 0.8V to 2.4V 0.8V to 2.0V	0.3	—	1.6	0.3	—	1.6	0.3	—	1.6	ns	

Notes:

1. Part-to-part skew is defined as Max. – Min. value at the given temperature.
2. Figures 3 and 4
3. CL = 25pF

PECL-TO-PECL TEST CIRCUITRY

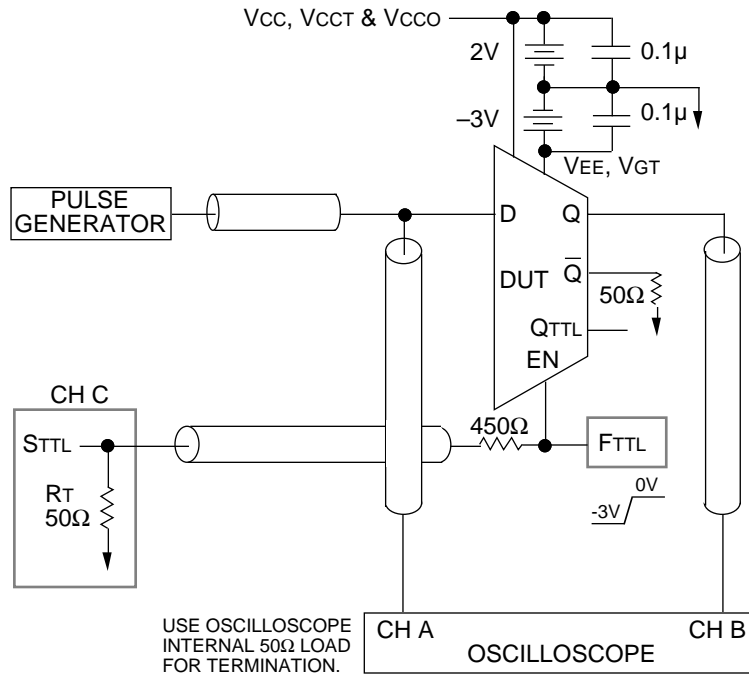

Figure 1. PECL-to-PECL AC Test Circuit

PECL-TO-PECL SWITCHING WAVEFORMS

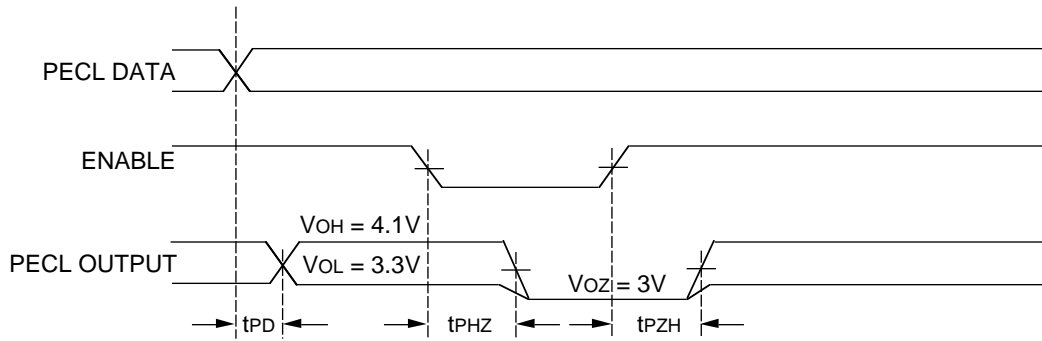

Figure 2. PECL-to-PECL Transition — Propagation Delay and Transition Times

PECL-TO-TTL TEST CIRCUITRY

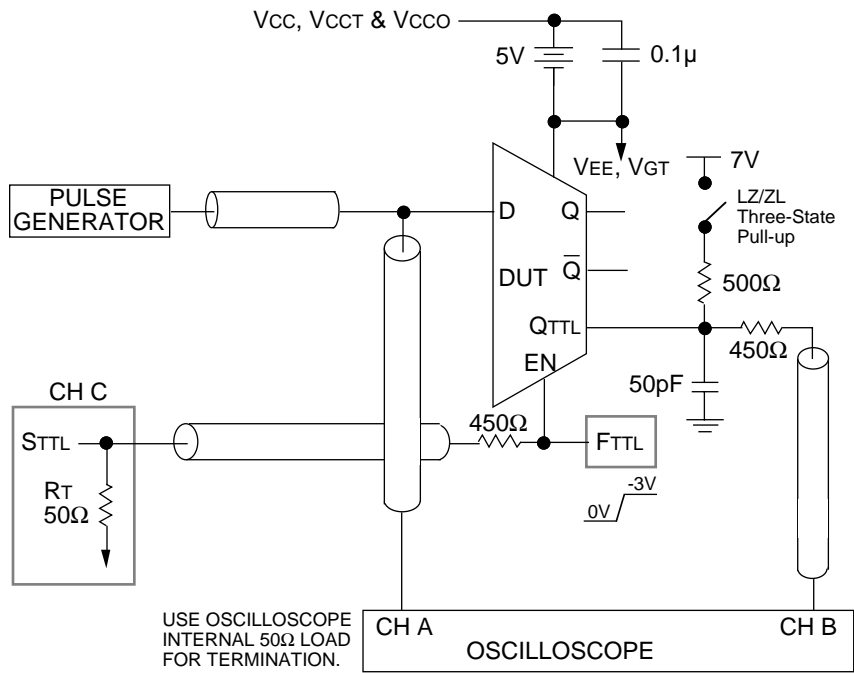

Figure 3. PECL-to-TTL AC Test Circuit

PECL-TO-TTL SWITCHING WAVEFORMS

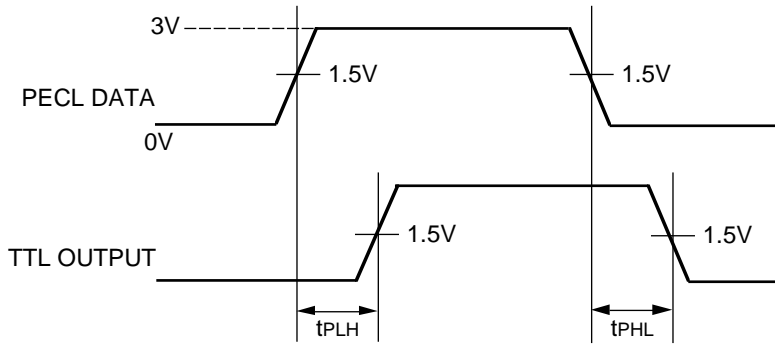

Figure 4a. PECL-to-TTL Transition, Data to TTL Output Delay

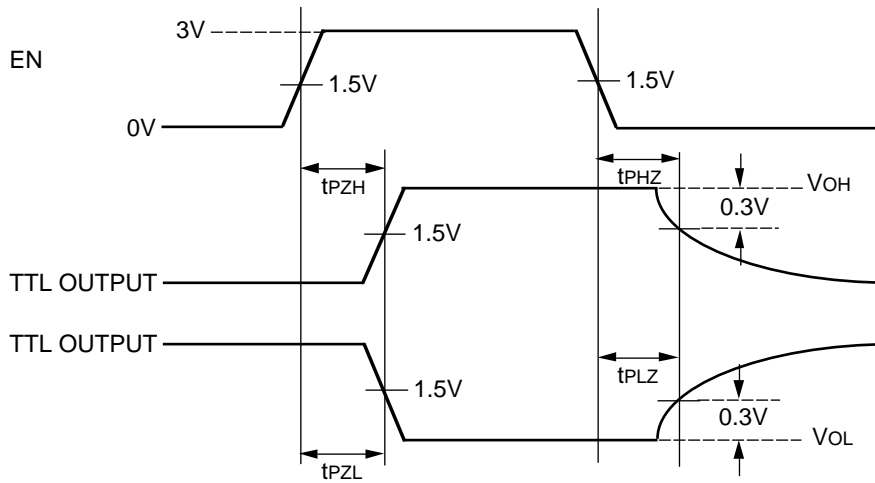
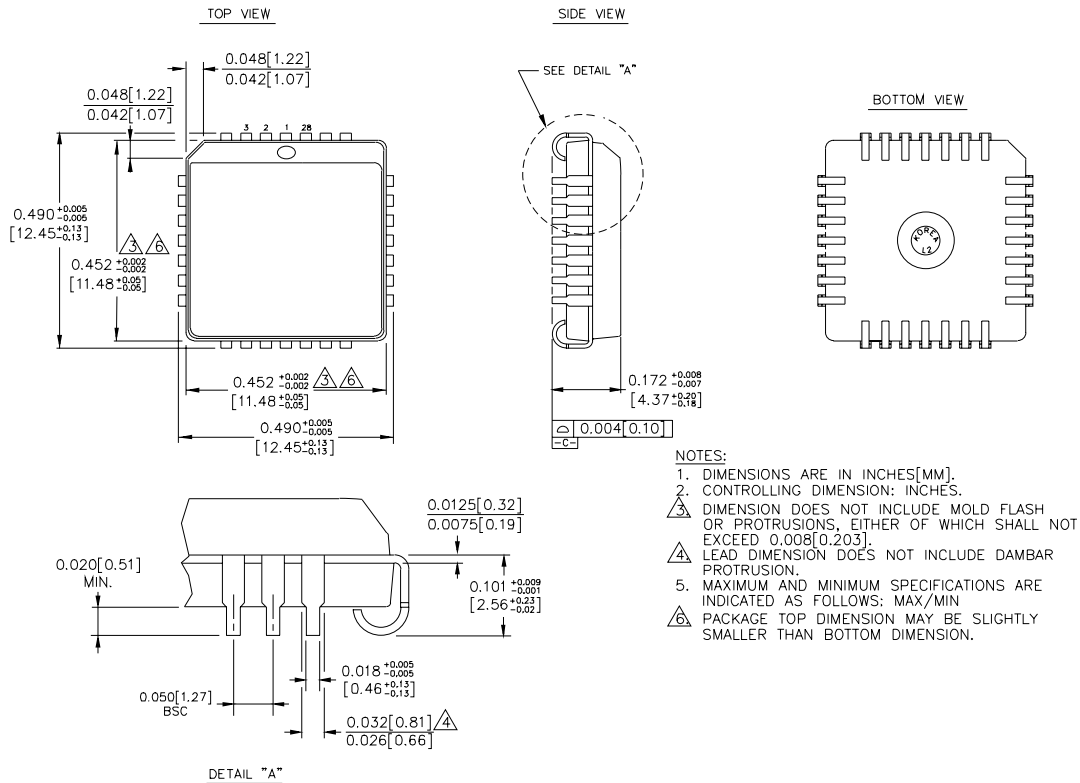

Figure 4b. EN to TTL Output Enable and Disable Times

28-PIN PLCC (J28-1)



Rev. 03

MICREL, INC. 2180 FORTUNE DRIVE SAN JOSE, CA 95131 USA

TEL + 1 (408) 944-0800 FAX + 1 (408) 474-1000 WEB <http://www.micrel.com>

The information furnished by Micrel in this datasheet is believed to be accurate and reliable. However, no responsibility is assumed by Micrel for its use. Micrel reserves the right to change circuitry and specifications at any time without notification to the customer.

Micrel Products are not designed or authorized for use as components in life support appliances, devices or systems where malfunction of a product can reasonably be expected to result in personal injury. Life support devices or systems are devices or systems that (a) are intended for surgical implant into the body or (b) support or sustain life, and whose failure to perform can be reasonably expected to result in a significant injury to the user. A Purchaser's use or sale of Micrel Products for use in life support appliances, devices or systems is at Purchaser's own risk and Purchaser agrees to fully indemnify

Micrel for any damages resulting from such use or sale.

© 2006 Micrel, Incorporated.