

REV	DESCRIPTION	DATE	PREP	APPD
G	05-0727: add 1118 Series and Appendix A	4/7/05	SC	SC



OS-68338 Hi-Rel Clock Oscillator Series

www.vectron.com

EXAMPLES SHOWN IN ACTUAL SIZE

		DATE				VECTRON INTERNATIONAL MOUNT HOLLY SPRINGS, PA 17065	
PREPARED BY	Stan Carpenter	10/26/00	Oscillator Specification, Hybrid Clock Hi-Rel Standard				
QUALITY	SWP	11/1/00					
ENGINEERING	S. Carpenter	10/30/00	CODE IDENT NO	SIZE	DWG. NO.	REV	
			00136	A	OS-68338	G	
UNSPECIFIED TOLERANCES: N/A						SHEET 1 OF 19	

1. SCOPE

1.1 General. This specification defines the design, assembly and functional evaluation of high reliability, hybrid clock oscillators produced by Vectron International. Devices delivered to this specification represent the standardized Parts, Materials and Processes (PMP) Program developed, implemented and certified for advanced applications and extended environments.

1.2 Applications Overview. The designs represented by these products were primarily developed for the MIL-Aerospace community. The lesser Design Pedigrees and Screening Options imbedded within OS-68338 bridge the gap between Space and COTS hardware by providing custom hardware with measures of mechanical, assembly and reliability assurance needed for Military or Ruggedized COTS environments.

2. APPLICABLE DOCUMENTS

2.1 Specifications and Standards. The following specifications and standards form a part of this document to the extent specified herein. The issue currently in effect on the date of quotation will be the product baseline, unless otherwise specified. In the event of conflict between the texts of any references cited herein, the text of this document shall take precedence.

Military

MIL-PRF-55310 Oscillators, Crystal Controlled, General Specification For
MIL-PRF-38534 Hybrid Microcircuits, General Specification For

Standards

MIL-STD-202 Test Method Standard, Electronic and Electrical Component Parts
MIL-STD-883 Test Methods and Procedures for Microelectronics
MIL-STD-1686 Electrostatic Discharge Control Program for Protection of Electrical and Electronic Parts, Assemblies and Equipment

Other

HT-67849 Test Specification, OS-68338 Hybrids, Hi-Rel Standard
QSP-90100 Quality Systems Manual, Vectron International

SIZE A	CODE IDENT NO. 00136	THIRD ANGLE PROJECTION 	UNSPECIFIED TOLERANCES N/A	DWG NO. OS-68338	REV. G	SHEET 2
------------------	--------------------------------	---	--------------------------------------	----------------------------	------------------	-------------------

3. GENERAL REQUIREMENTS

3.1 Classification. All devices delivered to this specification are of hybrid technology conforming to Type 1, Class 2 of MIL-PRF-55310. Primarily developed as a Class S equivalent specification, options are imbedded within it to also produce Class B, Engineering Model and Ruggedized COTS devices. Devices carry a Class 2 ESDS classification.

3.2 Item Identification. External packaging choices are of metal flatpacks, DIP's and ceramic J-lead 9x14mm and LCC's with either TTL or ACMOS logic output. Unique Model Number Series' are utilized to identify device package configurations and output logic as listed in Table 1.

3.3 Absolute Maximum Ratings.

- a. Supply Voltage Range (V_{CC}): -0.5Vdc to +7.0Vdc
- b. Storage Temperature Range (T_{STG}): -65°C to +125°C
- c. Junction Temperature (T_J): +175°C
- d. Lead Temperature (soldering, 10 seconds): +300°C

3.4 Design, Parts, Materials and Processes, Assembly, Inspection and Test.

3.4.1 Design. The ruggedized designs implemented for these devices are proven in military and space applications under extreme environments. Designs utilize 4-point crystal mounting in compliment with Established Reliability (MIL-ER) componentry. When specified, radiation hardening up to 100krad(Si) (RHA level R) can be included without altering the device's internal topography.

3.4.1.1 Design and Configuration Stability. Barring changes to improve performance by reselecting passive chip component values to offset component tolerances, there will not be fundamental changes to the design or assembly or parts, materials and processes after first product delivery of that item without written approval from the procuring activity.

3.4.1.2 Environmental Integrity. Designs have passed the environmental qualification levels of MIL-PRF-55310. These designs have also passed extended dynamic levels of at least:
 Sine Vibration: MIL-STD-202, Method 204, Condition G (30g pk.)
 Random Vibration: MIL-STD-202, Method 214, Condition II-J (43.92g rms)
 Mechanical Shock: MIL-STD-202, Method 213, Condition F (1500g, 0.5ms)

3.4.2 Prohibited Parts, Materials and Processes. The items listed are prohibited for use in high reliability devices produced to this specification.

- a. Gold metallization of package elements without a barrier metal.
- b. Zinc chromate as a finish.
- c. Cadmium, zinc, or pure tin external or internal to the device.
- d. Plastic encapsulated semiconductor devices.
- e. Ultrasonically cleaned electronic parts.

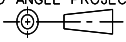
SIZE A	CODE IDENT NO. 00136	THIRD ANGLE PROJECTION 	UNSPECIFIED TOLERANCES N/A	DWG NO. OS-68338	REV. G	SHEET 3
------------------	--------------------------------	---	--------------------------------------	----------------------------	------------------	-------------------

f. Heterojunction Bipolar Transistor (HBT) technology.

- 3.4.3 Assembly. Manufacturing utilizes standardized procedures, processes and verification methods to produce MIL-PRF-55310 Class S / MIL-PRF-38534 Class K equivalent devices. MIL-PRF-38534 Group B Option 1 in-line inspection is included on radiation hardened part numbers to further verify lot pedigree. Traceability of all components and production lots are in accordance with MIL-PRF-38534, as a minimum. Tabulated records are provided as a part of the deliverable data package. Devices are handled in accordance with MIL-STD-1686 for Class 1 devices.
- 3.4.4 Inspection. The inspection requirements of MIL-PRF-55310 apply to all devices delivered to this document. Inspection conditions and standards are documented in accordance with the Quality Assurance, ISO-9001 derived, System of QSP-90100.
- 3.4.5 Test. The Screening test matrix of Table 5 is tailored for selectable-combination testing to eliminate costs associated with the development/maintenance of device-specific documentation packages while maintaining performance integrity.
- 3.4.6 Marking. Device marking shall be in accordance with the requirements of MIL-PRF-55310.
- 3.4.7 Ruggedized COTS Design Implementation. Design Pedigree “D” devices (see ¶ 5.2) use the same robust designs found in the other device pedigrees. They do not include the provisions of traceability or the Class-qualified componentry noted in paragraphs 3.4.3 and 4.1.

4. DETAIL REQUIREMENTS

4.1 Components

- 4.1.1 Crystals. Cultured quartz crystal resonators are used to provide the selected frequency for the devices. The optional use of Premium Q swept quartz can, because of its processing to remove impurities, be specified for better frequency aging characteristics. In accordance with MIL-PRF-55310, the manufacturer has a documented crystal element evaluation program.
- 4.1.2 Passive Components. Established Reliability (ER) failure level R passive components are procured from QPL suppliers. Lot evaluations are in accordance with MIL-PRF-55310.
- 4.1.3 Class S Microcircuits. Microcircuits are procured from wafer lots that have passed MIL-PRF-55310 Lot Acceptance Tests for Class S devices. The prescribed die carries a Class 2 ESDS classification in accordance with MIL-PRF-38535. When optionally specified, further testing in accordance with MIL-PRF-55310 and MIL-PRF-38534 is performed for

SIZE A	CODE IDENT NO. 00136	THIRD ANGLE PROJECTION 	UNSPECIFIED TOLERANCES N/A	DWG NO. OS-68338	REV. G	SHEET 4
------------------	--------------------------------	---	--------------------------------------	----------------------------	------------------	-------------------

radiation hardness assurance. Those microcircuits, identified by a unique part number, are certified for 100krad(Si) total ionizing dose (TID), RHA level R (2X minimum margin). NSC, as the 54ACT designer, rates the SEU LET at >40 MeV and SEL at >120MeV for the FACT™ family (AN-932). Our wafer testing does not include these parameters and determinations, but by design similarity.

4.1.3.1 Class B Microcircuits. When specified, microcircuits assembled into OS-68338 Design Pedigree letters “B” and “C” devices (¶ 5.2a) are procured from wafer lots that have passed MIL-PRF-55310 element evaluations for Class B devices.

4.1.4 Packages. Packages are procured that meet the construction, lead materials and finishes as specified in MIL-PRF-55310. Package lots are upscreened in accordance with the requirements of MIL-PRF-38534 as applicable.

4.1.5 Traceability. Active device lots are homogenous and traceable to the manufacturer’s individual wafer. Crystals are traceable to the quartz bar and the processing details of the autoclave lot, as applicable. All other elements and materials are traceable to their incoming inspection lots.

4.2 Mechanical.

4.2.1 Package Outline. Table 1 links each Hi-Rel Standard Model Number of this specification to a corresponding package style. Mechanical Outline information of each package style is found in the referenced Figure.

4.2.2 Thermal Characteristics. The worst case thermal characteristics of each package style are found in Table 4.

4.3 Electrical.

4.3.1 Input Power. Devices are designed for standard 5.0 volt dc operation, ±10%. Optional 3.3 Vdc (±10%) input performance for ACMOS output conditions. Current is measured, no load, at maximum rated operating voltage.

4.3.2 Temperature Range. Operating range is -55°C to +125°C.

4.3.3 Frequency Tolerance. Initial accuracy at +23°C is ±15 ppm maximum. Frequency-Temperature Stability is ±50 ppm maximum from +23°C reference. Frequency-Voltage Tolerance is ±4 ppm maximum.

4.3.4 Frequency Aging. Aging limits, and when tested in accordance with MIL-PRF-55310 Group B inspection, shall not exceed ±1 ppm the first 30 days, ±5 ppm Year 1 and ±2 ppm per year thereafter.

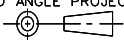
SIZE A	CODE IDENT NO. 00136	THIRD ANGLE PROJECTION 	UNSPECIFIED TOLERANCES N/A	DWG NO. OS-68338	REV. G	SHEET 5
------------------	--------------------------------	---	--------------------------------------	----------------------------	------------------	-------------------

4.3.5 Operating Characteristics. Symmetrical square wave limits are dependent on the device frequency and are in accordance with Tables 2 and 2A. Waveform measurement points and logic limits are in accordance with MIL-PRF-55310. Start-up time is 10.0 msec. maximum.

4.3.6 Output Load. Standard TTL (6 or 10) and ACMOS (10kΩ, 15pF) test loads are in accordance with MIL-PRF-55310.

5. QUALITY ASSURANCE PROVISIONS AND VERIFICATION

5.1 Verification and Test. Device lots shall be tested prior to delivery in accordance with the applicable Screening Option letter as stated by the 15th character of the part number. Table 5 tests are conducted in the order shown and annotated on the appropriate process travelers and data sheets of the governing test procedure.

5.1.1 Screening Options. The Screening Options, by letter, are summarized as:

- A Modified MIL-PRF-38534 Class K
- B Modified MIL-PRF-55310 Class B Screening & Group A Quality Conformance Inspection (QCI)
- C Modified MIL-PRF-55310 Class S Screening & Group A QCI
- D Modified MIL-PRF-38534 Class K with Burn-in Delta Aging
- E Modified MIL-PRF-55310 Class B Screening, Groups A & B QCI
- F MIL-PRF-55310 Class S Screening, Groups A & B QCI
- G MIL-PRF-55310 Class B Screening & Group A QCI
- X Engineering Model (EM)

5.2 Optional Design, Test and Data Parameters. The following is a list of design, assembly, inspection and test options that can be selected or added by purchase order request.

- a. Design Pedigree (choose one as the 5th character in the part number):
 - (R) Hi-Rel design w/ 100krad Class S die, Premium Q Swept Quartz
 - (V) Hi-Rel design w/ 100krad Class S die, Cultured Quartz
 - (X) Hi-Rel design w/ Cultured Quartz, Class S die
 - (B) Hi-Rel design w/ Swept Quartz, Class B die
 - (C) Hi-Rel design w/ Cultured Quartz, Class B die
 - (D) Hi-Rel design w/ Cultured Quartz and commercial grade components
- b. Input Voltage, (A) for 5.0V, (B) for 3.3V as the 14th character
- c. Frequency-Temperature Slew Test
- d. Radiographic Inspection
- e. Group C Inspection: MIL-PRF-55310
- f. Group C Inspection: MIL-PRF-38534
- g. Internal Water-Vapor Content (RGA) samples and test performance
- h. MTBF Reliability Calculations
- i. Worst Case/Derating Analysis
- j. Deliverable Process Identification Documentation (PID)
- k. Customer Source Inspection (pre-cap / final)

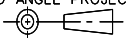
SIZE A	CODE IDENT NO. 00136	THIRD ANGLE PROJECTION 	UNSPECIFIED TOLERANCES N/A	DWG NO. OS-68338	REV. G	SHEET 6
------------------	--------------------------------	---	--------------------------------------	----------------------------	------------------	-------------------

- 5.3 Test Conditions. Unless otherwise stated herein, inspections are performed in accordance with those specified in MIL-PRF-55310 and MIL-PRF-38534, in that order. Process travelers identify the applicable methods, conditions and procedures to be used. Examples of electrical test procedures that correspond to MIL-PRF-55310 requirements are shown in Table 3.
- 5.4 Special Tests and Descriptions.
- 5.4.1 Frequency-Temperature Slew. Frequency-Temperature Slew Test has been developed as an indicator of higher than normal internal water vapor content. The incremental temperature sweep from +125°C to -55°C and back to +125°C records output frequency fluctuations emulating the mass loading of moisture deposited on the crystal blank surface. Though not replacing a customer's internal water-vapor content (RGA) requirement, confidence is increased without destructively testing otherwise good devices.
- 5.4.2 Burn-in Delta Frequency Aging (in Option D). The frequency measurement for burn-in delta measurements is performed at the crystal's upper turning point temperature where its effects on repeatable frequency accuracy are maximized. Dependent on the crystal specified, this temperature is typically between +65°C and +85°C, ±0.2°C.
- 5.5 Deliverable Data. The manufacturer supplies the following data, as a minimum, with each lot of devices:
- a. Completed assembly and screening lot travelers, including rework history.
 - b. Electrical test variables data, identified by unique serial number.
 - c. Frequency-Temperature Slew plots, Radiographic films, Group C data and RGA data as required by purchase order.
- 5.6 Discrepant Material. All MRB authority resides with the procuring activity.
- 5.7 Failure Analysis. Any catastrophic failure (no clocking, no current) at Post Burn-In or after will be evaluated for root cause. The customer will be notified after occurrence and upon completion of the evaluation.
6. PREPARATION FOR DELIVERY
- 6.1 Packaging. Devices will be packaged in a manner that prevents handling and transit damage during shipping. Devices will be handled in accordance with MIL-STD-1686 for Class 1 devices.

SIZE A	CODE IDENT NO. 00136	THIRD ANGLE PROJECTION 	UNSPECIFIED TOLERANCES N/A	DWG NO. OS-68338	REV. G	SHEET 7
------------------	--------------------------------	---	--------------------------------------	----------------------------	------------------	-------------------

7. ORDERING INFORMATION

7.1 Ordering Part Number. The ordering part number is made up of an alphanumeric series of 15 characters. Design-affected product options, identified by the parenthetic letter on the Optional Parameters list (¶ 5.2a and b), are included within the device part number.

The Part Number breakdown is described as:

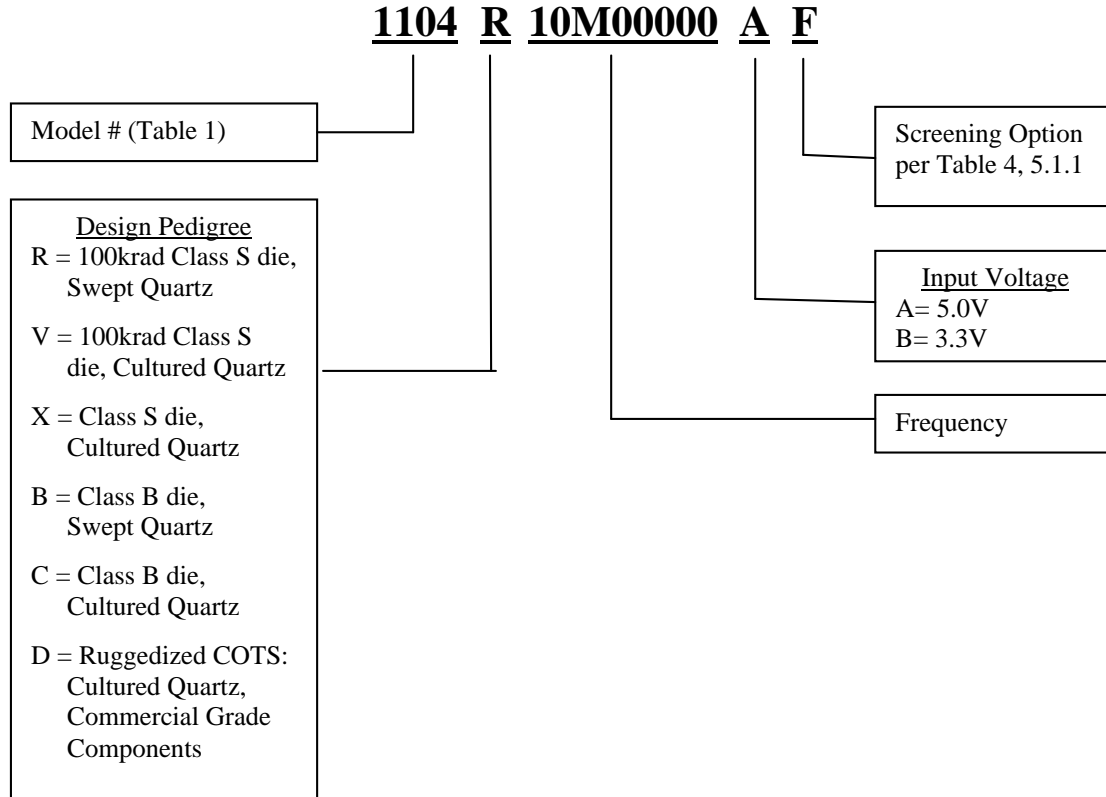

7.1.1 Model Number. The device model number is the four (4) digit number assigned to a corresponding package and output combination per Table 1.

7.1.2 Design Pedigree. Class S variants correspond to either letter “R”, “V” or “X” and are described in paragraph 5.2a. Class B variants correspond to either letter “B” or “C” and are described in paragraph 5.2a. Ruggedized COTS, using commercial grade components, corresponds to letter “D”.

7.1.2.1 Input Voltage. Voltage is the 14th character, letters “A” representing 5.0V and “B” for 3.3V.

7.1.3 Output Frequency. The nominal output frequency is expressed in the format as specified in MIL-PRF-55310 utilizing eight (8) characters.

SIZE	CODE IDENT NO.	THIRD ANGLE PROJECTION	UNSPECIFIED TOLERANCES	DWG NO.	REV.	SHEET
A	00136		N/A	OS-68338	G	8

7.1.4 Screening Options. The 15th character is the Screening Option (letter A thru G or X) selected from Table 4.

7.2 Optional Design, Test and Data Parameters. Test and documentation requirements above that of the standard high reliability model shall be specified by separate purchase order line items (as listed in ¶ 5.2c thru k).

HI-REL STANDARD MODEL #	PACKAGE	OUTPUT, Square Wave	PIN I/O 1/				MECHANICAL OUTLINE
			Vcc	Out	Gnd/Case	E/D	
1101	12 Lead Flatpack	ACMOS	12	7	6	na	FIGURE 1
1102	14 Lead Flatpack	ACMOS	14	8	7	na	FIGURE 2
1103	16 Lead Flatpack	ACMOS	8	10	9	na	FIGURE 3
1104	20 Lead Flatpack	ACMOS	13, 20	11	10	na	FIGURE 6
1105	14 Pin DIP	ACMOS	14	8	7	na	FIGURE 7
1106	20 Lead LCC	ACMOS	4	39	37	na	FIGURE 4
1113	40 Pad LCC	ACMOS	4	39	37	na	FIGURE 4
1115	4 pin 1/2 DIP	ACMOS	8	5	4	na	FIGURE 5
1116	J-lead SMT	ACMOS	4	3	2	1	FIGURE 8
1118	4 pad 5 x 7mm	ACMOS	4	3	2	1	FIGURE 9
1107	12 Lead Flatpack	TTL	12	7	6	na	FIGURE 1
1108	14 Lead Flatpack	TTL	14	8	7	na	FIGURE 2
1109	16 Lead Flatpack	TTL	8	10	9	na	FIGURE 3
1110	20 Lead Flatpack	TTL	13, 20	11	10	na	FIGURE 6
1111	14 Pin DIP	TTL	14	8	7	na	FIGURE 7
1112	20 Lead LCC	TTL	4	39	37	na	FIGURE 4
1114	40 Pad LCC	TTL	4	39	37	na	FIGURE 4
1117	J-lead SMT	TTL	4	3	2	1	FIGURE 8

1/. All unassigned pins have no internal connections or ties.

TABLE 1 - Item Identification and Package Outline

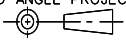
SIZE A	CODE IDENT NO. 00136	THIRD ANGLE PROJECTION 	UNSPECIFIED TOLERANCES N/A	DWG NO. OS-68338	REV. G	SHEET 9
------------------	--------------------------------	---	--------------------------------------	----------------------------	------------------	-------------------

Temperature Range: -55°C to +125°C					
Frequency Tolerance, Initial Accuracy @ +23°C: ±15 ppm max.					
Frequency-Temperature Stability from +23°C ref.: ±50 ppm max.					
Frequency-Voltage Tolerance: ±4 ppm max. (Vcc ±10%)					
Frequency Aging: ±1 ppm max. 1 st 30 days, ±5 ppm max. Year 1, ±2 ppm max. Year 2+					
Start-up Time: 10.0 ms max.					
Frequency Range (MHz)	Current (mA) (max. no load)		Rise / Fall Times (ns max.)	Duty Cycle (%)	Fan-out (if TTL)
	5.5V	3.63V			
0.35 - 4.0	10	6	6	45 to 55	10
4.0 – 12.0	15	8	5	45 to 55	10
>12.0 – 24.0	15	10	5	40 to 60	10
>24.0 – 40.0	20	15	5	40 to 60	6
>40.0 – 65.0	35	20	5	40 to 60	6
>65.0 – 80.0	45	25	3	40 to 60	6
>80.0 – 100	55	30	3	40 to 60	

2/. Waveform measurement points and logic limits are in accordance with MIL-PRF-55310.

TABLE 2 - Electrical Performance Characteristics

OPERATION LISTING	REQUIREMENTS AND CONDITIONS	VECTRON TEST PROCEDURE
@ all Electrical tests		
Input Current (no load)	MIL-PRF-55310, Para 4.8.5.1	GR-51681
Initial Accuracy @ Ref. Temp.	MIL-PRF-55310, Para 4.8.6	GR-51596
Output Logic Voltage Levels	MIL-PRF-55310, Para 4.8.21.3	GR-51597
Rise and Fall Times	MIL-PRF-55310, Para 4.8.22	GR-51599
Duty Cycle	MIL-PRF-55310, Para 4.8.23	GR-51601
@ Post Burn-In Electrical only		
Overvoltage Survivability	MIL-PRF-55310, Para 4.8.4	GR-37269
Initial Freq. – Temp. Accuracy	MIL-PRF-55310, Para 4.8.10.1	GR-51602
Freq. – Voltage Tolerance	MIL-PRF-55310, Para 4.8.14	GR-51602
Start-up Time (fast/slow start)	MIL-PRF-55310, Para 4.8.29	GR-61352

TABLE 3 - Electrical Test Parameters

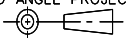
SIZE A	CODE IDENT NO. 00136	THIRD ANGLE PROJECTION 	UNSPECIFIED TOLERANCES N/A	DWG NO. OS-68338	REV. G	SHEET 10
------------------	--------------------------------	---	--------------------------------------	----------------------------	------------------	--------------------

Model #	Thermal Resistance Junction to Case θ_{jc} ($^{\circ}\text{C} / \text{W}$)	Δ Junction Temp. T_j ($^{\circ}\text{C}$ @ max. I_{cc})
1101 / 1107	17.32	5.24
1102 / 1108	17.32	5.24
1103 / 1109	17.20	5.20
1104 / 1110	16.97	5.13
1105 / 1111	19.57	5.92
1106 / 1112	4.38	1.33
1113 / 1114	4.38	1.33
1115	20.22	6.12
1116 / 1117	17.91	5.42
1118	3.77	1.14

Maximum operating power = 302.5 mW per Table 2.

TABLE 4 - Thermal Characteristics

SIZE A	CODE IDENT NO. 00136	THIRD ANGLE PROJECTION 	UNSPECIFIED TOLERANCES N/A	DWG NO. OS-68338	REV. G	SHEET 11
------------------	--------------------------------	---	--------------------------------------	----------------------------	------------------	--------------------

OPN. NO.	OPERATION LISTING	REQUIREMENTS AND CONDITIONS	Option A	Option B	Option C	Option D	Option E
	SCREENING	MIL Class Similarity	K	B-	S-	K+	B+
			100%	100%	100%	100%	100%
1	Non-Destruct Bond Pull	MIL-STD-883, Meth 2023	Completer During Assen				
2	Internal Visual	MIL-STD-883, Meth 2017 Cond H, Meth 2032 Cond M					
3	Stabilization (Vacuum) Bake	MIL-STD-883, Meth 1008, Cond C, 150°C, 48 hours min.					
4	Thermal Shock	MIL-STD-883, Meth 1011, Cond A	NR	NR	X	NR	NR
5	Temperature Cycle	MIL-STD-883, Meth 1010, Cond. B, 10 cycles min.	X	X	X	X	X
6	Constant Acceleration	MIL-STD-883, Meth 2001, Cond A, Y1 plane only, 5000 g's	X	X	X	X	X
7	Particle Impact Noise Detection	MIL-STD-883, Meth 2020, Cond B	X	X	X	X	X
8	Electrical Testing, Pre Burn-In	Perform tests in Table 3. Nominal Vcc, nominal temperature	X	X	X	X, <u>3/</u>	X
9	Freq-Temp Slew Test	Operating temp. range, frequency plotted at 1.0°C steps	AR	AR	AR	AR	AR
10	1 st Burn-In	MIL-STD-883, Meth 1015, + 125°C	X 160 hrs.	X 160 hrs.	X 240 hrs.	X 160 hrs.	X 160 hrs.
11	Electrical Testing, Intermediate	Perform tests in Table 3. Nominal Vcc, nominal temperature	X	NR	NR	X, <u>4/</u>	NR
12	2 nd Burn-In	MIL-STD-883, Meth 1015, + 125°C	X 160 hrs.	NR	NR	X 160 hrs.	NR
13	Electrical Testing, Post Burn-In (Group A)	Perform tests in Table 3. Nominal Vcc & extremes, nominal temperature & extremes	X	X	X	X, <u>5/</u>	X
14	Seal: Fine Leak	MIL-STD-883, Meth 1014, Cond A2 5 x 10 ⁻⁸ atm cc/sec max	X	X	X	X	X
15	Seal: Gross Leak	MIL-STD-202, Meth 112, Cond D	X	X	X	X	X
16	Radiographic Inspection	MIL-STD-883, Meth 2012	X	AR	AR	X	AR
17	Solderability	MIL-STD-883, Meth 2003	<u>6/</u>	<u>6/</u>	<u>6/</u>	<u>6/</u>	<u>6/</u>
18	External Visual & Mechanical	MIL-STD-883, Meth 2009	X <u>7/</u>	X <u>7/</u>	X <u>7/</u>	X <u>7/</u>	X <u>7/</u>
19	Aging, 30 Day (M55310 Group B)	MIL-PRF-55310, para. 4.8.35.1	NR	NR	NR	NR	13 pcs.

LEGEND: X = Required, NR = Not Required, AR = As Required

TABLE 5 - Test Matrix

3/ includes frequency recorded at the crystal Upper Turning Point (UTP) temperature. 4/ Δ_F @ UTP = ± 7.5 ppm maximum.

5/ Δ_F @ UTP = ± 2.5 ppm maximum. 6/ Performed at package LAT. Include LAT data sheet

7/ When specified, RGA samples will be removed from the lot after completion of this operation. Use of Screening failures require custo

SIZE A	CODE IDENT NO. 00136	THIRD ANGLE PROJECTION 	UNSPECIFIED TOLERANCES N/A	DWG NO. OS-68338	REV. G
------------------	--------------------------------	---	--------------------------------------	----------------------------	------------------

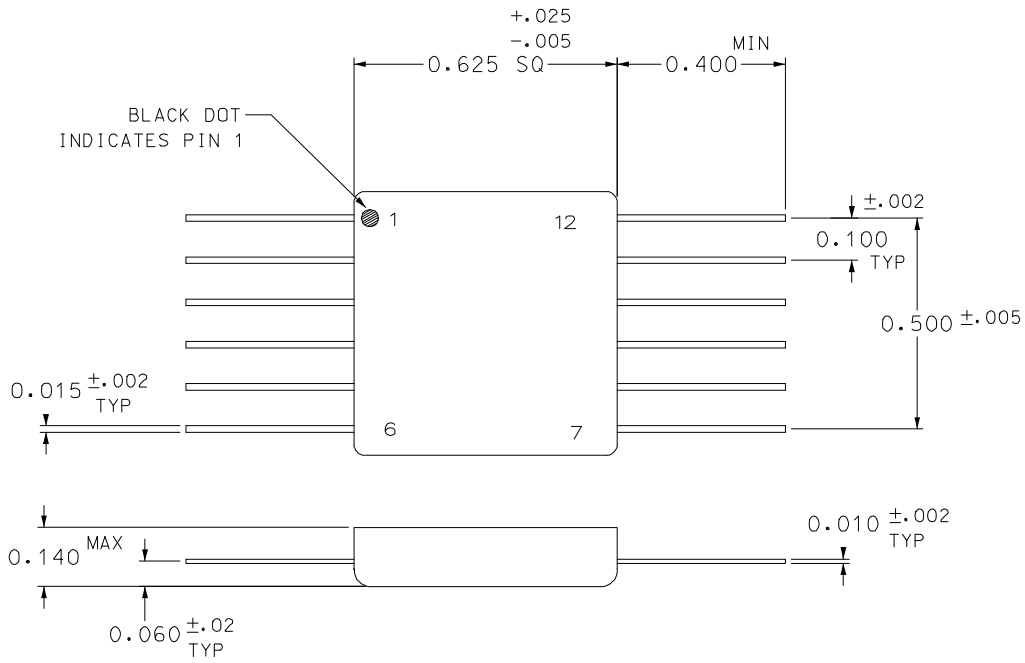

FIGURE 1
Models 1101 & 1107 Package Outline

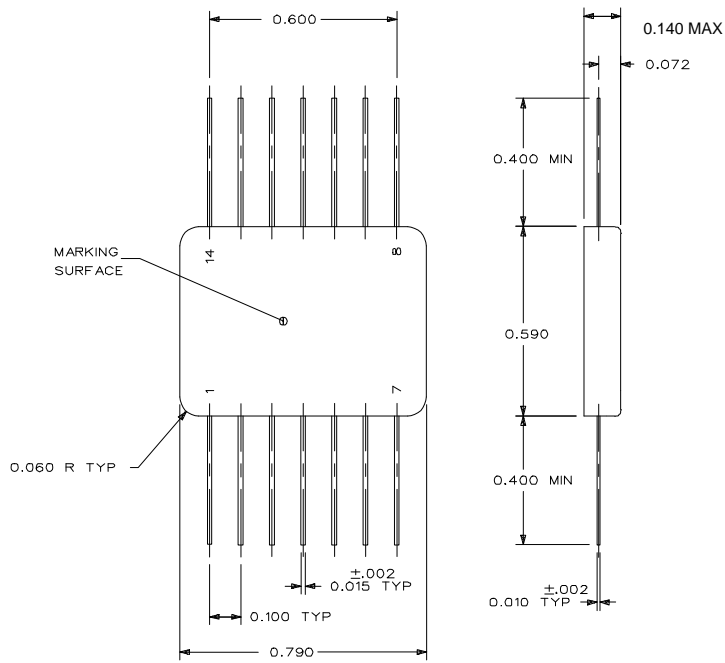
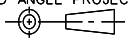

FIGURE 2
Models 1102 & 1108 Package Outline

SIZE	CODE IDENT NO.	THIRD ANGLE PROJECTION	UNSPECIFIED TOLERANCES	DWG NO.	REV.	SHEET
A	00136		N/A	OS-68338	G	13

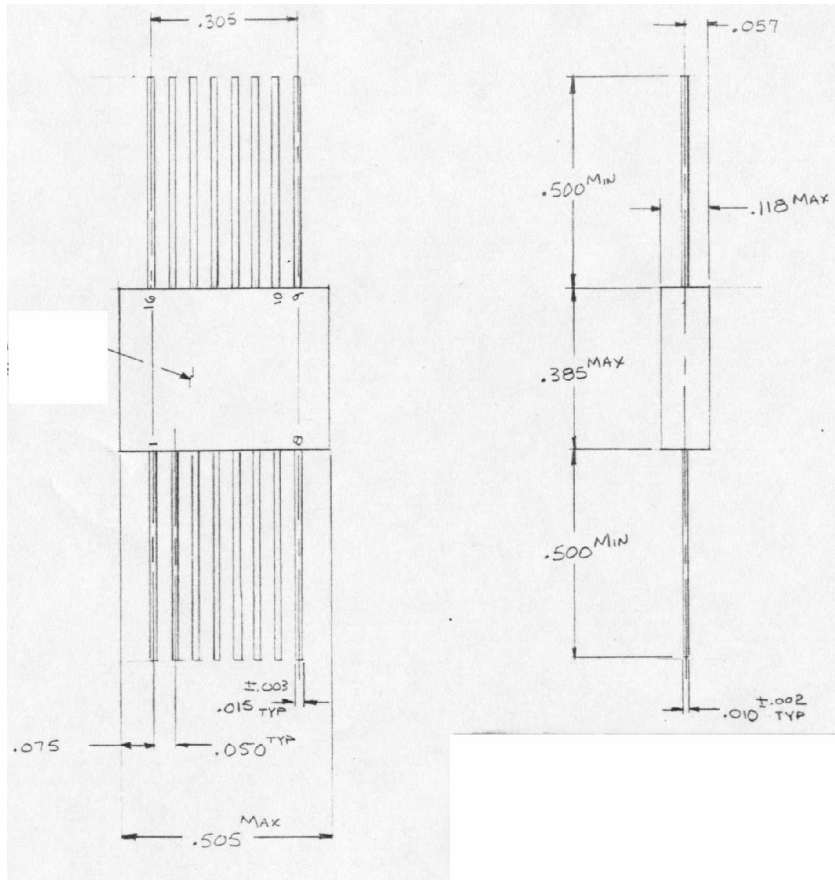

FIGURE 3
Models 1103 & 1109 Package Outline

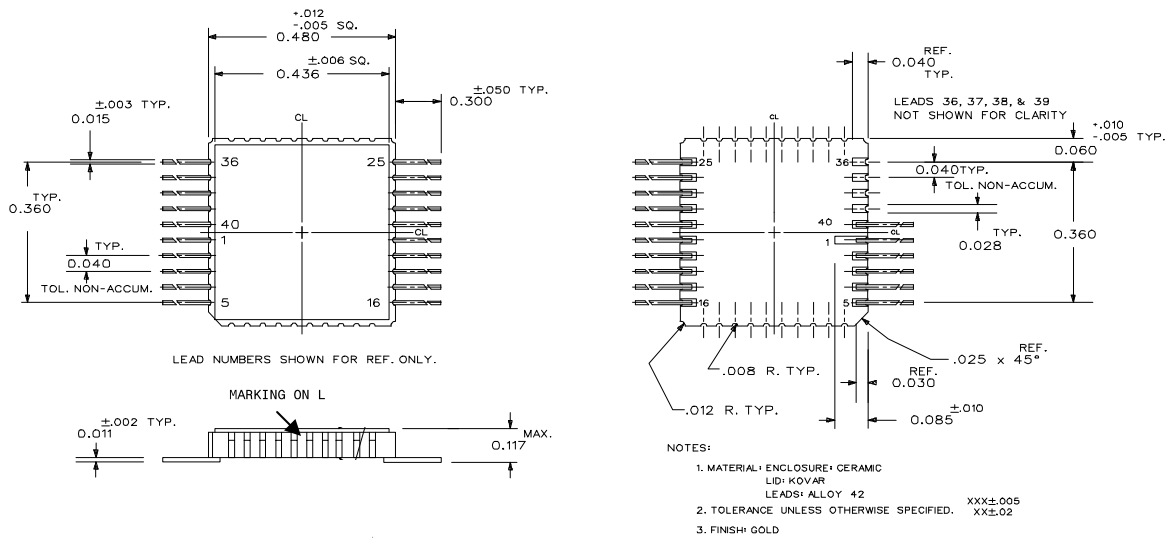

FIGURE 4
Models 1106 & 1112 Package Outline
Models 1113 & 1114 - same package minus the leads

SIZE	CODE IDENT NO.	THIRD ANGLE PROJECTION	UNSPECIFIED TOLERANCES	DWG NO.	REV.	SHEET
A	00136		N/A	OS-68338	G	14

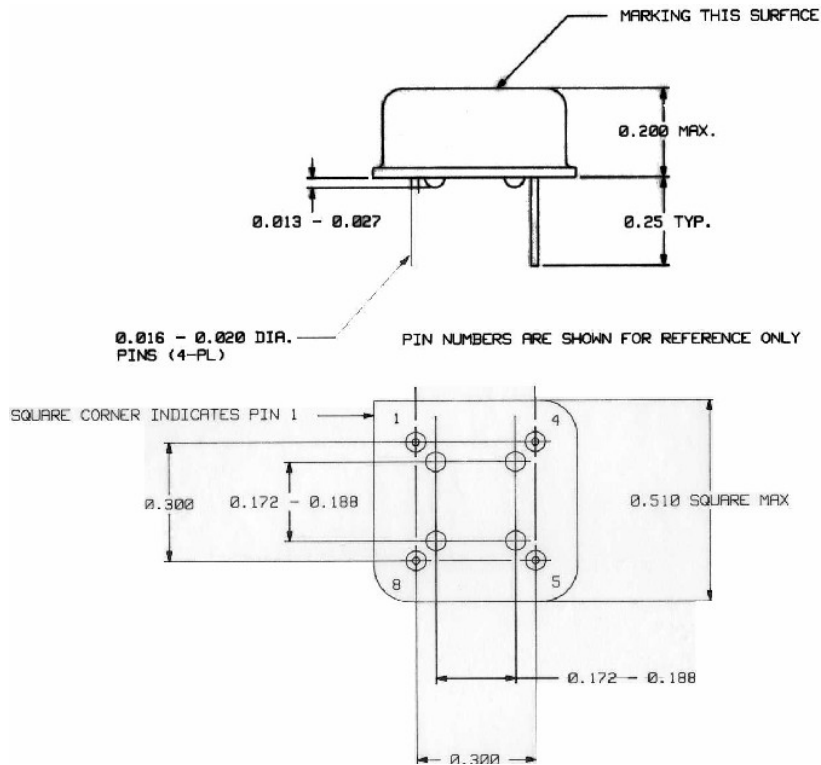

FIGURE 5
Model 1115 Package Outline

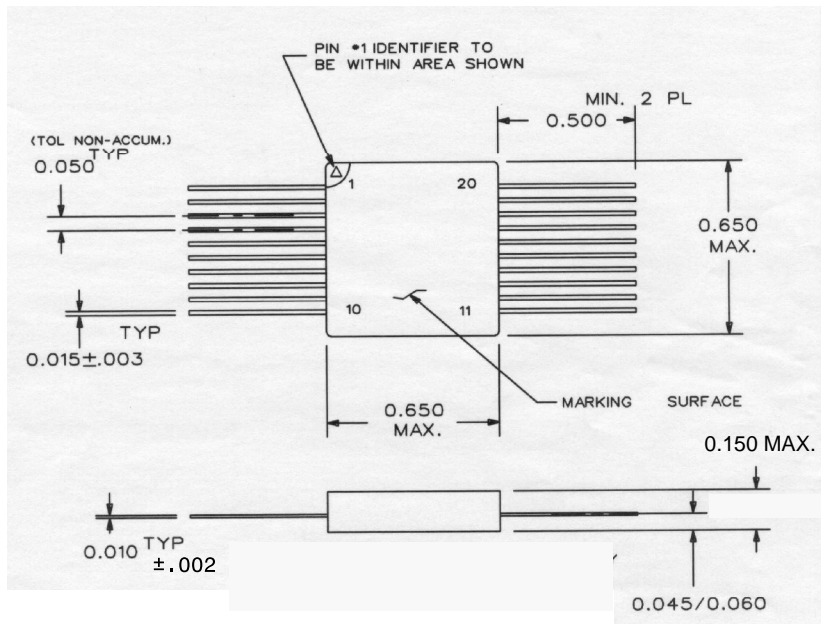

FIGURE 6
Model 1104 & 1110 Package Outline

SIZE	CODE IDENT NO.	THIRD ANGLE PROJECTION	UNSPECIFIED TOLERANCES	DWG NO.	REV.	SHEET
A	00136		N/A	OS-68338	G	15

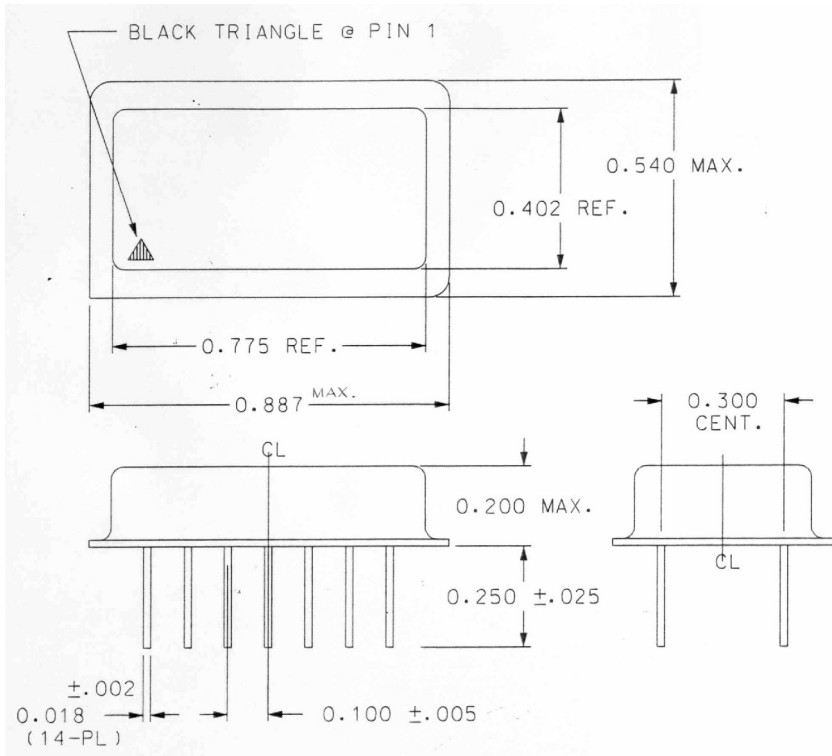

FIGURE 7
Model 1105 & 1111 Package Outline

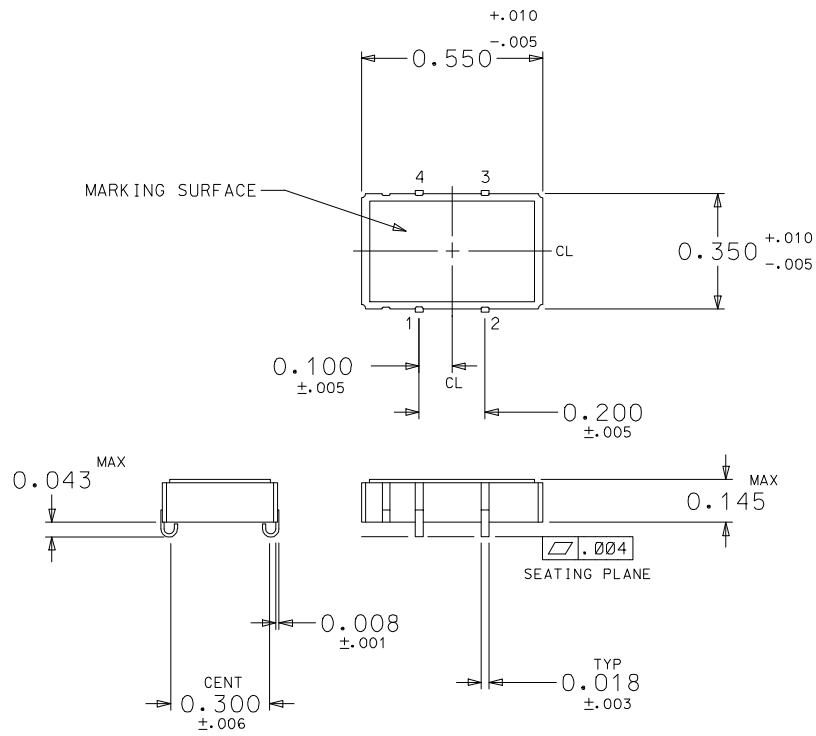
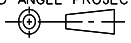

FIGURE 8
Model 1116 & 1117 Package Outline

SIZE	CODE IDENT NO.	THIRD ANGLE PROJECTION	UNSPECIFIED TOLERANCES	DWG NO.	REV.	SHEET
A	00136		N/A	OS-68338	G	16

APPENDIX A

4 Pad 5 x 7mm ACMOS Hybrid, Model Number 1118 Series

A.1 Scope. The Model 1118 Series uses a fundamentally different design approach versus the other models offered by the OS-68338 Specification. Some of that text does not fit this design, so for that reason the Model 1118 Series is specified here in Appendix A. Where not superseded by this Appendix the original text still applies.

A.2 Design. The Model 1118 Series uses an AT-strip crystal mounted at two adjacent points. Due to the crystal's smaller mass this 2-point design has proven its ruggedness by passing the same environmental qualification exposures of the other OS-68338 Models (¶ 3.4.1.2).

A.3 Availability. The Model 1118 Series will not be available in the "R" and "B" Design Pedigrees (¶ 5.2a) until a qualified source for traceable, swept quartz AT-strip crystals is developed.

A.4 Performance

Temperature Range: -55°C to +125°C					
Frequency Tolerance, Initial Accuracy @ +23°C: ±15 ppm max.					
Frequency-Temperature Stability from +23°C ref.: ±75 ppm max.					
Frequency-Voltage Tolerance: ±4 ppm max. (Vcc ±10%)					
Frequency Aging: ±1 ppm 1 st 30 days, ±5 ppm max. Year 1, ±2 ppm max. Year 2+					
Start-up Time: 10.0 ms max.					
Frequency Range (MHz)	Current (mA) (max. no load)		Rise / Fall Times (ns max.)	Duty Cycle (%)	
0.7 - 4.0	10	6	6	45 to 55	
4.0 – 12.0	15	8	5	45 to 55	
>12.0 – 24.0	15	10	5	40 to 60	
>24.0 – 40.0	20	15	5	40 to 60	
>40.0 – 50.0	35	20	5	40 to 60	

2/. Waveform measurement points and logic limits are in accordance with MIL-PRF-55310.

TABLE 2A - Electrical Performance Characteristics, Model 1118 Series

A.5 Marking. Device marking, due to size, will be limited to the Vectron logo (VI), date code, Pin 1 / ESD ID and the fully traceable Work Order – unique serial number combination, i.e. 370002-20. Individual device packaging will include the full part number.

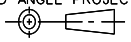
SIZE A	CODE IDENT NO. 00136	THIRD ANGLE PROJECTION 	UNSPECIFIED TOLERANCES N/A	DWG NO. OS-68338	REV. G	SHEET 17
------------------	--------------------------------	---	--------------------------------------	----------------------------	------------------	--------------------

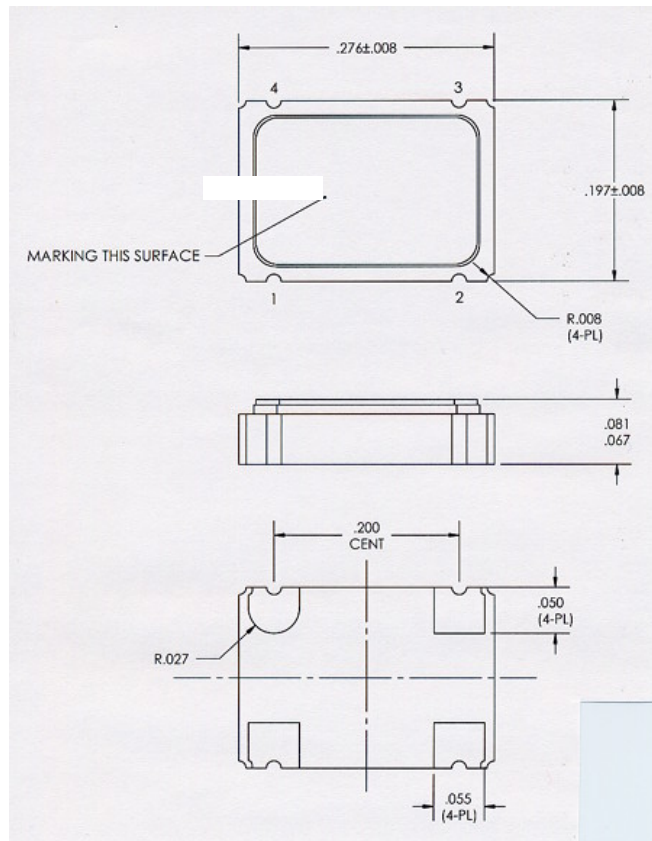
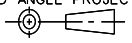

FIGURE 9
Model 1118 Package Outline

SIZE	CODE IDENT NO.	THIRD ANGLE PROJECTION	UNSPECIFIED TOLERANCES	DWG NO.	REV.	SHEET
A	00136		N/A	OS-68338	G	18

DOCUMENT CHANGE RECORD

Revision	Change
E	<p>ECO 03-1573</p> <p>Add MIL-STD-202 to Applicable Documents Add ESDS Class 2 references: ¶ 3.1, 4.1.3 Add Absolute Maximum Ratings: insert new ¶ 3.3, renumber thereafter Add Prohibited PM&P: insert ¶ 3.4.2 Add the number of characters to part number segments: ¶ 7.1.1, 7.1.3 Table 1: add Pin I/Os correct total 1116/1117 package height, incl. ‘J’ leads to 0.190” add Note 1 and “Package Info” in On-Line column Table 2: number notation as Note 2 Table 4: renumber Notes to numbers 3 thru 7 Add Package Outlines: Figures 1 thru 5</p>
F	<p>ECO 04-2126</p> <p>Add Application Overview: ¶ 1.2 Add new para. for Ruggedized COTS: ¶ 3.4.7 Add Design Pedigree ‘D’: ¶ 5.2, 7.1 Add references to Ruggedized COTS: ¶ 3.1, 7.1.2 Add Screening Option ‘G’: ¶ 5.1.1, 7.1.4 Table 1: change all HCMOS or ACMOS, replace MIL package references with applicable added Figures Table 4: add Screening Options ‘G’ and ‘EM’ Add Figures 6 thru 8</p>
G	<p>ECO 05-0727</p> <p>Add ¶ 3.4.1.2 Environmental Integrity ¶ 4.1.3: add SEU / SEL statement ¶ 4.3.1: change 3.3Vdc tolerance from ±5% to ±10% ¶ 4.3.4: revised Aging from ±5 ppm / year max. to ±5 ppm max. Year 1, ±2 ppm max. Year 2+ ¶ 5.2: add (V) Hi-Rel design w/ 100krad Class S die, Cultured Quartz ¶ 7.1 Design Pedigree: add V=100krad Class S die, Cultured Quartz Table 1: add 1118 Model Number info Table 2, Current column: split into 5.5V and 3.6V columns and revised limits downward Table 2, Rise/Fall Times column: revise limits downward for ≤12 MHz and >65.0 to 80 MHz ranges Add new Table 4 Thermal Characteristics, renumber Test Matrix to Table 5 Table 5 Test Matrix, Option X column: correct Opn. No. 5, 6 and 17 from “X” to “N/R” Add Appendix A for 5 x 7 requirements</p>

SIZE A	CODE IDENT NO. 00136	THIRD ANGLE PROJECTION 	UNSPECIFIED TOLERANCES N/A	DWG NO. OS-68338	REV. G	SHEET 19
------------------	--------------------------------	---	--------------------------------------	----------------------------	------------------	--------------------