

1°C Dual SMBus Sensor with Resistance Error Correction

PRODUCT FEATURES

Data Brief

General Description

The EMC1002 is an SMBus temperature sensor that monitors up to two temperature zones and can generate two system interrupts. With $\pm 1^\circ\text{C}$ measurement accuracy, the EMC1002 provides a low-cost solution for critical temperature monitoring applications. Extended features include automatic resistance error correction and programmable ideality factor configuration eliminating both major sources of temperature measurement error.¹ The 11-bit sigma delta temperature-to-digital converter provides superb linearity, excellent noise immunity and repeatable temperature readings.

The EMC1002 generates two separate interrupts with programmable thermal trip points. The THERM output operates as a thermostat with programmable threshold and hysteresis. The ALERT output can be configured as a maskable SMBus alert with programmable window comparator limits, or a second THERM output.

The EMC1002 is pin compatible with the ADT7461, ADM1032, LM99, and the MAX6649.

¹. Patents pending.

Features

- Resistance Error Correction
- Ideality Factor Configuration
- Select 1 of 4 SMBus addresses with external resistor
- Remote Thermal Zones
 - $\pm 1^\circ\text{C}$ Accuracy (40°C to 80°C)
 - 0.125°C resolution
- Internal Thermal Zone
 - $\pm 3^\circ\text{C}$ Accuracy (0°C to 85°C)
- Maskable Interrupt using ALERT
- One-shot Command during standby
- Programmable temperature conversion rate
- Extended temperature (-64°C to 191°C) available
- Over-limit filtering with consecutive counter
- Small 8-pin MSOP lead-free RoHS Compliant package

Applications

- Desktop and Notebook Computers
- Smart batteries
- Industrial/Automotive
- Other Electronic Systems

Simplified Block Diagram

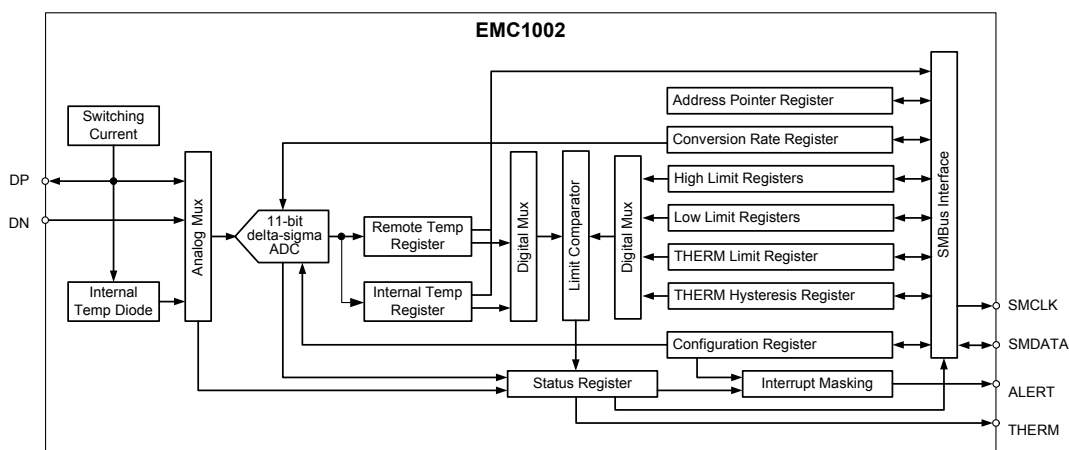

ORDER NUMBERS:

EMC1002-1-ACZL-TR for 8 pin, MSOP Lead-Free RoHS Compliant package (Fixed Address, Tape and Reel)
EMC1002-2-ACZL-TR for 8 pin, MSOP Lead-Free RoHS Compliant package (Variable Address, Tape and Reel)

Reel size is 4,000 pieces.

Evaluation Board available upon request. (EVB-EMC1002)



80 ARKAY DRIVE, HAUPPAUGE, NY 11788 (631) 435-6000, FAX (631) 273-3123

Copyright © 2008 SMSC or its subsidiaries. All rights reserved.

Circuit diagrams and other information relating to SMSC products are included as a means of illustrating typical applications. Consequently, complete information sufficient for construction purposes is not necessarily given. Although the information has been checked and is believed to be accurate, no responsibility is assumed for inaccuracies. SMSC reserves the right to make changes to specifications and product descriptions at any time without notice. Contact your local SMSC sales office to obtain the latest specifications before placing your product order. The provision of this information does not convey to the purchaser of the described semiconductor devices any licenses under any patent rights or other intellectual property rights of SMSC or others. All sales are expressly conditional on your agreement to the terms and conditions of the most recently dated version of SMSC's standard Terms of Sale Agreement dated before the date of your order (the "Terms of Sale Agreement"). The product may contain design defects or errors known as anomalies which may cause the product's functions to deviate from published specifications. Anomaly sheets are available upon request. SMSC products are not designed, intended, authorized or warranted for use in any life support or other application where product failure could cause or contribute to personal injury or severe property damage. Any and all such uses without prior written approval of an Officer of SMSC and further testing and/or modification will be fully at the risk of the customer. Copies of this document or other SMSC literature, as well as the Terms of Sale Agreement, may be obtained by visiting SMSC's website at <http://www.smisc.com>. SMSC is a registered trademark of Standard Microsystems Corporation ("SMSC"). Product names and company names are the trademarks of their respective holders.

SMSC DISCLAIMS AND EXCLUDES ANY AND ALL WARRANTIES, INCLUDING WITHOUT LIMITATION ANY AND ALL IMPLIED WARRANTIES OF MERCHANTABILITY, FITNESS FOR A PARTICULAR PURPOSE, TITLE, AND AGAINST INFRINGEMENT AND THE LIKE, AND ANY AND ALL WARRANTIES ARISING FROM ANY COURSE OF DEALING OR USAGE OF TRADE. IN NO EVENT SHALL SMSC BE LIABLE FOR ANY DIRECT, INCIDENTAL, INDIRECT, SPECIAL, PUNITIVE, OR CONSEQUENTIAL DAMAGES; OR FOR LOST DATA, PROFITS, SAVINGS OR REVENUES OF ANY KIND; REGARDLESS OF THE FORM OF ACTION, WHETHER BASED ON CONTRACT; TORT; NEGLIGENCE OF SMSC OR OTHERS; STRICT LIABILITY; BREACH OF WARRANTY; OR OTHERWISE; WHETHER OR NOT ANY REMEDY OF BUYER IS HELD TO HAVE FAILED OF ITS ESSENTIAL PURPOSE, AND WHETHER OR NOT SMSC HAS BEEN ADVISED OF THE POSSIBILITY OF SUCH DAMAGES.

Package Outline

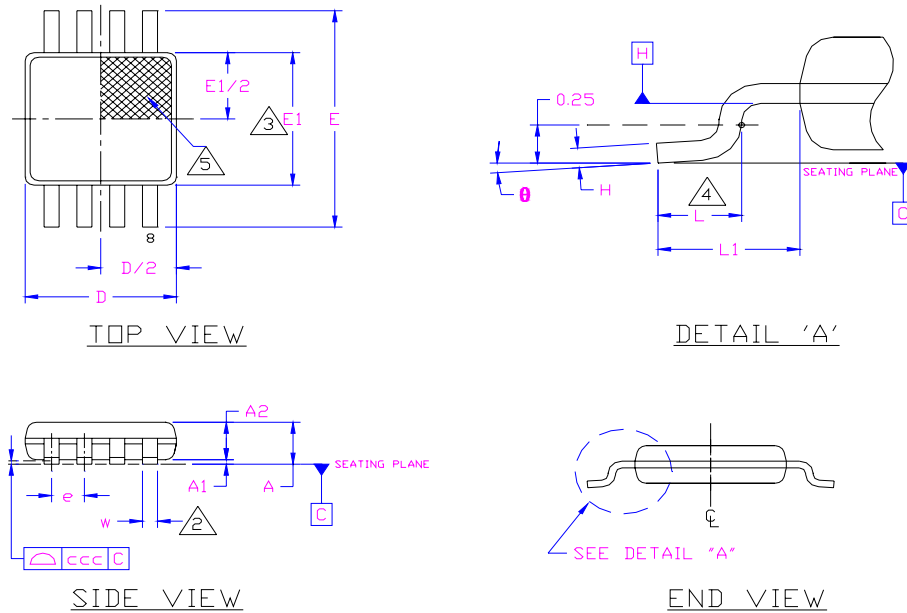

Figure 1 8-Pin MSOP and 8-Pin MSOP (Lead-Free) Package Outline - 3x3mm Body 0.65mm Pitch

Table 1 8-Pin MSOP and 8-Pin MSOP (Lead-Free) Package Parameters

	MIN	NOMINAL	MAX	REMARKS
A	0.80	~	1.10	Overall Package Height
A1	0.05	~	0.15	Standoff
A2	0.75	0.85	0.95	Body Thickness
D	2.80	3.00	3.20	X Body Size
E	4.65	4.90	5.15	Y Span
E1	2.80	~	3.20	Y body Size
H	0.08	~	0.23	Lead Foot Thickness
L	0.40	~	0.80	Lead Foot Length
L1	0.95 REF			Lead Length
e	0.65 BSC			Lead Pitch
θ	0°	~	8°	Lead Foot Angle
W	0.22	~	0.38	Lead Width
ccc	~	~	0.10	Coplanarity

Notes:

- Controlling Unit: millimeters.
- Tolerance on the true position of the leads is ± 0.065 mm maximum.
- Package body dimensions D and E1 do not include mold protrusion or flash. Dimensions D and E1 to be determined at datum plane H. Maximum mold protrusion or flash is 0.15mm (0.006 inches) per end, and 0.15mm (0.006 inches) per side.
- Dimension for foot length L measured at the gauge plane 0.25 mm above the seating plane.
- Details of pin 1 identifier are optional but must be located within the zone indicated.