

Charge Pump DC-TO-DC Voltage Converter

FEATURES

- Converts +5V Logic Supply to $\pm 5V$ System
- Wide Input Voltage Range 1.5V to 12V
- Efficient Voltage Conversion 99.9%
- Excellent Power Efficiency 98%
- Low Power Consumption 80 μ A @ $V_{IN} = 5V$
- Low Cost and Easy to Use
 - Only Two External Capacitors Required
- RS-232 Negative Power Supply
- Available in 8-Pin Small Outline (SOIC) and 8-Pin Plastic DIP Packages
- Improved ESD Protection Up to 10kV
- No External Diode Required for High Voltage Operation
- Frequency Boost Raises F_{OSC} to 45kHz

GENERAL DESCRIPTION

The TC1044S is a pin-compatible upgrade to the Industry standard TC7660 charge pump voltage converter. It converts a +1.5V to +12V input to a corresponding -1.5V to -12V output using only two low cost capacitors, eliminating inductors and their associated cost, size and EMI. Added features include an extended supply range to 12V, and a frequency boost pin for higher operating frequency, allowing the use of smaller external capacitors.

The on-board oscillator operates at a nominal frequency of 10kHz. Frequency is increased to 45kHz when pin 1 is connected to V^+ . Operation below 10kHz (for lower supply current applications) is possible by connecting an external capacitor from OSC to ground (with pin 1 open).

The TC1044S is available in both 8-pin DIP and 8-pin small outline (SOIC) packages in commercial and extended temperature ranges.

PIN CONFIGURATION (DIP AND SOIC)

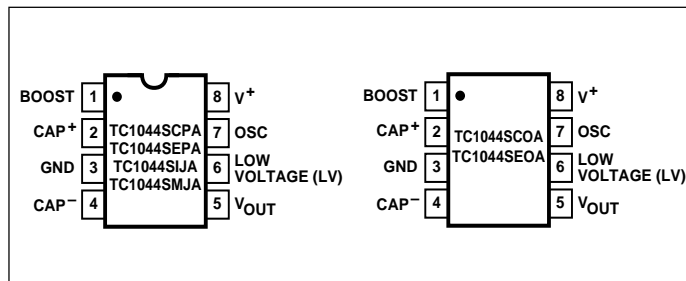

ORDERING INFORMATION

Part No.	Package	Temp. Range
TC1044SCOEA	8-Pin SOIC	0°C to +70°C
TC1044SCPA	8-Pin Plastic DIP	0°C to +70°C
TC1044SEOA	8-Pin SOIC	-40°C to +85°C
TC1044SEPA	8-Pin Plastic DIP	-40°C to +85°C
TC1044SIJA	8-Pin CerDIP	-25°C to +85°C
TC1044SMJA	8-Pin CerDIP	-55°C to +125°C
TC7660EV	Charge Pump Family Evaluation Kit	

FUNCTIONAL BLOCK DIAGRAM

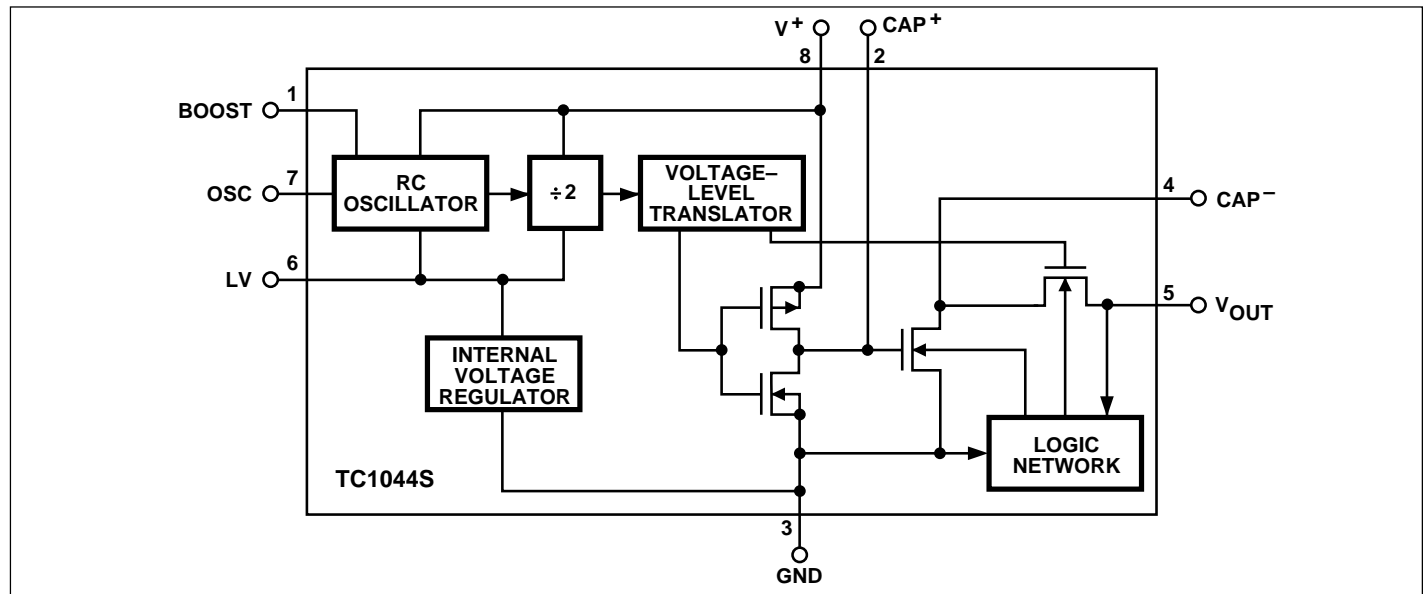

Charge Pump DC-TO-DC Voltage Converter

TC1044S

ABSOLUTE MAXIMUM RATINGS*

Supply Voltage	+13V
LV, Boost and OSC Inputs Voltage (Note 1)	- 0.3V to (V ⁺ + 0.3V) for V ⁺ < 5.5V (V ⁺ - 5.5V) to (V ⁺ + 0.3V) for V ⁺ > 5.5V
Current Into LV (Note 1)	20μA for V ⁺ > 3.5V
Output Short Duration (V _{SUPPLY} ≤ 5.5V)	Continuous
Lead Temperature (Soldering, 10 sec)	+300°C

Package Power Dissipation (T_A ≤ 70°C) (Note 2)

8-Pin CerDIP	800mW
8-Pin Plastic DIP	730mW
8-Pin SOIC	470mW

Operating Temperature Range

C Suffix	0°C to +70°C
I Suffix	- 25°C to +85°C
E Suffix	- 40°C to +85°C
M Suffix	- 55°C to +125°C
Storage Temperature Range	- 65°C to +150°C

*Static-sensitive device. Unused devices must be stored in conductive material. Protect devices from static discharge and static fields. Stresses above those listed under "Absolute Maximum Ratings" may cause permanent damage to the device. These are stress ratings only and functional operation of the device at these or any other conditions above those indicated in the operation sections of the specifications is not implied. Exposure to absolute maximum rating conditions for extended periods may affect device reliability.

ELECTRICAL CHARACTERISTICS: T_A = +25°C, V⁺ = 5V, C_{OSC} = 0, Test Circuit (Figure 1), unless otherwise indicated.

Symbol	Parameter	Test Conditions	Min	Typ	Max	Unit
I ⁺	Supply Current	R _L = ∞ 0°C < T _A < +70°C - 40°C < T _A < +85°C - 55°C < T _A < +125°C	—	80	160	μA
I ⁺	Supply Current (Boost Pin = V ⁺)	0°C < T _A < +70°C - 40°C < T _A < +85°C - 55°C < T _A < +125°C	—	—	300	μA
V _{H2} ⁺	Supply Voltage Range, High	Min ≤ T _A ≤ Max, R _L = 10 kΩ, LV Open	3	—	12	V
V _{L2} ⁺	Supply Voltage Range, Low	Min ≤ T _A ≤ Max, R _L = 10 kΩ, LV to GND	1.5	—	3.5	V
R _{OUT}	Output Source Resistance	I _{OUT} = 20mA I _{OUT} = 20mA, 0°C ≤ T _A ≤ +70°C I _{OUT} = 20mA, -40°C ≤ T _A ≤ +85°C I _{OUT} = 20mA, -55°C ≤ T _A ≤ +125°C	—	60	100	Ω
		V ⁺ = 2V, I _{OUT} = 3 mA, LV to GND	—	70	120	
		0°C ≤ T _A ≤ +70°C	—	70	120	
		- 55°C ≤ T _A ≤ +125°C	—	105	150	
F _{OSC}	Oscillator Frequency	Pin 7 open; Pin 1 open or GND Boost Pin = V ⁺	—	10	—	kHz
			—	45	—	
P _{EFF}	Power Efficiency	R _L = 5 kΩ; Boost Pin Open T _{MIN} < T _A < T _{MAX} ; Boost Pin Open Boost Pin = V ⁺	96	98	—	%
			95	97	—	
			—	88	—	
V _{OUT EFF}	Voltage Conversion Efficiency	R _L = ∞	99	99.9	—	%
Z _{OSC}	Oscillator Impedance	V ⁺ = 2V	—	1	—	MΩ
		V ⁺ = 5V	—	100	—	kΩ

- NOTES:**
1. Connecting any input terminal to voltages greater than V⁺ or less than GND may cause destructive latch-up. It is recommended that no inputs from sources operating from external supplies be applied prior to "power up" of the TC1044S.
 2. Derate linearly above 50°C by 5.5mW/°C.

Circuit Description

The TC1044S contains all the necessary circuitry to implement a voltage inverter, with the exception of two external capacitors, which may be inexpensive 10 μF polarized electrolytic capacitors. Operation is best understood by considering Figure 2, which shows an idealized voltage inverter. Capacitor C_1 is charged to a voltage, V^+ , for the half cycle when switches S_1 and S_3 are closed. (**Note:** Switches S_2 and S_4 are open during this half cycle.) During the second half cycle of operation, switches S_2 and S_4 are closed, with S_1 and S_3 open, thereby shifting capacitor C_1 negatively by V^+ volts. Charge is then transferred from C_1 to C_2 , such that the voltage on C_2 is exactly V^+ , assuming ideal switches and no load on C_2 .

The four switches in Figure 2 are MOS power switches; S_1 is a P-channel device, and S_2 , S_3 and S_4 are N-channel devices. The main difficulty with this approach is that in integrating the switches, the substrates of S_3 and S_4 must always remain reverse-biased with respect to their sources, but not so much as to degrade their ON resistances. In addition, at circuit start-up, and under output short circuit conditions ($V_{\text{OUT}} = V^+$), the output voltage must be sensed and the substrate bias adjusted accordingly. Failure to accomplish this will result in high power losses and probable device latch-up.

This problem is eliminated in the TC1044S by a logic network which senses the output voltage (V_{OUT}) together with the level translators, and switches the substrates of S_3 and S_4 to the correct level to maintain necessary reverse bias.

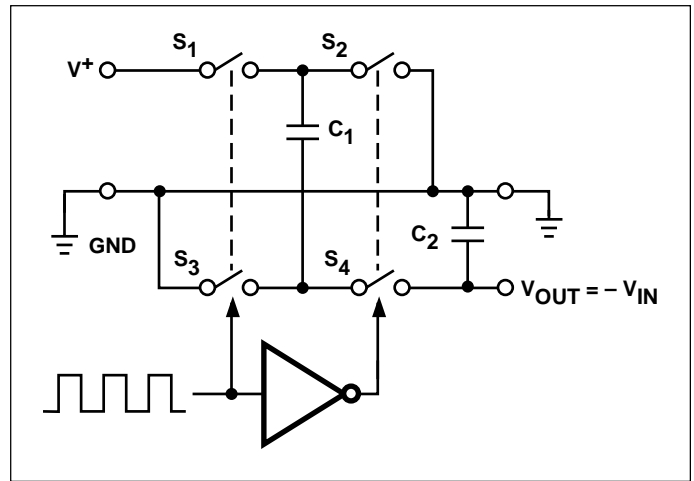

Figure 2. Idealized Charge Pump Inverter

The voltage regulator portion of the TC1044S is an integral part of the anti-latch-up circuitry. Its inherent voltage drop can, however, degrade operation at low voltages. To improve low-voltage operation, the "LV" pin should be connected to GND, disabling the regulator. For supply voltages greater than 3.5V, the LV terminal must be left open to ensure latch-up-proof operation and prevent device damage.

Theoretical Power Efficiency Considerations

In theory, a capacitive charge pump can approach 100% efficiency if certain conditions are met:

- (1) The drive circuitry consumes minimal power.
- (2) The output switches have extremely low ON resistance and virtually no offset.
- (3) The impedances of the pump and reservoir capacitors are negligible at the pump frequency.

The TC1044S approaches these conditions for negative voltage multiplication if large values of C_1 and C_2 are used. **Energy is lost only in the transfer of charge between capacitors if a change in voltage occurs.** The energy lost is defined by:

$$E = 1/2 C_1 (V_1^2 - V_2^2)$$

V_1 and V_2 are the voltages on C_1 during the pump and transfer cycles. If the impedances of C_1 and C_2 are relatively high at the pump frequency (refer to Figure 2) compared to the value of R_L , there will be a substantial difference in voltages V_1 and V_2 . Therefore, it is desirable not only to make C_2 as large as possible to eliminate output voltage ripple, but also to employ a correspondingly large value for C_1 in order to achieve maximum efficiency of operation.

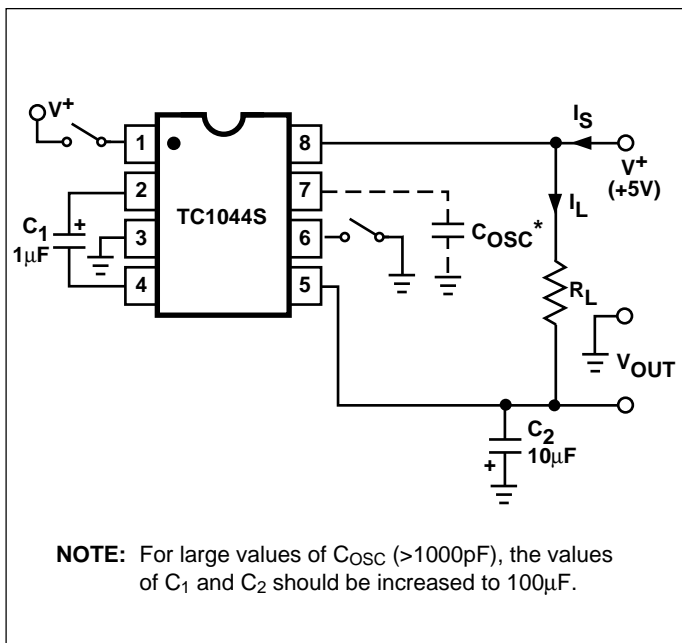

NOTE: For large values of C_{OSC} ($>1000\text{pF}$), the values of C_1 and C_2 should be increased to $100\mu\text{F}$.

Figure 1. TC1044S Test Circuit

TC1044S

Dos and Don'ts

- Do not exceed maximum supply voltages.
- Do not connect the LV terminal to GND for supply voltages greater than 3.5V.
- Do not short circuit the output to V^+ supply for voltages above 5.5V for extended periods; however, transient conditions including start-up are okay.
- When using polarized capacitors in the inverting mode, the + terminal of C_1 must be connected to pin 2 of the TC1044S and the + terminal of C_2 must be connected to GND.

Simple Negative Voltage Converter

Figure 3 shows typical connections to provide a negative supply where a positive supply is available. A similar scheme may be employed for supply voltages anywhere in the operating range of +1.5V to +12V, keeping in mind that pin 6 (LV) is tied to the supply negative (GND) only for supply voltages below 3.5V.

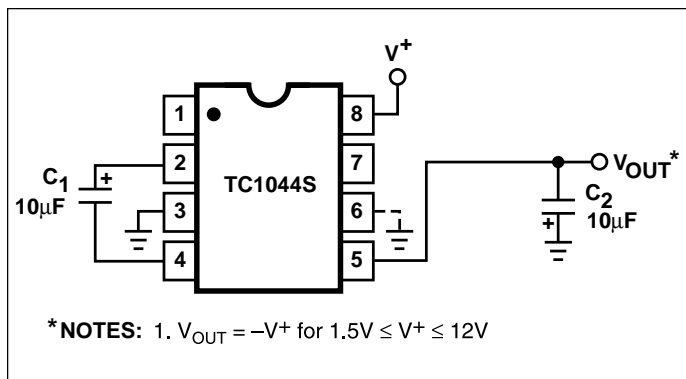

Figure 3. Simple Negative Converter

The output characteristics of the circuit in Figure 3 are those of a nearly ideal voltage source in series with 70Ω . Thus, for a load current of $-10mA$ and a supply voltage of +5V, the output voltage would be $-4.3V$.

The dynamic output impedance of the TC1044S is due, primarily, to capacitive reactance of the charge transfer capacitor (C_1). Since this capacitor is connected to the output for only 1/2 of the cycle, the equation is:

$$X_C = \frac{2}{2\pi f C_1} = 3.18\Omega,$$

where $f = 10 \text{ kHz}$ and $C_1 = 10\mu F$.

Paralleling Devices

Any number of TC1044S voltage converters may be paralleled to reduce output resistance (Figure 4). The reservoir capacitor, C_2 , serves all devices, while each device requires its own pump capacitor, C_1 . The resultant output resistance would be approximately:

$$R_{OUT} = \frac{R_{OUT} \text{ (of TC1044S)}}{n \text{ (number of devices)}}$$

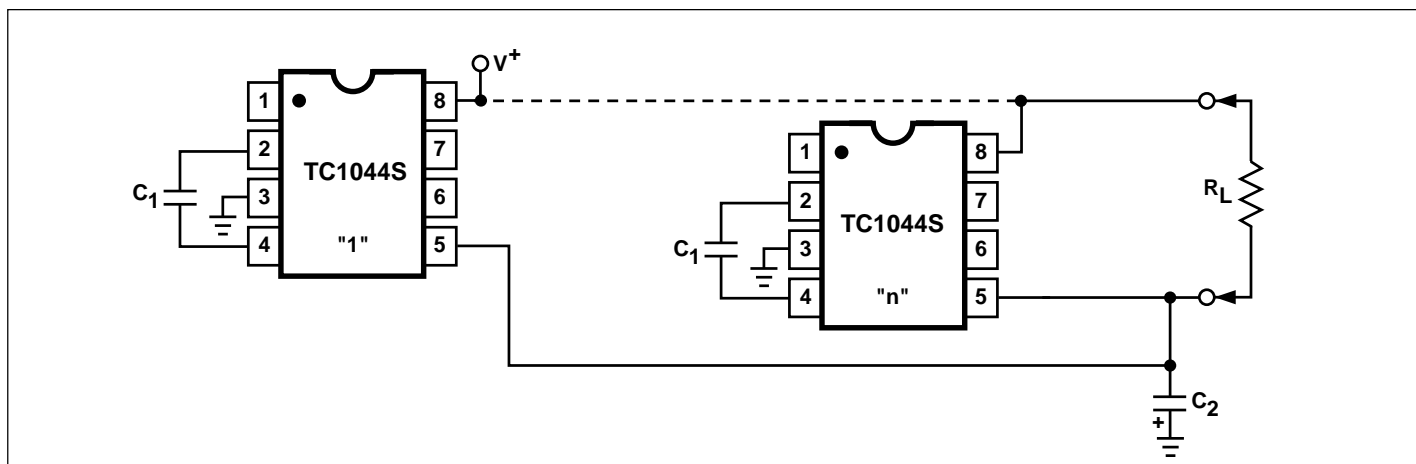

Figure 4. Paralleling Devices Lowers Output Impedance

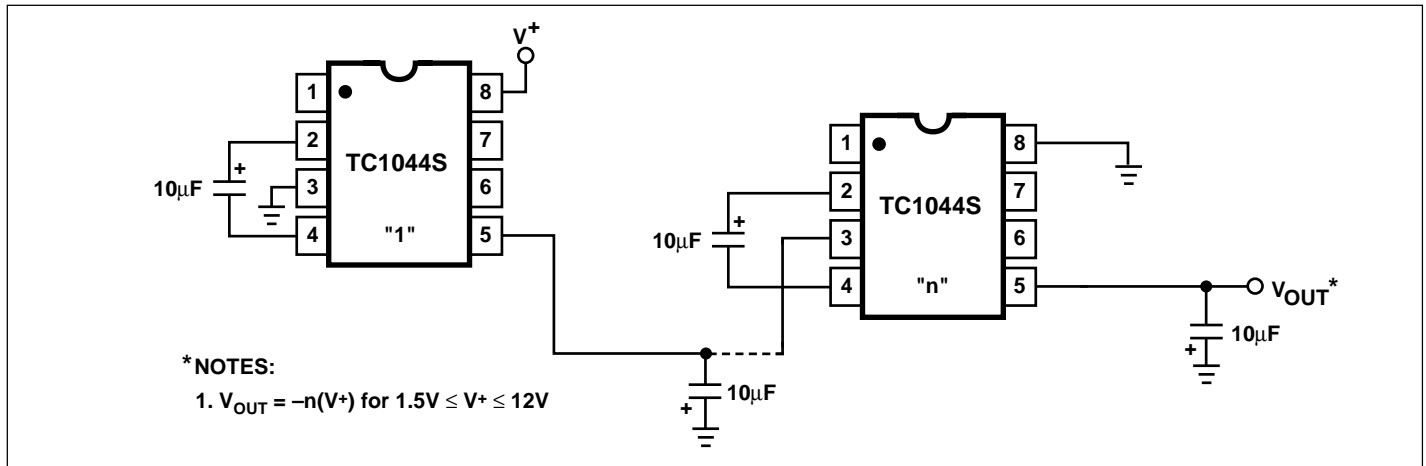

Figure 5. Increased Output Voltage by Cascading Devices

Cascading Devices

The TC1044S may be cascaded as shown (Figure 5) to produce larger negative multiplication of the initial supply voltage. However, due to the finite efficiency of each device, the practical limit is 10 devices for light loads. The output voltage is defined by:

$$V_{OUT} = -n(V_{IN})$$

where n is an integer representing the number of devices cascaded. The resulting output resistance would be approximately the weighted sum of the individual TC1044S R_{OUT} values.

Changing the TC1044S Oscillator Frequency

It may be desirable in some applications (due to noise or other considerations) to increase the oscillator frequency. Pin 1, frequency boost pin may be connected to V^+ to increase oscillator frequency to 45kHz from a nominal of 10kHz for an input supply voltage of 5.0 volts. The oscillator may also be synchronized to an external clock as shown in Figure 6. In order to prevent possible device latch-up, a 1k Ω resistor must be used in series with the clock output. In a

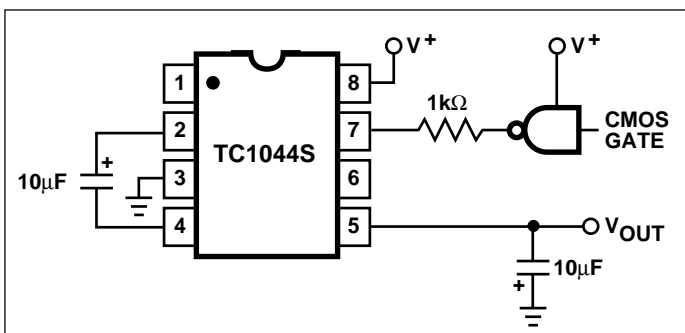

Figure 6. External Clocking

situation where the designer has generated the external clock frequency using TTL logic, the addition of a 10k Ω pull-up resistor to V^+ supply is required. Note that the pump frequency with external clocking, as with internal clocking, will be 1/2 of the clock frequency. Output transitions occur on the positive-going edge of the clock.

It is also possible to increase the conversion efficiency of the TC1044S at low load levels by lowering the oscillator frequency. This reduces the switching losses, and is achieved by connecting an additional capacitor, C_{OSC} , as shown in Figure 7. Lowering the oscillator frequency will cause an undesirable increase in the impedance of the pump (C_1) and the reservoir (C_2) capacitors. To overcome this, increase the values of C_1 and C_2 by the same factor that the frequency has been reduced. For example, the addition of a 100pF capacitor between pin 7 (OSC) and pin 8 (V^+) will lower the oscillator frequency to 1kHz from its nominal frequency of 10kHz (a multiple of 10), and necessitate a corresponding increase in the values of C_1 and C_2 (from 10 μ F to 100 μ F).

Positive Voltage Multiplication

The TC1044S may be employed to achieve positive voltage multiplication using the circuit shown in Figure 8. In this application, the pump inverter switches of the TC1044S are used to charge C_1 to a voltage level of $V^+ - V_F$ (where V^+ is the supply voltage and V_F is the forward voltage drop of diode D_1). On the transfer cycle, the voltage on C_1 plus the supply voltage (V^+) is applied through diode D_2 to capacitor C_2 . The voltage thus created on C_2 becomes $(2V^+) - (2V_F)$, or twice the supply voltage minus the combined forward voltage drops of diodes D_1 and D_2 .

The source impedance of the output (V_{OUT}) will depend on the output current, but for $V^+ = 5V$ and an output current of 10mA, it will be approximately 60 Ω .

TC1044S

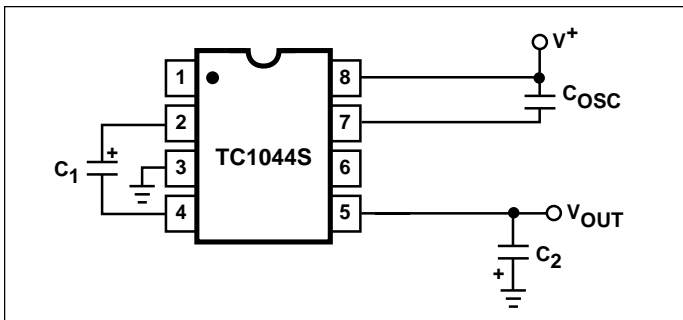

Figure 7. Lowering Oscillator Frequency

Combined Negative Voltage Conversion and Positive Supply Multiplication

Figure 9 combines the functions shown in Figures 3 and 8 to provide negative voltage conversion and positive voltage multiplication simultaneously. This approach would be, for example, suitable for generating +9V and -5V from an existing +5V supply. In this instance, capacitors C_1 and C_3 perform the pump and reservoir functions, respectively, for the generation of the negative voltage, while capacitors C_2 and C_4 are pump and reservoir, respectively, for the multiplied positive voltage. There is a penalty in this configuration which combines both functions, however, in that the source impedances of the generated supplies will be somewhat higher due to the finite impedance of the common charge pump driver at pin 2 of the device.

Efficient Positive Voltage Multiplication/Conversion

Since the switches that allow the charge pumping operation are bidirectional, the charge transfer can be performed backwards as easily as forwards. Figure 10 shows a TC1044S transforming -5V to +5V (or +5V to +10V, etc.). The only problem here is that the internal clock and switch-drive section will not operate until some positive voltage has been generated. An initial inefficient pump, as shown in Figure 9, could be used to start this circuit up, after which it

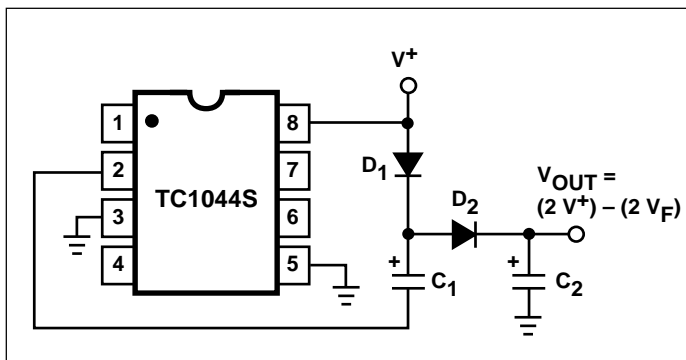

Figure 8. Positive Voltage Multiplier

will bypass the other (D_1 and D_2 in Figure 9 would never turn on), or else the diode and resistor shown dotted in Figure 10 can be used to "force" the internal regulator on.

Voltage Splitting

The same bidirectional characteristics used in Figure 10 can also be used to split a higher supply in half, as shown in Figure 11. The combined load will be evenly shared between the two sides. Once again, a high value resistor to the LV pin ensures start-up. Because the switches share the load in parallel, the output impedance is much lower than in the standard circuits, and higher currents can be drawn from the device. By using this circuit, and then the circuit of Figure 5, +15V can be converted (via +7.5V and -7.5V) to a nominal -15V, though with rather high series resistance (~250Ω).

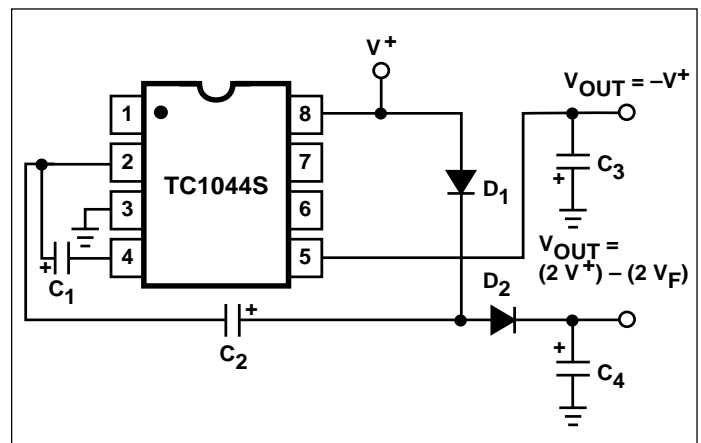

Figure 9. Combined Negative Converter and Positive Multiplier

Negative Voltage Generation for Display ADCs

The TC7106 is designed to work from a 9V battery. With a fixed power supply system, the TC7106 will perform conversions with input signal referenced to power supply ground.

Negative Supply Generation for 4½ Digit Data Acquisition System

The TC7135 is a 4½ digit ADC operating from ±5V supplies. The TC1044S provides an inexpensive -5V source. (See AN16 and AN17 for TC7135 interface details and software routines.)

Charge Pump DC-TO-DC Voltage Converter

TC1044S

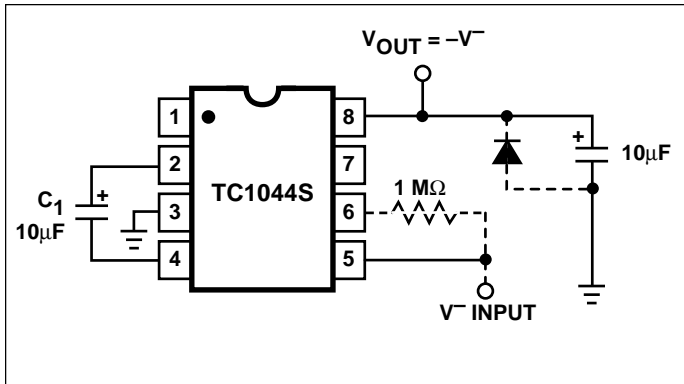

Figure 10. Positive Voltage Conversion

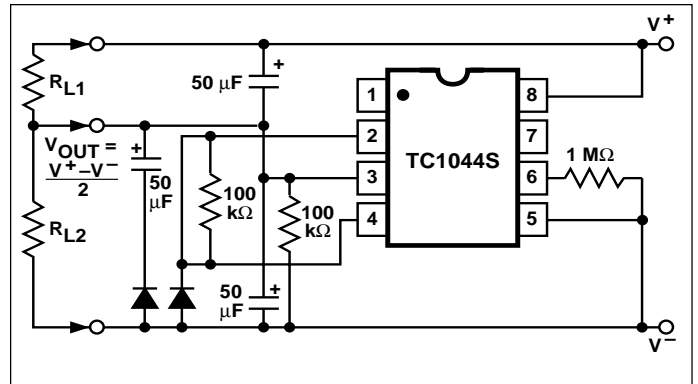
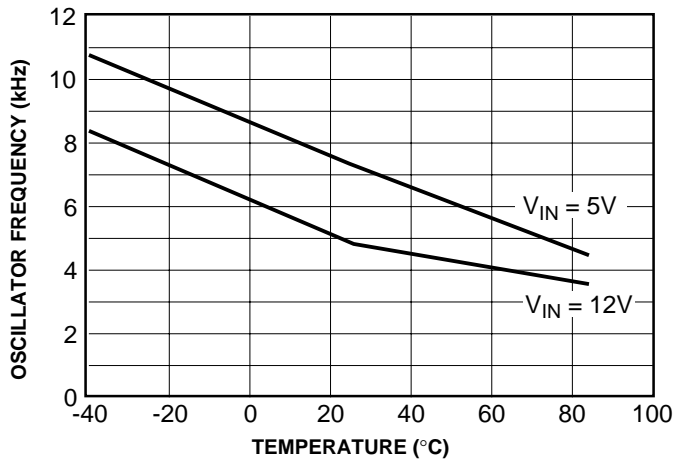

Figure 11. Splitting a Supply in Half

TYPICAL CHARACTERISTICS

Unloaded Osc Freq vs. Temperature



Unloaded Osc Freq vs. Temperature with Boost Pin = V_{IN}

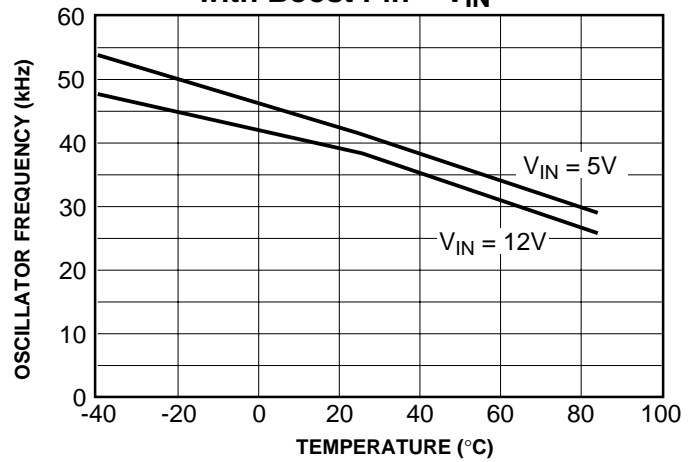

Supply Current vs. Temperature (with Boost Pin = V_{IN})

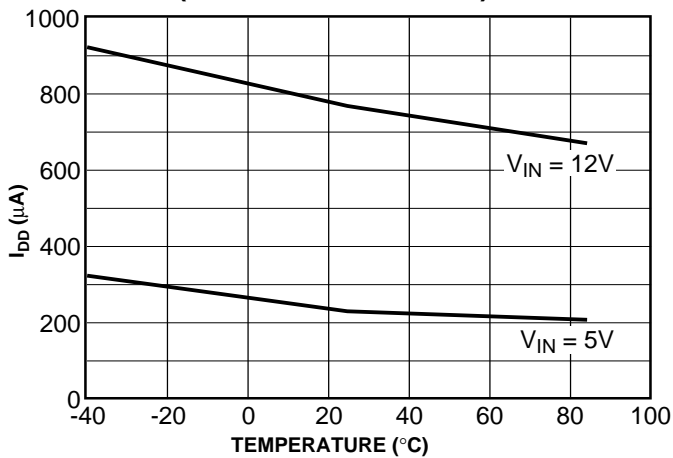

Voltage Conversion

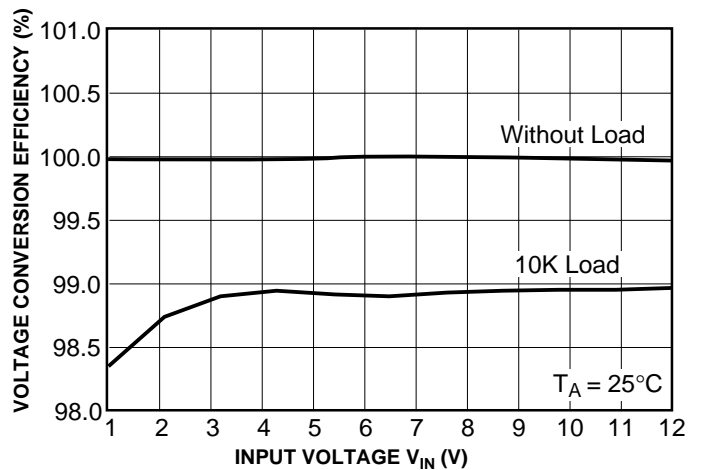

Charge Pump DC-TO-DC Voltage Converter

TC1044S

TYPICAL CHARACTERISTICS (Cont.)

Output Source Resistance vs. Supply Voltage

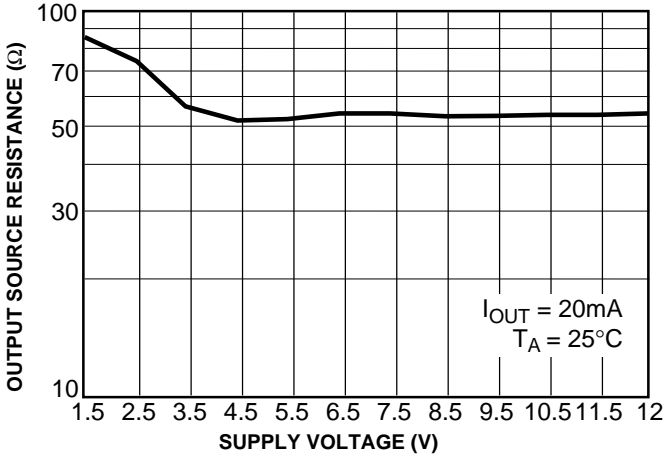

Output Source Resistance vs. Temperature

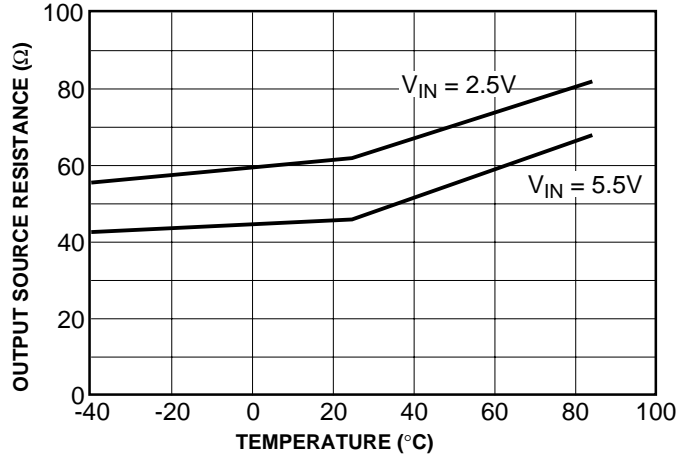

Output Voltage vs. Output Current

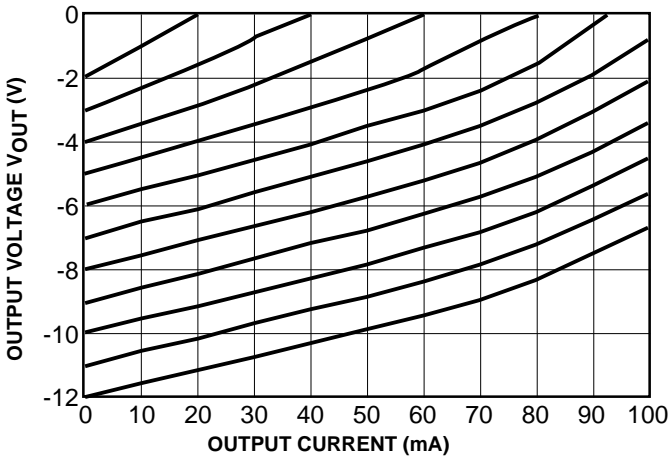

Power Conversion Efficiency vs. Load

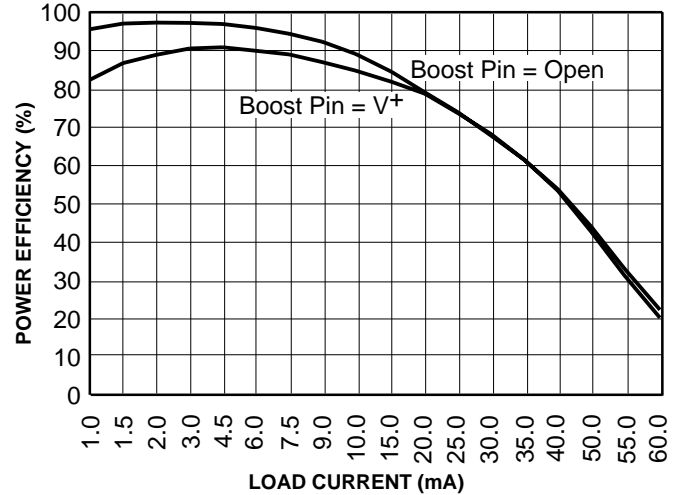

Supply Current vs. Temperature

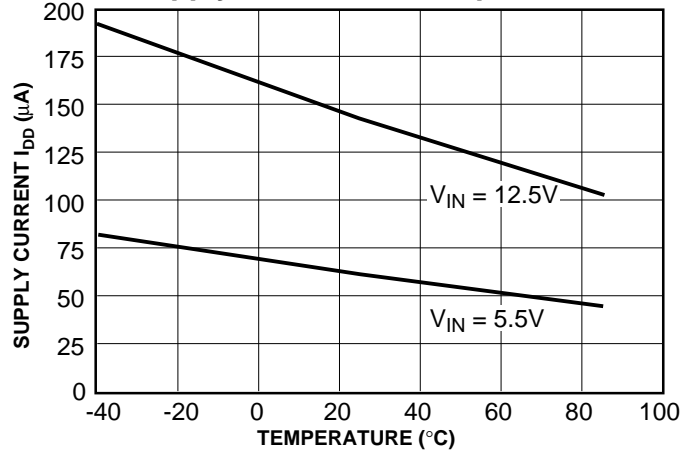

PACKAGE DIMENSIONS

8-Pin Plastic DIP

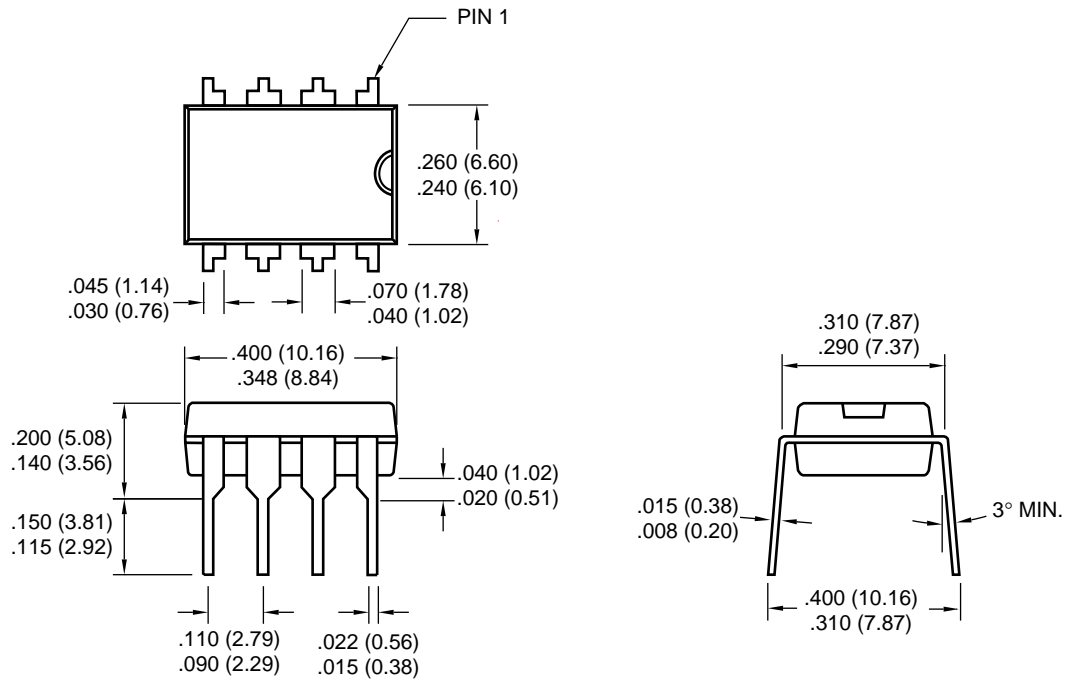

8-Pin CerDIP

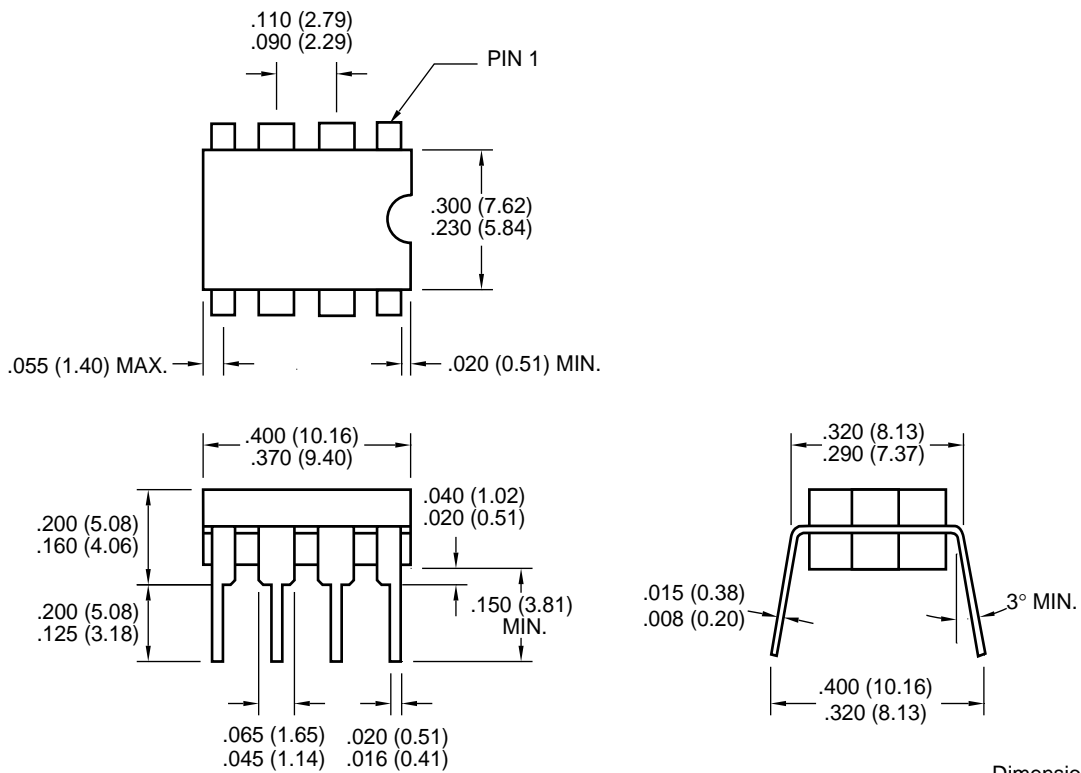

Dimensions: inches (mm)

TC1044S

PACKAGE DIMENSIONS (CONT.)

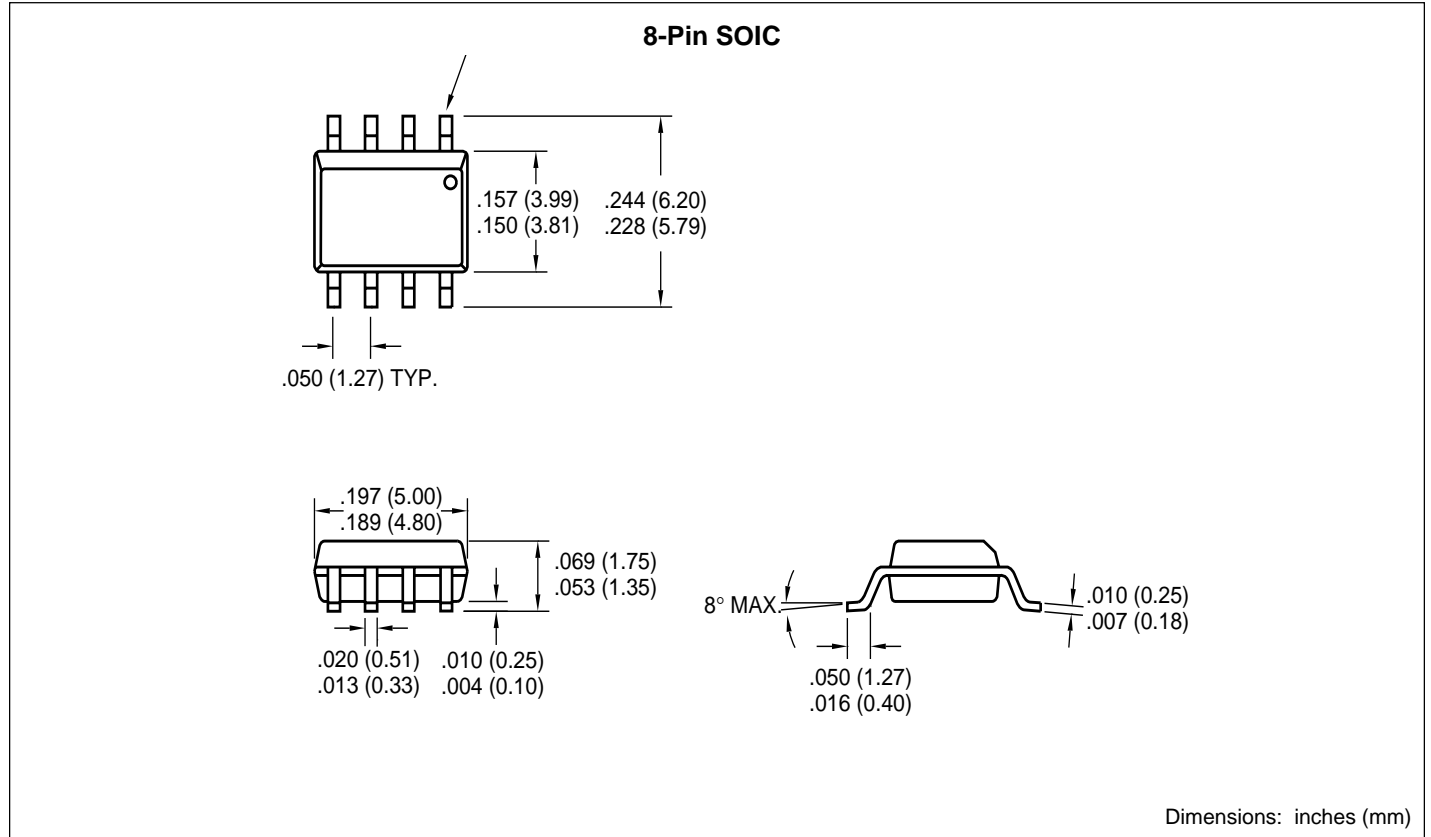



WORLDWIDE SALES AND SERVICE

AMERICAS

Corporate Office

2355 West Chandler Blvd.
Chandler, AZ 85224-6199
Tel: 480-792-7200 Fax: 480-792-7277
Technical Support: 480-792-7627
Web Address: <http://www.microchip.com>

Rocky Mountain

2355 West Chandler Blvd.
Chandler, AZ 85224-6199
Tel: 480-792-7966 Fax: 480-792-7456

Atlanta

500 Sugar Mill Road, Suite 200B
Atlanta, GA 30350
Tel: 770-640-0034 Fax: 770-640-0307

Austin

Analog Product Sales
8303 MoPac Expressway North
Suite A-201
Austin, TX 78759
Tel: 512-345-2030 Fax: 512-345-6085

Boston

2 Lan Drive, Suite 120
Westford, MA 01886
Tel: 978-692-3848 Fax: 978-692-3821

Boston

Analog Product Sales
Unit A-8-1 Millbrook Tarry Condominium
97 Lowell Road
Concord, MA 01742
Tel: 978-371-6400 Fax: 978-371-0050

Chicago

333 Pierce Road, Suite 180
Itasca, IL 60143
Tel: 630-285-0071 Fax: 630-285-0075

Dallas

4570 Westgrove Drive, Suite 160
Addison, TX 75001
Tel: 972-818-7423 Fax: 972-818-2924

Dayton

Two Prestige Place, Suite 130
Miamisburg, OH 45342
Tel: 937-291-1654 Fax: 937-291-9175

Detroit

Tri-Atria Office Building
32255 Northwestern Highway, Suite 190
Farmington Hills, MI 48334
Tel: 248-538-2250 Fax: 248-538-2260

Los Angeles

18201 Von Karman, Suite 1090
Irvine, CA 92612
Tel: 949-263-1888 Fax: 949-263-1338

Mountain View

Analog Product Sales
1300 Terra Bella Avenue
Mountain View, CA 94043-1836
Tel: 650-968-9241 Fax: 650-967-1590

New York

150 Motor Parkway, Suite 202
Hauppauge, NY 11788
Tel: 631-273-5305 Fax: 631-273-5335

San Jose

Microchip Technology Inc.
2107 North First Street, Suite 590
San Jose, CA 95131
Tel: 408-436-7950 Fax: 408-436-7955

Toronto

6285 Northam Drive, Suite 108
Mississauga, Ontario L4V 1X5, Canada
Tel: 905-673-0699 Fax: 905-673-6509

ASIA/PACIFIC

China - Beijing

Microchip Technology Beijing Office
Unit 915
New China Hong Kong Manhattan Bldg.
No. 6 Chaoyangmen Beidajie
Beijing, 100027, No. China
Tel: 86-10-85282100 Fax: 86-10-85282104

China - Shanghai

Microchip Technology Shanghai Office
Room 701, Bldg. B
Far East International Plaza
No. 317 Xian Xia Road
Shanghai, 200051
Tel: 86-21-6275-5700 Fax: 86-21-6275-5060

Hong Kong

Microchip Asia Pacific
RM 2101, Tower 2, Metroplaza
223 Hing Fong Road
Kwai Fong, N.T., Hong Kong
Tel: 852-2401-1200 Fax: 852-2401-3431

India

Microchip Technology Inc.
India Liaison Office
Divyasree Chambers
1 Floor, Wing A (A3/A4)
No. 11, O'Shaughnessy Road
Bangalore, 560 025, India
Tel: 91-80-2290061 Fax: 91-80-2290062

Japan

Microchip Technology Intl. Inc.
Benex S-1 6F
3-18-20, Shinyokohama
Kohoku-Ku, Yokohama-shi
Kanagawa, 222-0033, Japan
Tel: 81-45-471- 6166 Fax: 81-45-471-6122

Korea

Microchip Technology Korea
168-1, Youngbo Bldg. 3 Floor
Samsung-Dong, Kangnam-Ku
Seoul, Korea
Tel: 82-2-554-7200 Fax: 82-2-558-5934

ASIA/PACIFIC (continued)

Singapore

Microchip Technology Singapore Pte Ltd.
200 Middle Road
#07-02 Prime Centre
Singapore, 188980
Tel: 65-334-8870 Fax: 65-334-8850

Taiwan

Microchip Technology Taiwan
11F-3, No. 207
Tung Hua North Road
Taipei, 105, Taiwan
Tel: 886-2-2717-7175 Fax: 886-2-2545-0139

EUROPE

Australia

Microchip Technology Australia Pty Ltd
Suite 22, 41 Rawson Street
Epping 2121, NSW
Australia
Tel: 61-2-9868-6733 Fax: 61-2-9868-6755

Denmark

Microchip Technology Denmark ApS
Regus Business Centre
Lautrup høj 1-3
Ballerup DK-2750 Denmark
Tel: 45 4420 9895 Fax: 45 4420 9910

France

Arizona Microchip Technology SARM
Parc d'Activite du Moulin de Massy
43 Rue du Saule Trapu
Batiment A - ler Etage
91300 Massy, France
Tel: 33-1-69-53-63-20 Fax: 33-1-69-30-90-79

Germany

Arizona Microchip Technology GmbH
Gustav-Heinemann Ring 125
D-81739 Munich, Germany
Tel: 49-89-627-144 0 Fax: 49-89-627-144-44

Germany

Analog Product Sales
Lochhamer Strasse 13
D-82152 Martinsried, Germany
Tel: 49-89-895650-0 Fax: 49-89-895650-22

Italy

Arizona Microchip Technology SRL
Centro Direzionale Colleoni
Palazzo Taurus 1 V. Le Colleoni 1
20041 Agrate Brianza
Milan, Italy
Tel: 39-039-65791-1 Fax: 39-039-6899883

United Kingdom

Arizona Microchip Technology Ltd.
505 Eskdale Road
Winnersh Triangle
Wokingham
Berkshire, England RG41 5TU
Tel: 44 118 921 5869 Fax: 44-118 921-5820

All rights reserved. © 2001 Microchip Technology Incorporated. Printed in the USA. 1/01  Printed on recycled paper.

01/09/01

Information contained in this publication regarding device applications and the like is intended through suggestion only and may be superseded by updates. It is your responsibility to ensure that your application meets with your specifications. No representation or warranty is given and no liability is assumed by Microchip Technology Incorporated with respect to the accuracy or use of such information, or infringement of patents or other intellectual property rights arising from such use or otherwise. Use of Microchip's products as critical components in life support systems is not authorized except with express written approval by Microchip. No licenses are conveyed, implicitly or otherwise, except as maybe explicitly expressed herein, under any intellectual property rights. The Microchip logo and name are registered trademarks of Microchip Technology Inc. in the U.S.A. and other countries. All rights reserved. All other trademarks mentioned herein are the property of their respective companies.