

---

## Features

- Interval Pause: 4s to 20s
- After-wiping Time: 2s to 20s
- Wiper Motor's Park Switch
- Wipe/Wash Mode Priority
- One External Capacitor Determines All Time Sequences
- Relay Driver with Z-diode
- Interference Protection According to VDE 0839 or ISO/TR 7637/1
- Load-dump Protected

### 1. Description

The U642B is a bi-polar integrated circuit designed for the wiper application in the automotive market. It includes wipe, wash and interval mode.

### 2. Functional Description

As a convenience feature of the windshield wiper, intermittent and wipe/wash operation functions are implemented in most of the automobiles. The U642B is a cost-effective solution for an accurate timing function control. Wipe/wash mode has priority over interval mode. Interval pause and after-wiping time can be set to fixed values by using resistors in a broad time range. Added value can be provided with an individual, continuous adjustment of the interval pause by a potentiometer which may be built into the stalk. For proper operation, it is mandatory to feed the signal of the wiper motor's park switch into U642B.



---

## Interval and Wipe/Wash Wiper Control IC

---

### U642B

4774C-AUTO-10/07



Figure 2-1. Block Diagram

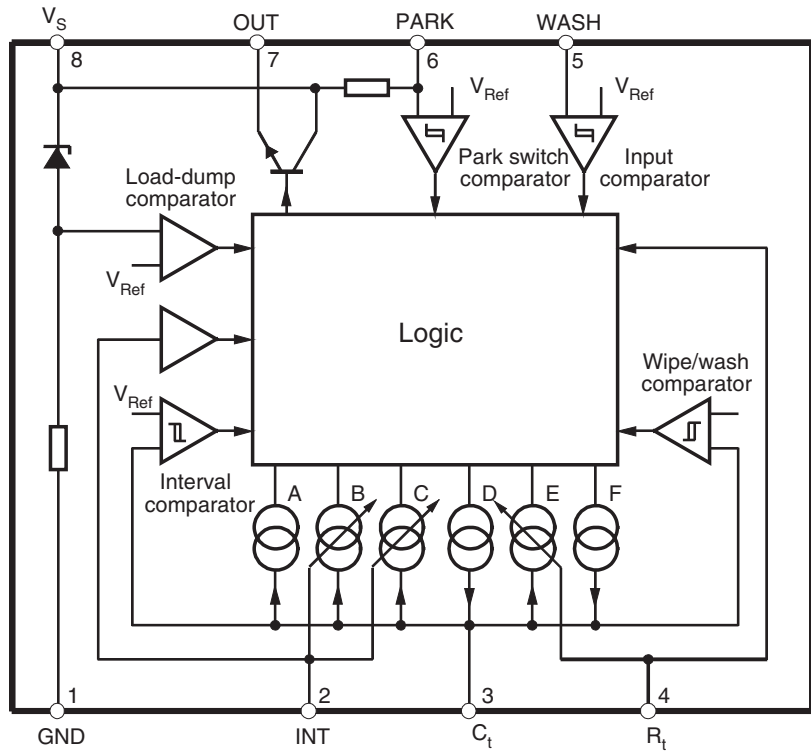

### 3. Pin Configuration

Figure 3-1. Pinning

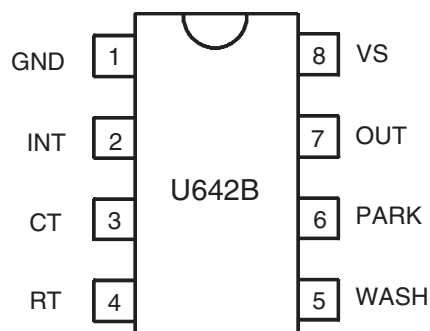

Table 3-1. Pin Description

Pin	Symbol	Function
1	GND	Ground
2	INT	Interval switch
3	CT	Timing capacitor C <sub>2</sub>
4	RT	After-wiping time resistance
5	WASH	Wipe/wash switch
6	PARK	Park switch for wiper motor
7	OUT	Relay control output
8	VS	Supply voltage terminal 15

## 4. Circuit Description

### 4.1 Interval Function, Pin 2

By closing the interval switch,  $S_2$ , to supply voltage,  $V_{Batt}$ , the relay is activated. The internal current source (pin 3) which holds the capacitor  $C_2$  in a charged state is switched-off. As soon as there is a positive potential at the park switch ( $S_1$ ), the current source F (see [Figure 2-1 on page 2](#)) charges the capacitor  $C_2$  very quickly. After the wiper operation is finished,  $S_1$  is again at ground potential, the relay is in the off position - interval pause begins - the capacitor  $C_2$  is discharged through the current source C, till the voltage at pin 3 is below the threshold of 2V. Interval pause can be adjusted between 4s to 20s with the help of potentiometer  $R_3$ . Now the relay switches on and the next interval cycle begins. Opening of switch  $S_2$  causes the current source A to discharge  $C_2$  immediately and current sources C and F are switched-off.

### 4.2 Wipe/Wash (WIWA) Operation, Pin 5

By closing the WIWA switch,  $S_3$ , to supply voltage,  $V_{Batt}$ , the water pump starts spraying water on the windshield. During this function, the current source A is switched-off which keeps the capacitor  $C_2$  in a discharged state. Now the capacitor is charged through the current sources D and F. If (after a time interval of approximately 100 ms) the voltage at the capacitor is greater than 6.5V, the relay is turned on as long as the switch WIWA is closed.

The after-wiping time begins when the switch is open, the sources D and F are switched off and the source E is activated. Source E discharges the capacitor until the voltage is less than 2.2V. The relay is off and the wiper-motor is supplied via the park switch until the park position is reached. The after-wiping time is determined by the current source E which can be regulated with the external resistor  $R_{Time}$ . When the after-wiping time has elapsed, the source A discharges the capacitor. The relay switch is independent of the park switch  $S_1$ .

### 4.3 Interval and WIWA Functions

The interval function is interrupted immediately when the wipe/wash mode is activated. The current source A discharges the capacitor to a value of 2V, afterwards, the normal wash function starts.

Interval wiping starts immediately when the after-wipe time is over. The switching delays are slightly shorter, because the capacitor is already charged to a value of 2V.

The wipe/wash function is not interrupted when the interval switch  $S_2$  is activated. The interval function begins after the WIWA function has elapsed.

Figure 4-1. Application Circuit with Interval and Wipe/Wash Operation

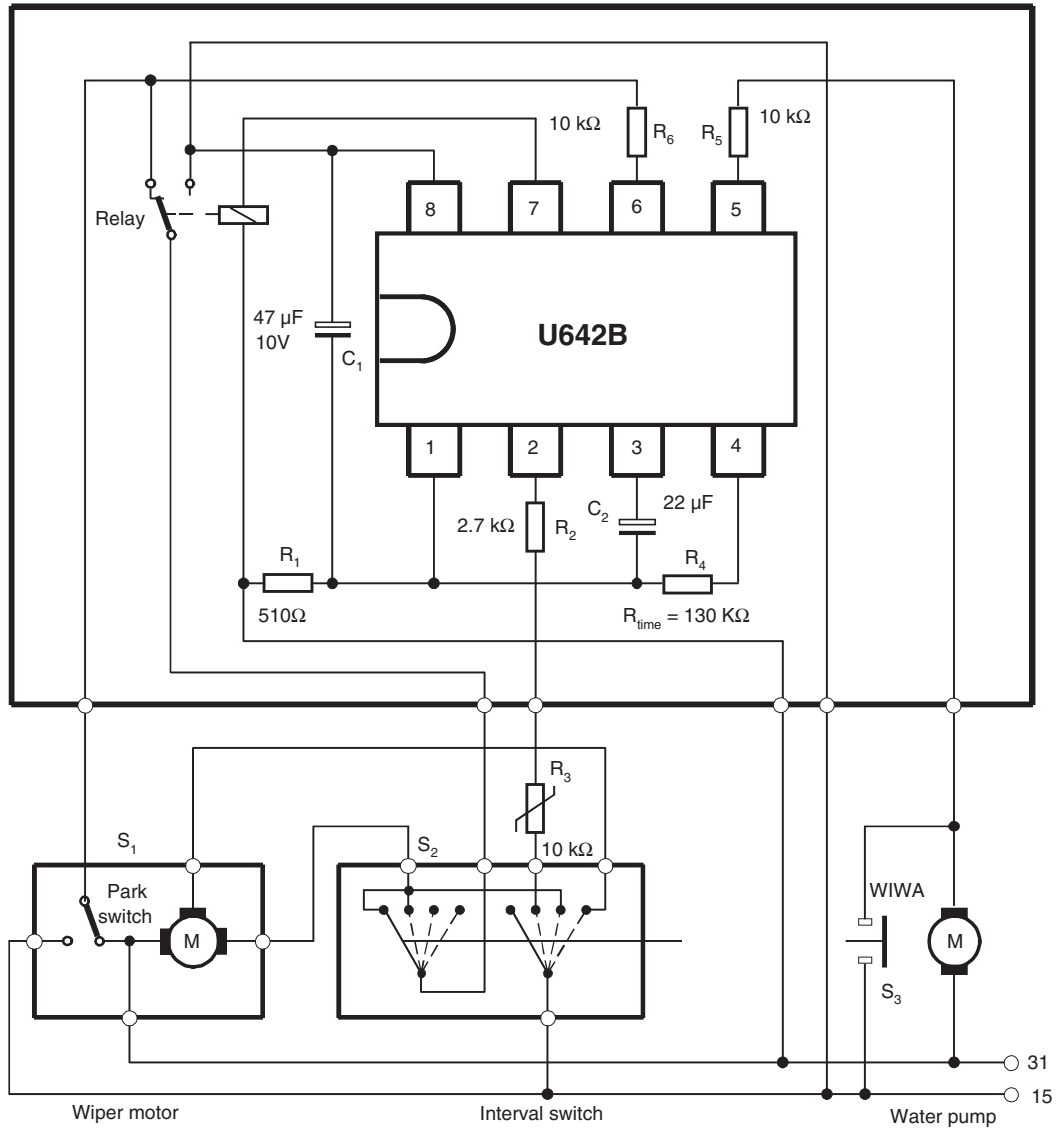



## 5. Absolute Maximum Ratings

Stresses beyond those listed under “Absolute Maximum Ratings” may cause permanent damage to the device. This is a stress rating only and functional operation of the device at these or any other conditions beyond those indicated in the operational sections of this specification is not implied. Exposure to absolute maximum rating conditions for extended periods may affect device reliability.

Parameters	Pin	Symbol	Value	Unit
Supply voltage t = 60s, terminal 15	8	$V_{Batt}$	28	V
Supply current t = 2 ms	8	$I_8$	1.5	A
t = 200 ms		$I_8$	150	mA
Relay control output current (DC)	7	$I_7$	200	mA
t = 200 ms		$I_7$	1.2	A
<b>Pulse Current (Control Inputs) t = 200 ms</b>				
Park switch, $S_1$	6	$I_6$	50	mA
Wipe/Wash switch, $S_3$	5	$I_5$	50	
Interval switch, $S_2$	2	$I_2$	50	
Power dissipation $T_{amb} = 90^\circ\text{C}$		$P_{tot}$	500	mW
Storage temperature range		$T_{stg}$	-55 to +125	$^\circ\text{C}$
Ambient temperature range		$T_{amb}$	-40 to +85	$^\circ\text{C}$

## 6. Thermal Resistance

Parameters		Symbol	Value	Unit
Junction ambient	DIP8	$R_{thJA}$	120	K/W
	SO8	$R_{thJA}$	160	K/W

## 7. Electrical Characteristics

$V_{Batt} = 12V$ ,  $T_{amb} = 25^{\circ}C$ , reference point is pin 8 (see [Figure 4-1 on page 5](#)) unless otherwise specified.

Parameters	Test Conditions	Pin	Symbol	Min.	Typ.	Max.	Unit
Supply voltage		8	$V_{Batt}$	9		16.5	V
Supply current			$I_8$		10		mA
Z-diode limitation			$V_1$		7.6		V
<b>Overvoltage</b>							
Threshold current			$I_1$		-50		mA
Threshold voltage			$V_{Batt}$		35		V
<b>Relay Control Output</b>		7					
Saturation voltage	$I_7 = 100\text{ mA}$ $I_7 = 200\text{ mA}$		$V_7$			-1.0 -1.5	V
Leakage current			$I_7$		100		$\mu A$
<b>Park Switch</b>		6					
Internal pull-up resistance	$R_6 = 10\text{ k}\Omega$		$R_6$		50		$k\Omega$
Switching threshold voltage			$V_6$		-3.3		V
Protection diode	$I_6 = -10\text{ mA}$ $I_6 = 10\text{ mA}$		$V_6$		-0.8		V
			$V_6$		7.6		V
<b>Input C<sub>t</sub></b>		3					
Internal resistance			$R_3$		100		$\Omega$
<b>Interval Input</b>		$R_2 = 2.7\text{ to }30\text{ k}\Omega$ 2					
Protection diode	$I_2 = -10\text{ mA}$ $I_2 = 30\text{ mA}/10\text{ ms}$		$V_2$		-0.8 7.6		V
<b>WASH Input</b>		$R_5 = 10\text{ k}\Omega$ 5					
Switching threshold/ Hysteresis			$V_5$		-1.4/ -5.4		V
Protection diode	$I_5 = -10\text{ mA}$ $I_5 = 10\text{ mA}$		V		-0.8 7.6		V
<b>Switching Characteristics</b>		$R_4 = 47\text{ k}\Omega\text{ to }300\text{ k}\Omega$ , $I_4 = -150\text{ }\mu A$					
Interval time	$R_3 = 0\text{ k}\Omega$ $R_3 = 10\text{ k}\Omega$		$t_2$	3.6 10.8	4 12	4.4 13.2	s
Prewash delay			$t_{del}$		100		ms
After-wipe-time	$R_4 = 130\text{ k}\Omega$	5	$t_5$	4.75	5.25	5.75	s

## 8. Diagrams

**Figure 8-1.** Interval Pause =  $f(T)$ ;  $C_t = 22 \mu\text{F}$

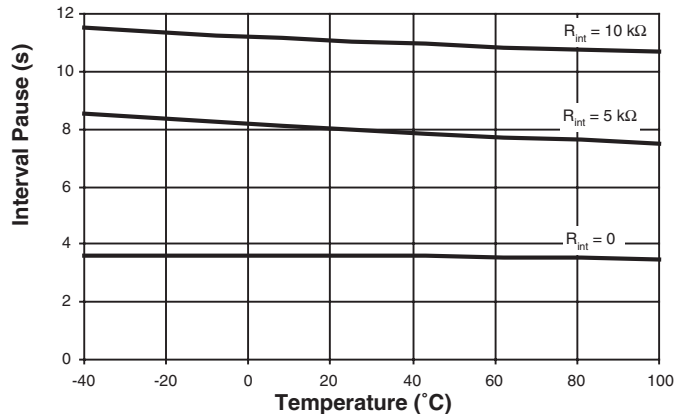

**Figure 8-2.** After-wiping Time =  $f(T)$ ;  $C_t = 22 \mu\text{F}$ ;  $V_{Batt} = 8\text{V}$

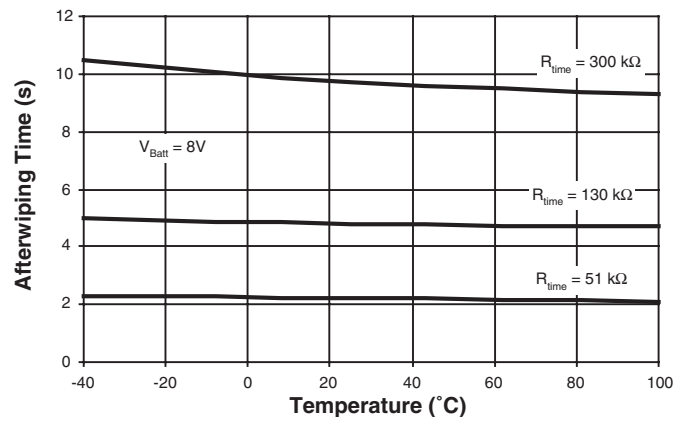

**Figure 8-3.** Interval Pause =  $f(R_{INT})$ ;  $C_t = 22 \mu\text{F}$

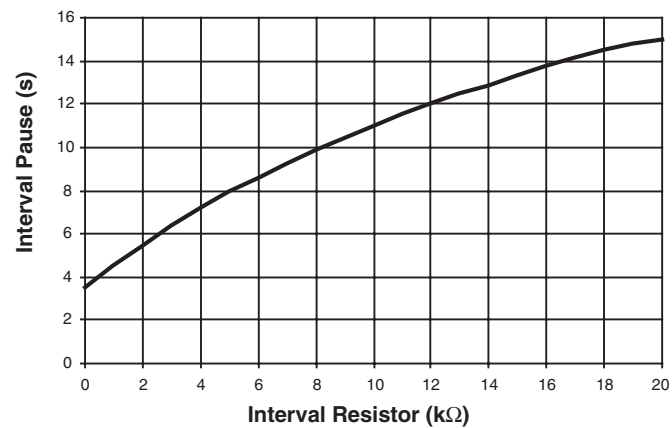
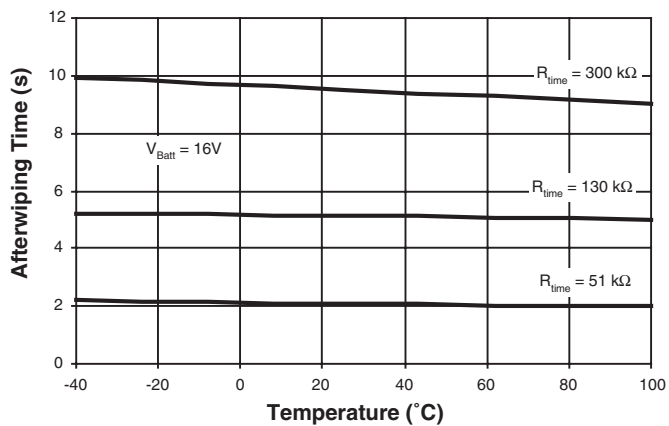



Figure 8-4. After-wiping Time = f (T);  $C_t = 22 \mu\text{F}$ ;  $V_{\text{Batt}} = 16\text{V}$



## 9. Ordering Information

Extended Type Number	Package	Remarks
U642B-MY	DIP8	Pb-free
U642B-MFPY	SO8	Tubed, Pb-free
U642B-MFPG3Y	SO8	Taped and reeled

## 10. Package Information

Package: DIP8  
Dimensions in mm

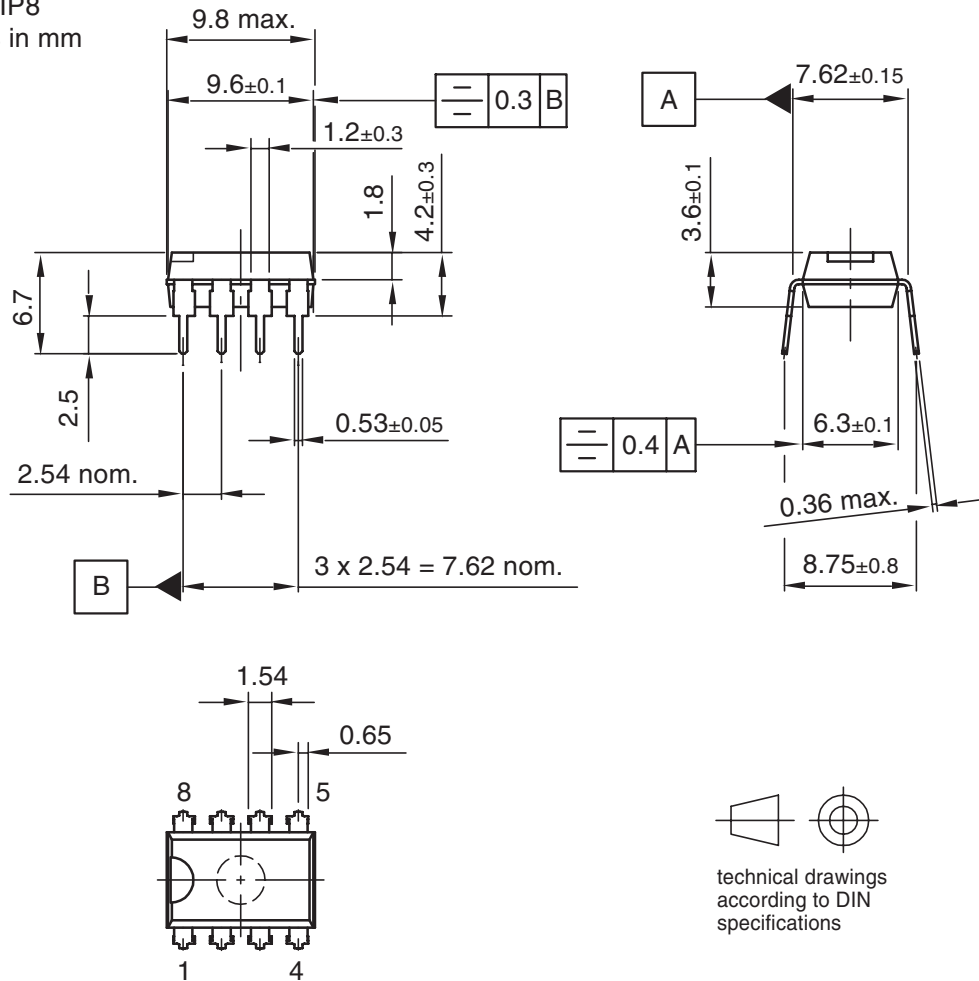

Drawing-No.: 6.543-5040.01-4

Issue: 1; 16.01.02

Package: SO 8

Dimensions in mm

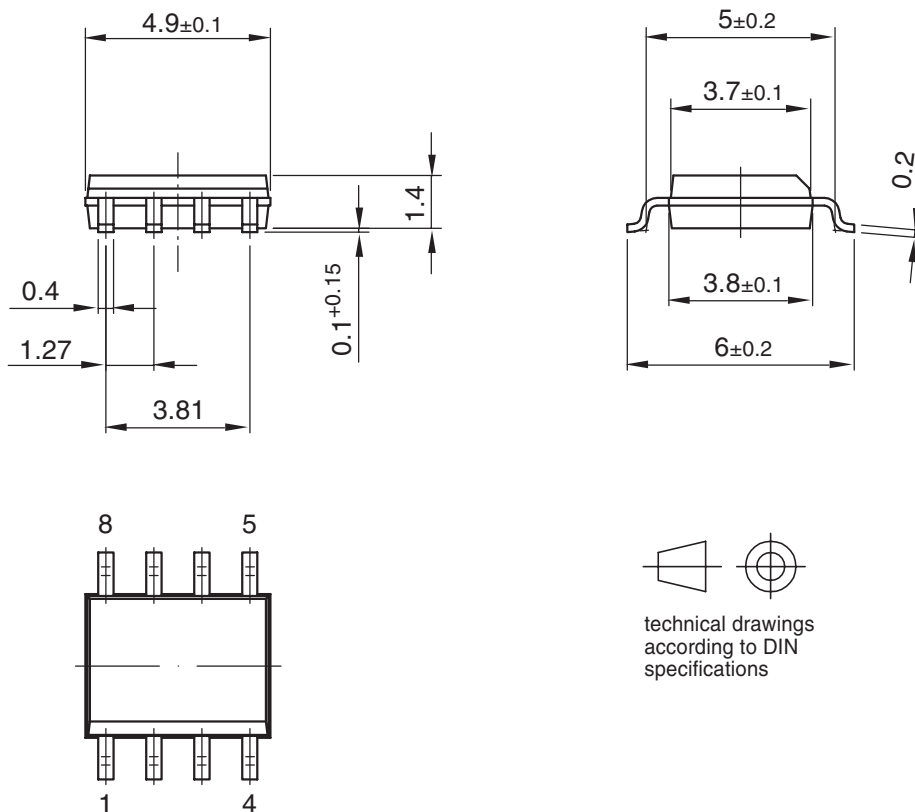

Drawing-No.: 6.541-5031.01-4

Issue: 1; 15.08.06

## 11. Revision History

Please note that the following page numbers referred to in this section refer to the specific revision mentioned, not to this document.

Revision No.	History
4774C-AUTO-09/07	<ul style="list-style-type: none"> <li>Put datasheet in a new template</li> <li>Pb-free logo on page 1 deleted</li> <li>Figure 8-1 "Interval Pause = f (T); <math>C_t = 22 \mu\text{F}</math>" on page 8 changed</li> <li>Figure 8-2 "After-wiping Time = f (T); <math>C_t = 22 \mu\text{F}</math>; <math>V_{\text{Batt}} = 8\text{V}</math>" on page 8 changed</li> <li>Figure 8-4 "After-wiping Time = f (T); <math>C_t = 22 \mu\text{F}</math>; <math>V_{\text{Batt}} = 16\text{V}</math>" on page 9 changed</li> </ul>
4774B-AUTO-09/05	<ul style="list-style-type: none"> <li>Put datasheet in a new template</li> <li>Pb-free logo on page 1 added</li> <li>Ordering Information on page 10 changed</li> </ul>



## Headquarters

---

**Atmel Corporation**  
2325 Orchard Parkway  
San Jose, CA 95131  
USA  
Tel: 1(408) 441-0311  
Fax: 1(408) 487-2600

## International

---

**Atmel Asia**  
Room 1219  
Chinachem Golden Plaza  
77 Mody Road Tsimshatsui  
East Kowloon  
Hong Kong  
Tel: (852) 2721-9778  
Fax: (852) 2722-1369

**Atmel Europe**  
Le Krebs  
8, Rue Jean-Pierre Timbaud  
BP 309  
78054  
Saint-Quentin-en-Yvelines Cedex  
France  
Tel: (33) 1-30-60-70-00  
Fax: (33) 1-30-60-71-11

**Atmel Japan**  
9F, Tonetsu Shinkawa Bldg.  
1-24-8 Shinkawa  
Chuo-ku, Tokyo 104-0033  
Japan  
Tel: (81) 3-3523-3551  
Fax: (81) 3-3523-7581

## Product Contact

---

**Web Site**  
[www.atmel.com](http://www.atmel.com)

**Technical Support**  
[auto\\_control@atmel.com](mailto:auto_control@atmel.com)

**Sales Contact**  
[www.atmel.com/contacts](http://www.atmel.com/contacts)

**Literature Requests**  
[www.atmel.com/literature](http://www.atmel.com/literature)

---

**Disclaimer:** The information in this document is provided in connection with Atmel products. No license, express or implied, by estoppel or otherwise, to any intellectual property right is granted by this document or in connection with the sale of Atmel products. **EXCEPT AS SET FORTH IN ATMEL'S TERMS AND CONDITIONS OF SALE LOCATED ON ATMEL'S WEB SITE, ATMEL ASSUMES NO LIABILITY WHATSOEVER AND DISCLAIMS ANY EXPRESS, IMPLIED OR STATUTORY WARRANTY RELATING TO ITS PRODUCTS INCLUDING, BUT NOT LIMITED TO, THE IMPLIED WARRANTY OF MERCHANTABILITY, FITNESS FOR A PARTICULAR PURPOSE, OR NON-INFRINGEMENT. IN NO EVENT SHALL ATMEL BE LIABLE FOR ANY DIRECT, INDIRECT, CONSEQUENTIAL, PUNITIVE, SPECIAL OR INCIDENTAL DAMAGES (INCLUDING, WITHOUT LIMITATION, DAMAGES FOR LOSS OF PROFITS, BUSINESS INTERRUPTION, OR LOSS OF INFORMATION) ARISING OUT OF THE USE OR INABILITY TO USE THIS DOCUMENT, EVEN IF ATMEL HAS BEEN ADVISED OF THE POSSIBILITY OF SUCH DAMAGES.** Atmel makes no representations or warranties with respect to the accuracy or completeness of the contents of this document and reserves the right to make changes to specifications and product descriptions at any time without notice. Atmel does not make any commitment to update the information contained herein. Unless specifically provided otherwise, Atmel products are not suitable for, and shall not be used in, automotive applications. Atmel's products are not intended, authorized, or warranted for use as components in applications intended to support or sustain life.

© 2007 Atmel Corporation. All rights reserved. Atmel®, logo and combinations thereof, and others are registered trademarks or trademarks of Atmel Corporation or its subsidiaries. Other terms and product names may be trademarks of others.