

## 10G Multi-Protocol Multi-Rate Metro Data Services Media Access Controller (MAC)

The VSC7331VH is an essential component enabling cost-effective, new-generation, metropolitan network markets

- Business Continuance Networks
- Terrestrial Broadcast Networks
- Metro Virtual Private Networks

When used with the VSC9118, the VSC7331 creates a powerful solution for a Universal Line Card that leverages advances in SONET/SDH networks for Metro Area Networks. The VSC7331 makes optimal use of the Virtual Concatenation and LCAS capabilities provided in the VSC9118 to facilitate optimum bandwidth utilization.

Because each port can be independently configured for any of the supported protocols in the Universal Line Card (10/100/1000 Mbps Ethernet, Fibre Channel, FICON, ESCON or DVBASI), Carriers and Services Providers do not have to stock multiple versions of this line card. Such flexibility is central to offering cost-effective solutions for Carriers and Service Providers ensuring competitive deployment of technical and financial resources.

The Vitesse Mapper and MAC components come together seamlessly to offer an optimal solution for cost-effective development of applications addressing high-density, flexible, client interfaces through OC-192 SONET/SDH connectivity with STS-1 granularity. The intelligence and flexibility of the VSC7331VH make it a central building block for metro data services equipment and networks.

The Vitesse VSC7331 is a 10-Gigabit, Multi-Protocol, Multi-Rate Metro Data Services Media Access Controller (MAC). Each port can be independently configured to support any of the supported data streams, including, Ethernet (10/100/1000 Mbps), Fibre Channel (1-Gigabit), FICON, ESCON or DVB-ASI. Alternatively, the VSC7331 can be configured for a single 10- Gigabit Ethernet port.

Line interfaces include Ethernet SERDES, TBI, RGMII, MII or XAU1. The Data Interface is an OIF Standard SPI-4.2 10-Gigabit, multi-channel interface. Key features include Metro Area Flow Control and Advanced Port Aggregation.

### APPLICATIONS

- Universal line card for multi-service provisioning platforms and SONET/SDH add-drop muxes providing 10/100/1000 Mbps Ethernet, Fibre Channel, FICON, ESCON and DVB-ASI
- Link aggregation and trunking between 10 ports of 10/100/1000 Ethernet and 1 port of 10G Ethernet
- Enterprise and Metro Ethernet switches
- Aggregation for WDM and DWDM transport
- 10G Ethernet Uplink for Switches

### SPECIFICATIONS

- Reference frequency of 156.25 MHz  $\pm 100$  ppm driven to on-chip synthesizers as either single-ended LVTTTL or differential LVPECL
- Data transmission clocks options of 312.5 MHz or 390.625 MHz
- Data receive clock speeds from 311 MHz to 450 MHz
- Power supplies of 1.8V, 2.5V and 3.3V required

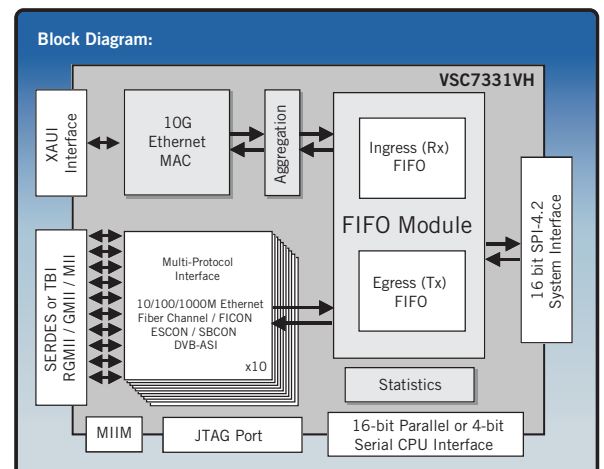

## Features

- Ten individually configurable ports of 10/100/1000 Ethernet, Fibre Channel/FICON, ESCON/SBCON, or DVB-ASI
- Each port provides a 10/100/1000 Ethernet MAC supporting RGMII/GMII/MII/TBI or a Gigabit Ethernet SerDes Interface for direct connection to optical modules
- TBI for direct connection to multi-protocol PHY/SerDes products
- Transparent GFP mapping of 8B/10B protocols with client signal monitoring and statistics
- One 10 Gigabit Ethernet MAC with integrated XAUI SerDes interface compliant with IEEE 802.3ae
- Standard 10G SPI-4.2 datapath interface supports 10 channels
- Loss-less flow control in Metro applications up to 10km
- 3 Mbit ingress and 1 Mbit egress FIFOs for short-haul flow control and to smooth bursty conditions
- Broad link aggregation and trunking solutions between interfaces
- Advanced shaping and policing per port
- Intelligent VLAN and MPLS tagging and un-tagging feature
- Full RMON 1 statistics group and applicable IEEE-802.3 and SNMP statistics

### Network Application Diagram:

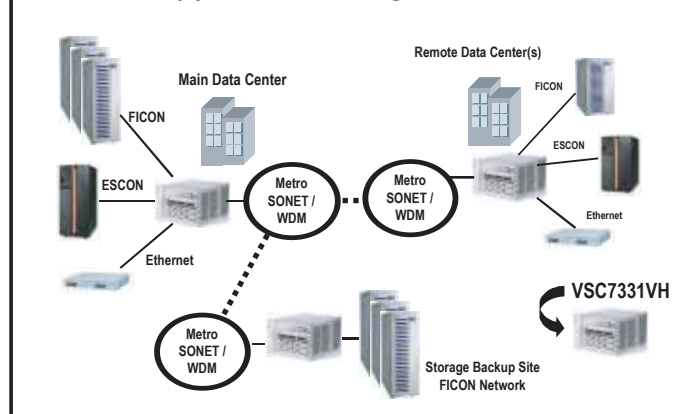

## Benefits

- Ten multi-protocol, multi-rate ports can be individually configured for any protocol, eliminating protocol-specific line card inventory and maximizing connected port density and rack utilization
- Intelligent VLAN and MPLS tagging/un-tagging improve client aggregation and bandwidth utilization
- Link aggregation and trunking between the 10GbE interface and either the SPI-4 or 10-port multi-protocol interfaces simplify management of flows across multiple clients
- Transparent GFP support enables the transport of mixed LAN and SAN data between enterprise sites, increasing the flexibility of business networking options

## Related Vitesse Products

Visit [www.vitesse.com](http://www.vitesse.com) for information about other related Vitesse products.

### Line Card Application Diagram:

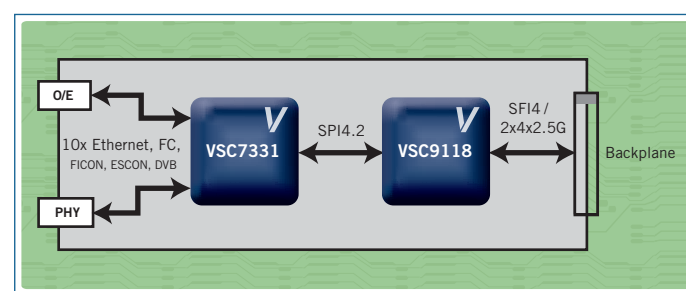

741 Calle Plano • Camarillo, CA 93012 USA • Tel: +1.800.VITESSE • +1.805.388.3700 • Fax: +1.805.987.5896 • [www.vitesse.com](http://www.vitesse.com)

Vitesse Semiconductor Corporation