Features

- Fully Compliant to VAN Specification ISO/11519.3
- Handles All Specified Module Types
- Handles All Specified Message Types
- Handles Retransmission of Frames on Contention and Errors
- 3 Separate Line Inputs with Automatic Diagnosis and Selection
- 1 Mbit/s Maximum Transfer Rate
- Normal or Pulsed (Optical and Radio Mode) Coding
- Intel[®], NEC[®], Texas Instruments[®] and Motorola[®] Compatible 8-bit Microprocessor Interface
- Multiplexed Address and Data Bus
- Idle and Sleep Modes
- 128 Bytes of General-purpose RAM
- DMA Capabilities for Message Handling
- 14 Identifier Registers with All Bits Individually Maskable
- 6-source Maskable Interrupt Including an Interrupt-on-reset to Detect Glitches on the Reset Pin
- Integrated Crystal or Resonator Oscillator with Internal Baud Rate Generator and Buffered Clock Output
- Single +5V Power Supply
- 0.5 mm CMOS Technology
- SOP 24 Packaging

Description

Cost optimization in car manufacturing is of extreme importance today. Solutions to this problem often implies the use of more advanced and intelligent electronic circuits. The TSS461F is a circuit which allows the transfer of all the status information needed in a car or truck over a single low-cost wire pair, thereby, minimizing the electrical wire usage.

It can be used to interconnect powerful functions (ABS, dashboard, power train control) and to control and interface car body electronics (lights, wipers, power window, etc.).

The TSS461F is fully compliant with the ISO standard 11519-3. This standard supports a wide range of applications such as low-cost remote control switches, typically used for lamp control; complex, highly-autonomous, distributed systems like engine controls, which require fast and secure data transfers.

The TSS461F is a microprocessor-interfaced line controller for mid-to-high complexity bus-masters and listeners like injection/ignition control calculators, dashboard controllers and car stereo or mobile telephone CPUs.

The microprocessor interface consists of a 256-bytes of RAM and the register area is divided into 11 control registers, 14 channel register sets and 128 bytes of general purpose RAM, used as a message storage area, and a 6-source maskable interrupt.

The circuit operates in RAM using DMA techniques, controlled by the channel and control registers. This allows virtually any microprocessor to interface with ease to the TSS461F, and to use the free RAM as a scratch pad.

Messages are encoded in enhanced Manchester code, and an optional pulsed code for use with an optical or radio link, at a maximum bit rate of 1 Mbit/s. The TSS461F analyzes the messages received or transmitted according to 6 different criteria including some higher level checks.

In addition, the bus interface has three separate inputs with automatic source diagnosis and selection, allowing for multibus listening or the automatic selection of the most reliable source at any time if several line receivers are connected to the same bus.



VAN Data Link Controller

TSS461F



7615A-AUTO-02/06

Figure 1. Block Diagram

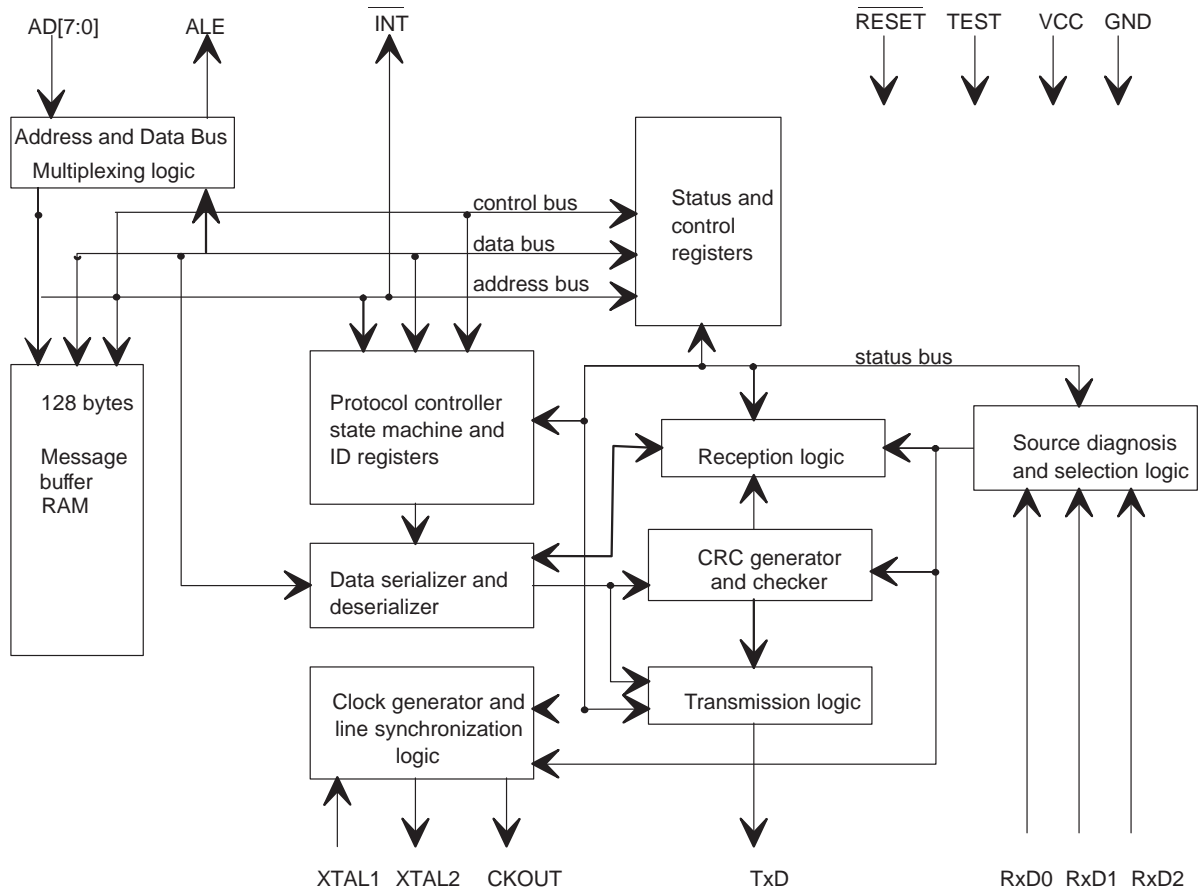

Pin Configuration

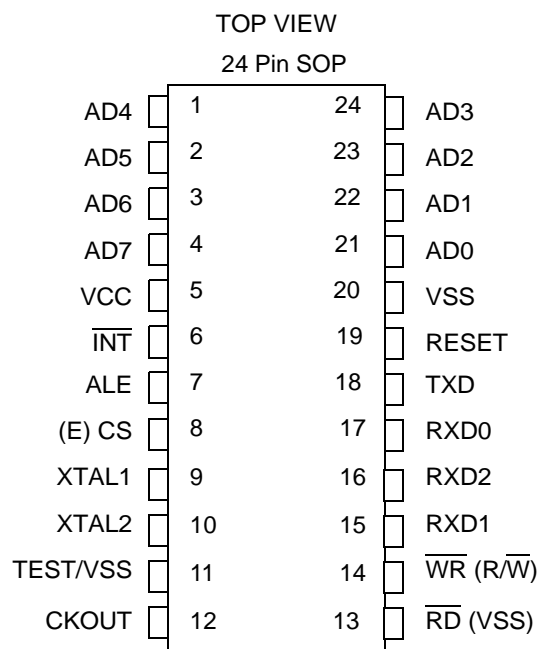

The names in parenthesis refer to the functionalities in Motorola mode.

I/O Type	Pin Name	Pin Number	Pin Function
I/O TTL	AD0	21	Multiplexed address and data bus. The address is latched on the falling address of ALE.
	AD1	22	
	AD2	23	
	AD3	24	
	AD4	1	
	AD5	2	
	AD6	3	
	AD7	4	
I Trigger TTL	ALE	7	Address Latch Enable
	$\overline{\text{RD}}$ (VSS)	13	Read Command
	$\overline{\text{WR}}$ (R/W)	14	Write Command
	CS(E)	8	Chip Select (active high)
Open-drain	INT	6	Interrupt
I Trigger CMOS Pull-down	RESET	19	Asynchronous general reset glitch filtered (12 ns)



I/O Type	Pin Name	Pin Number	Pin Function
I CMOS Pull-down	RXD0	17	VAN bus Inputs
	RXD1	15	
	RXD2	16	
3-state	TXD	18	VAN bus Output
I	XTAL1	9	Crystal oscillator or clock input pins
0	XTAL2	10	
0	CKOUT	12	Buffered clockout output enabled if no reset
Ground	TEST/VSS	11	Oscillator Ground
Power	VCC	5	+5V Power Supply
Ground	VSS	20	

Operation

The TSS461F is a microprocessor-controlled line controller for the VAN bus. It can interface to virtually any microprocessor, but the I/O signals of the circuit have been optimized for use with the TSC51/TSC251 series of microcontrollers.

It features a multiplexed address and data bus, controlled by an address strobe pin ALE and separated read \overline{RD} and write \overline{WR} command pins. The address is latched on the falling edge of ALE.

The circuit also features one single interrupt pin. This pin can be treated as level or edge sensitive. For example, if there is a pending interrupt inside the circuit when another interrupt is reset, the \overline{INT} pin will emit a high pulse with the same pulse width as the internal write strobe (typically 20 ns).

Figure 2. Typical Application

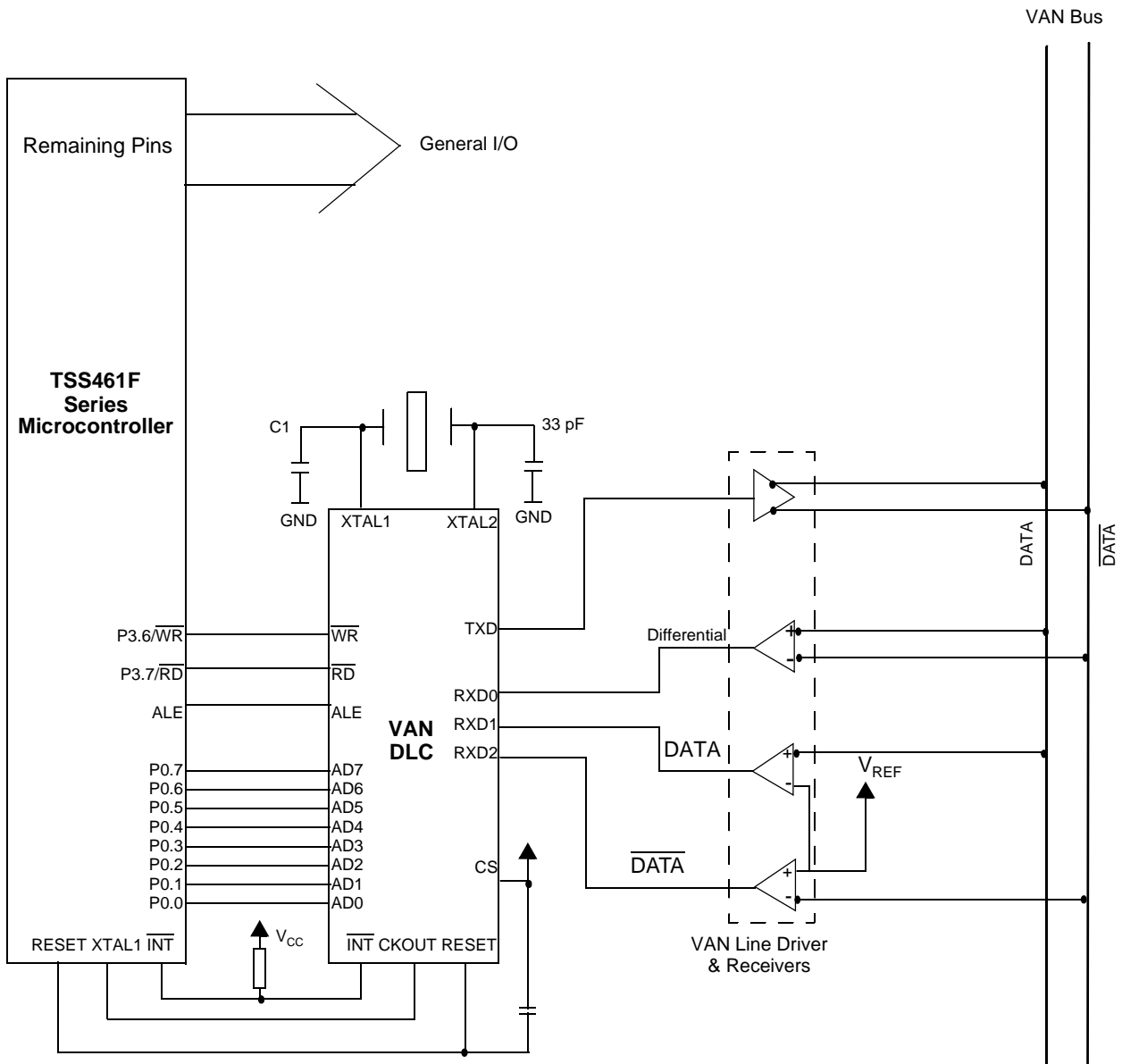



Microprocessor Interface

The processor controls the TSS461F by reading and writing the internal registers of the circuit. These registers appear to the processor as regular memory locations.

Interface Modes

The TSS461F must be plugged in an Intel or Motorola environment with an 8-bit address/data bus multiplexed.

Table 1. Access Mode Logic

CS (E)	\overline{RD}	\overline{WR} (R/ \overline{W})	Operation Mode
0			No operation
1	0	0	Write Operation in Motorola mode
1	0	1	Read operation in both modes
1	1	0	Write operation in Intel mode
1	1	1	No operation

In Intel environment, access operations need CS active, a read one with RD active, a write one with WR active. If TSS461F is the single peripheral in the processor space, CS can be wired to VCC.

In Motorola environment, the \overline{RD} pin is wired to VSS and the access operations are driven by CS (E). Contrary to Intel mode, CS (E) must never be wired to Vcc even if the TSS461F is alone.

To switch on-the-fly from one mode to the other, CS must be inactive.

Intel Mode

The Intel mode interface consists of 13 pins. 8 pins are the multiplexed address and data bus, and the rest are the address strobe, the read and write commands, the chip select and the interrupt request pins.

To access the memory locations in Intel mode, the processor must first assert a valid address on the multiplexed address and data bus and drive the address strobe pin high. When the required set up time has passed, the processor must drive the address strobe low, and keep the address valid for the required hold time.

The processor must then either assert the data to be written on the address and data bus, if a write is intended, or float the data bus for a read. The next step is to drive either the write or read command pins low, according to the function required, and at the same time drive the chip select pin high.

The TSS461F access cycle is then terminated by driving the chip select and command pins low.

Note: that the chip select pin may be driven high for the entire access cycle, and may also remain high during and after the termination of the cycle.

Figure 3. Intel Read and Write Cycles

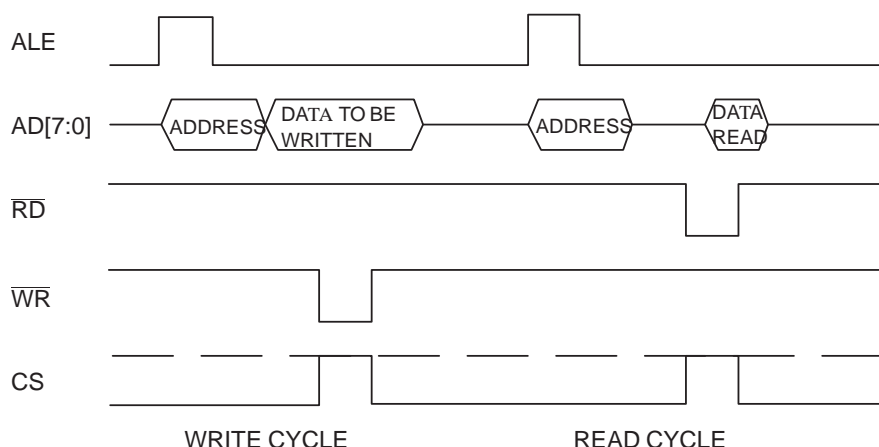

Motorola Mode

In Motorola mode, the \overline{WR} pin becomes the R/\overline{W} command, the \overline{RD} pin must be connected to ground and the CS pin becomes the E strobe. There is no separate chip select input. For example, if some external decoder is used, this decoder should not drive the E input high unless the processor's E output is high as well.

See Figure 4 for the Motorola read and write cycles. The main difference between Intel and Motorola mode is that the timing in Intel mode is referenced to the command signals (\overline{RD} and \overline{WR}), but in Motorola mode the reference is the E signal.

Figure 4. Motorola Read and Write Cycles

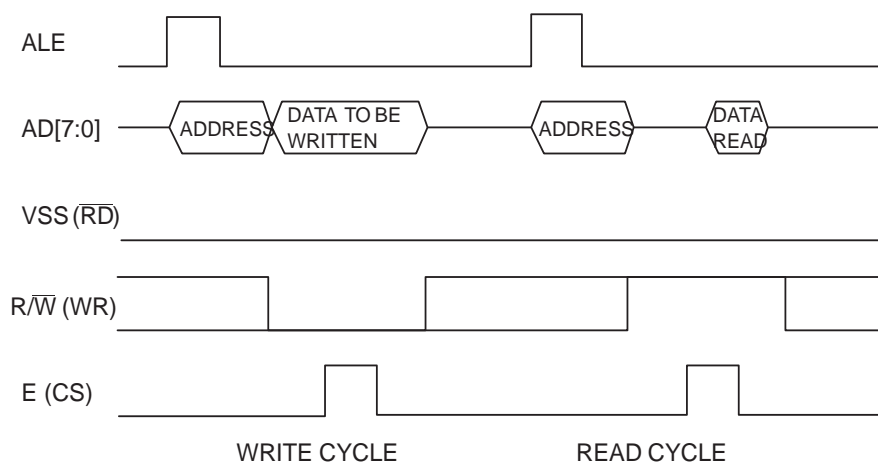

Interrupts

If an event occurs in the TSS461F, that needs the attention of the processor, this will be signalled on the active low, open-drain interrupt request pin. The events that create this request is controlled by the internal registers.

Every time the microprocessor accesses any of the interrupt registers (addresses 0x08 to 0x0B), the \overline{INT} pin will be released momentarily. This enables the TSS461F to work with processors that have either edge or level sensitive interrupt inputs.



Reset

The reset is applied asynchronously regarding XTAL clock. It can be done either by the RESET pin or by software. The RESET pin is a CMOS trigger input with a pull-down resistor (110 k Ω). An external 1 μ F capacitor to V_{CC} provides to RESET pin an efficient behavior.

The software reset is made through the GRES command bit of the Command Register (0x03).

The two resets are ored, filtered and gauged. T

he internal reset, always asserted asynchronously, enables the internal oscillator. Then it waits for eight clock periods the oscillator stability.

The different blocks of the TSS461F need to be turned on synchronously. So the release of the internal reset is synchronous and a loose of clock can let the TSS461F in permanent reset after applying Reset.

Oscillator

An oscillator is integrated in the TSS461F, and consists of an inverting amplifier which the input is XTAL1 and the output XTAL2.

A parallel resonance quartz crystal or ceramic resonator must be connected to these pins. As shown in Figure 2, two capacitors have to be connected from the crystal pins to ground. The values of C1 depend on the frequency chosen and can be selected using the graphic given in Figure 34.

If the oscillator is not used, then a clock signal must be fed to the circuit via the XTAL1 input.

Note, that this pin will behave as a CMOS level compatible Schmitt trigger input.

In this case, the XTAL2 output should be left unconnected. The oscillator also features a buffered clock output pin CKOUT. The signal on this pin is directly buffered from the XTAL1 input, without inversion.

There is one more pin used for the oscillator. The TEST/VSS pin is in fact its ground, and unless this pin is firmly connected to ground, with decoupling capacitors, the oscillator will not operate correctly.

The test mode itself, i.e., when the TEST/VSS pin is held high, is only intended for factory use, and the functionality of this mode is not specified in any way.

Furthermore, it is subject to change without notice, the only exception being for incoming inspection tests using the test program.

The clock signal is then fed to the clock generator generate all the necessary timing signals for the operation of the circuit. The clock generator is controlled by a 4-bit code called the clock divider.

$$F_{TSCLK} = \frac{F_{XTAL1}}{n \times 16}$$





Table 2. Clock Divider

Clock Divider	Divide by	8 MHz		6 MHz		4 MHz		2 MHz	
		KTS/s	Kbits/s	KTS/s	Kbits/s	KTS/s	Kbits/s	KTS/s	Kbits/s
0000	1	500	400	375	300	250	200	125	100
0001	2	250	200	187.50	150	125	100	62.50	50
0010	4	125	100	93.75	75	62.50	50	31.25	25
0011	8	62.5	50	46.875+	37.5	31.25	25	15.625	12.5
0100	16	31.25	25	23.438	18.75	15.625	12.5	7.813	6.25
0101	32	15.625	12.5	11.718	9.375	7.813	6.25	3.906	3.125
0110	64	7.813	6.25	5.859	4.688	3.906	3.125	1.953	1.562
0111	128	3.906	3.125	500	400	1.953	1.562	166.666	133.333
1000	1.5	333.333	266.666	250	200	166.666	133.333	83.333	66.666
1001	3	166.666	133.333	125	100	83.333	66.666	41.666	33.333
1010	6	83.333	66.666	62.50	50	41.666	33.333	20.833	16.666
1011	12	41.666	33.333	31.25	25	20.833	16.666	10.416	8.333
1100	24	20.833	16.666	15.625	12.50	10.416	8.333	5.208	4.166
1101	48	10.416	8.333	7.813	6.25	5.208	4.166	2.604	2.083
1110	96	5.208	4.166	3.906	3.125	2.604	2.083	1.302	1.042
1111	192	2.604	2.083	1.953	1.5625	1.302	1.042	0.651	0.521

VAN Protocol

Line Interface

There are three line inputs and one line output available on the TSS461F. Each of the three inputs to use is either programmed by software or automatically selected by a diagnosis system.

The diagnosis system continuously monitors the data received through the three inputs, and compares them and the selected bitrate. It then chooses the most reliable input according to the results.

The data on the line is encoded according to the VAN standard ISO/11519-3. This means that the TSS461F is using a two-level signal having a recessive (1) and a dominant (0) state. Furthermore, due to the simple medium used, all data transmitted on the bus is also received simultaneously.

Consequently, the VAN protocol is a CSMA/CD (Carrier Sense Multiple Access/Collision Detection) protocol, allowing for continuous bitwise arbitration of the bus, and non-destructive (for the higher priority message) collision detection.

Figure 5. CSMA/CD Arbitration

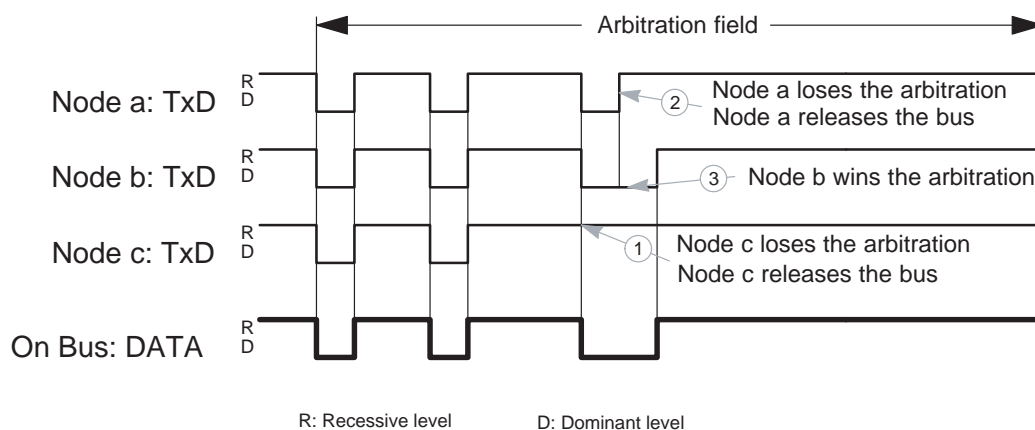

In addition to the VAN specification there is also a pulsed coding of the dominant and recessive states. This mode is intended to be used with an optical or radio link. In this mode, the dominant state for the transmitter is a low pulse, (2x prescaled clocks at the beginning of the bit) and the recessive state is just a high level.

When receiving in this mode, it is not the state of the signal which is decoded, but the edges. Also, reception is imposed on the RxD0 input, and the diagnosis system does not operate correctly.

In addition, in this mode there is an internal loopback in the circuit since optical transceivers are not able to receive the signal that they transmit.

Figure 6. State Encoding

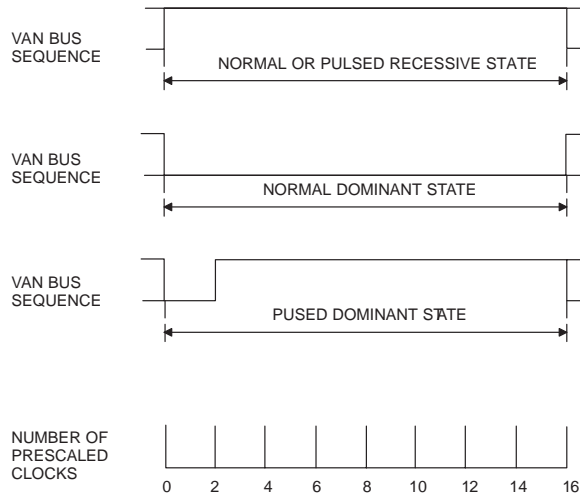

In Figure 6 the pulsed waveforms are shown. In Figure 9 through Figure 15 the low "timeslots" (i.e. blocks of 16 prescaled clocks) should be replaced by the dominant waveform showed in Figure 6, if the correct representations for pulsed coding is desired.

VAN Frame

Figure 7. VAN Bus Frame

SOF	Identifier Field	Command				Data Field	Frame Check Sum	EOD	ACK	EOF
		EXT	RAK	R/W	RTR					

The VAN bus supports three different module (unit) types:

1. The Autonomous module, which is a bus master. It can transmit Start Of Frame (SOF) sequences, it can initiate data transfers and can receive messages.
2. The Synchronous access module. It cannot transmit SOF sequences, but it can initiate data transfers and can receive messages.
3. The Slave module, which can only transmit using an in-frame mechanism and can receive messages.

Figure 8. Hierarchical Access Methods

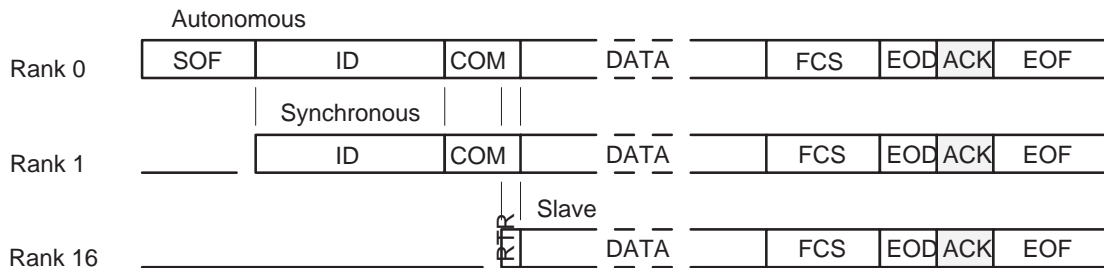
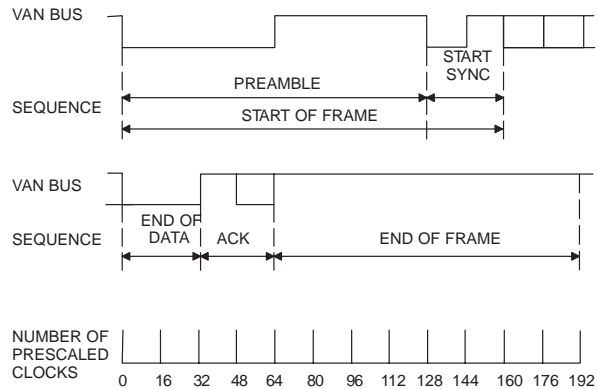

Figure 7 shows a normal VAN bus frame. It is initiated with a Start of Frame (SOF) sequence shown in Figure 9. The SOF can only be transmitted by an autonomous module. During the preamble, the TSS461F will synchronize its bit rate clock to the data received.

Figure 9. Framing Sequences



When the complete SOF sequence has been transmitted or received, the circuit will start the transmission or reception of the identifier field.

All data on the VAN bus, including the identifier and Frame Check Sum (FCS), are transmitted using enhanced Manchester code.

In enhanced Manchester code, three NRZ bits are transmitted first followed by one Manchester bit, then three more NRZ bits followed by one Manchester bit and so on.

Since the high state is recessive and the low state is dominant, the bus arbitration can be done. If a module wants access to the bus, it must first listen to the bus during one full End of Frame (EOF) and one full Inter Frame Spacing (IFS) period, to determine whether the bus is free or not (i.e., no dominant states received).

Figure 10. Data Encoding

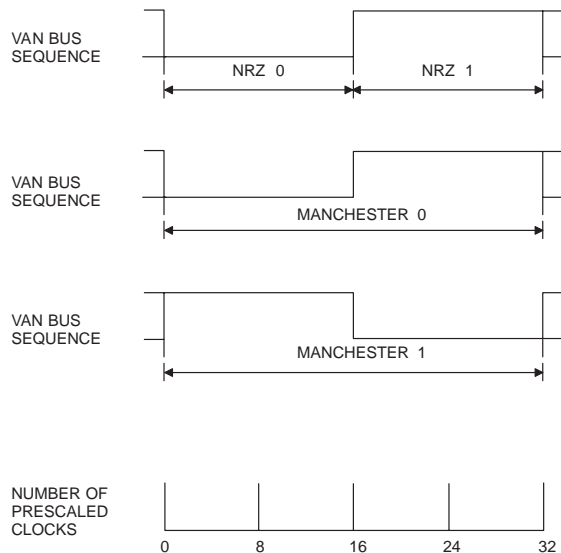

The IFS is defined to be a minimum of 64 prescaled clocks periods. The TSS461F, accepts an IFS of zero prescaled clocks for the reception only of a SOF sequence.



Once the bus is free, the module must now, if it is an autonomous module emits a SOF sequence or, if it is a synchronous access module, wait until it detects a preamble sequence.

Up till this point there can be several modules transmitting on the bus, and there is no possibility of knowing if this is the case or not. Therefore, the first field in which arbitration can be performed is the identifier field. Since the logical zeroes on the bus are dominant, and all data is transmitted with the most significant bit (MSB) first, the first module to transmit a logical zero on the bus will be the prioritized module, i.e., the message that is tagged with the lowest identifier will have priority over the other messages.

However it is possible that two messages transmitted on the bus will have the same identifier. The TSS461F therefore, continues the arbitration of the bus throughout the whole frame. In addition, if the identifier in transmission has been programmed for reception as well, it transmits and receives messages simultaneously, right up till the Frame Check Sequence (FCS). Only then, if the TSS461F has transmitted the whole message. It discards the message received. Arbitration loss in the FCS field is considered as a CRC error during transmission.

This feature is called full data field arbitration, and it enables the user to extend the identifier. For instance, it can be used to transmit the emitting modules address in the first bytes of the data field, thus enabling the identifier to specify the contents of the frame and the data field to specify the source of the information.

The identifier field of the VAN bus frame is always 12 bits long, and it is always followed by the 4-bit command field:

- The first bit of the command is the extension bit (EXT). This bit is defined by the user on transmission and is received and retained by the TSS461F. To conform with the standard, it should be set to 1 (recessive) by the user, else the frame is ignored without any IT generation.
- The second bit is the request ACKnowledge bit (RAK). If this bit is a logical one, the receiving module must acknowledge the transfer with an in-frame acknowledgement in the ACK field. If it is set to logical zero, then the ACK field must contain an acknowledge absent sequence.
- The third bit is the Read/Write bit (R/W). This bit indicates the direction of the data in a frame.
- If set to zero it is a "write" message, i.e. data transmitted by one module to be received by another module. If it is set to one it implies a "read" message, i.e., a request that another module should transmit data to be received by the one that requested the data (reply request message).
- Last in the command field is the Remote Transmission Request bit (RTR). This bit is a logical zero if the frame contains data and a logical one if the frame does not contain data. In order to conform with the standard a received frame included the combination R/W. RTR = 01 is ignored without any IT generation.

All the bits in the command field are automatically handled by the TSS461F, so the user doesn't need to be concerned for the encoding and decoding of these. The command bits transmitted on the VAN bus are calculated from the current status of the active message.

After the command field comes the data field. This is just a sequence of bytes transmitted, MSB first. In the VAN standard the maximum message length is set to 28 bytes, but the TSS461F handles messages up to 30 bytes.

The next field is the FCS field. This field is a 15 bit CRC checksum defined by the following generator polynomial $g(x)$ of order 15:

$$g(x) = x^{15} + x^{11} + x^{10} + x^9 + x^8 + x^7 + x^4 + x^3 + x^2 + 1$$

The division is done with a rest initialized to 0x7FFF, and an inversion of the CRC bits is performed before transmission.

However, since the CRC is calculated automatically from the identifier, command and data fields by the TSS461F, the user should not be concerned with the circuit. When the frame check sequence has been transmitted, the transmitting module must transmit an End Of Data (EOD) sequence, followed by the ACKnowledge field (ACK) and the End of Frame sequence (EOF) to terminate the transfer.

Figure 11. Acknowledge Sequences

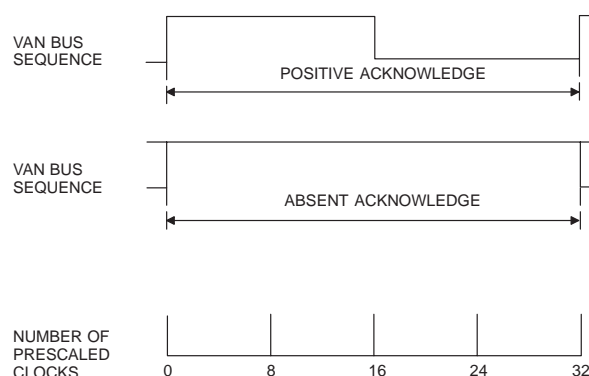

Frame Examples

The frames transmitted on the VAN bus are generated by several modules, each supplying different parts of the message. Figure 12 through Figure 15 show the four frame types specified in the VAN standard, and what module is generating the different fields.

- The most straightforward frame is the normal data frame in Figure 13. Like all other frames it is initiated with a SOF sequence. This sequence is generated by a bus master (not shown in figure).
- During this frame, there is basically only one module transmitting with the exception being the acknowledgement, generated by the receiving module if requested in the RAK bit.
- The reply request frame with immediate reply in Figure 13 is the only frame in which a slave module can transmit data by filling it into the appropriate field.
- The difference for the frame on the bus is that the R/W bit has changed state compared to the normal frame.
- This is a highly interactive frame where a bus master generates the SOF and the initiator generates the identifier, the three first bits of the command, and the acknowledge. The RTR bit, the data field, the frame check, the EOD and the EOF are all generated by the replying module.
- The reply request frame with deferred reply in Figure 14 is the same frame as the reply request frame with immediate reply. But since the requested module does not generate the RTR bit, the requesting module will continue with the frame check, the EOD and the EOF.
- During this frame, the requested module will only generate the acknowledge, and only if this was requested by the initiator through the RAK bit.
- Finally, the deferred reply frame in Figure 16 which is sent when a module has prepared a reply for a reply request that has been received earlier. This frame is similar to the normal data frame with the exception being the R/W bit that has changed state.

Figure 12. Normal Data Frame

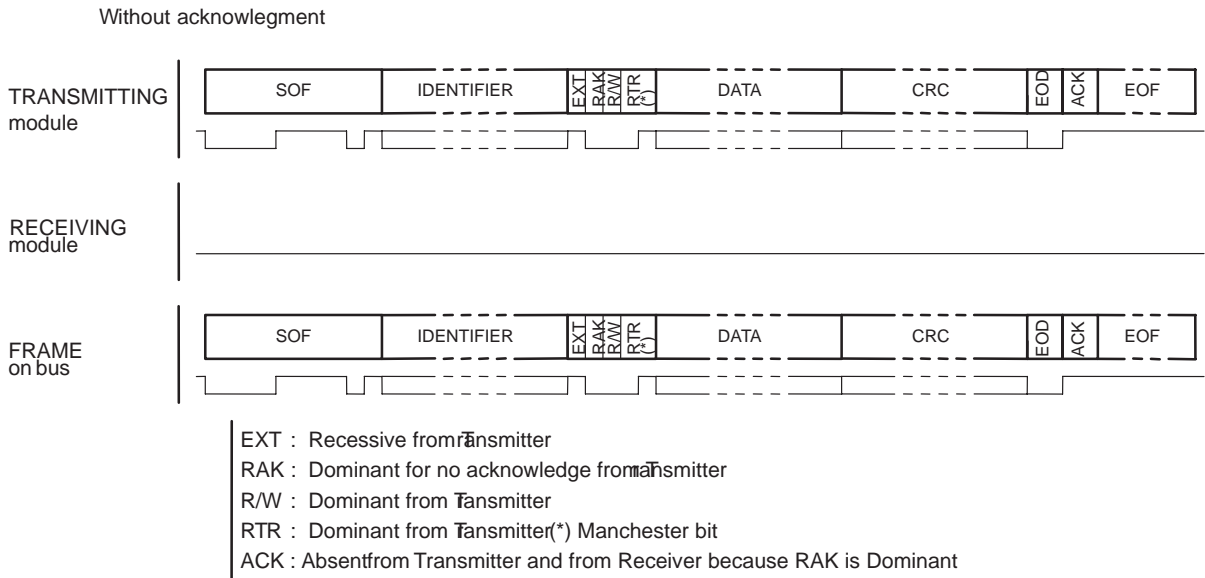
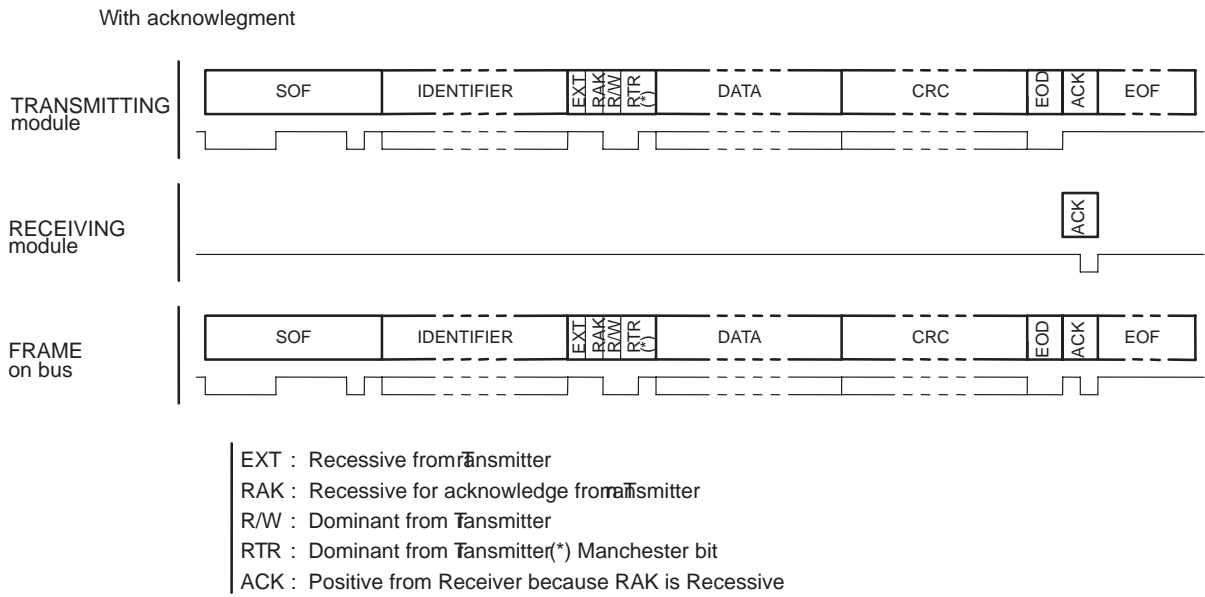

Figure 13. Reply Request Frame with Immediate Reply

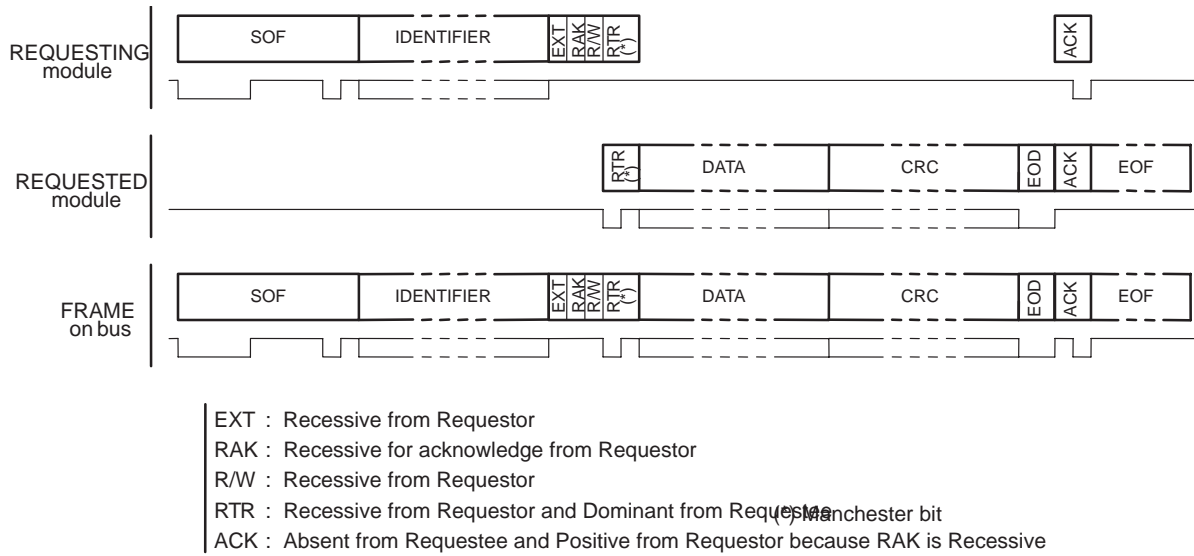

Figure 14. Reply Request Frame with Deferred Reply

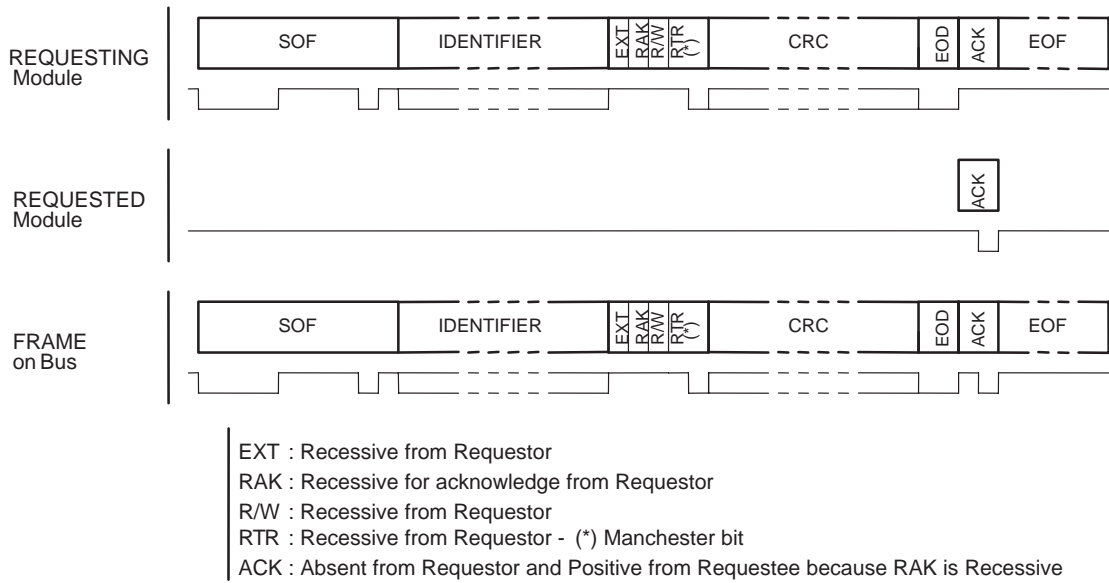
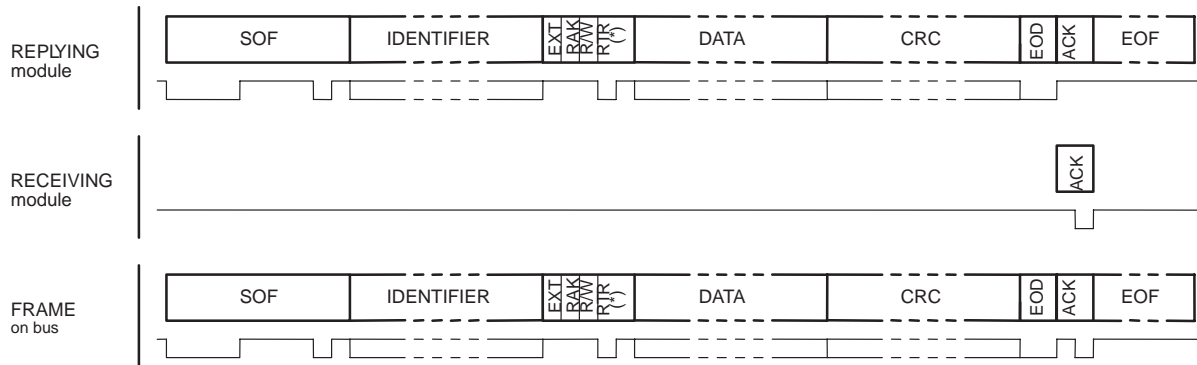

Figure 15. Deferred Reply Frame



- EXT : Recessive from Replyer
- RAK : Recessive for acknowledge from Replyer
- R/W : Recessive from Replyer
- RTR : Dominant from Replyer (*) Manchester bit
- ACK : Absent from Replyer and Positive from Receiver because RAK is Recessive

Diagnosis System

The purpose of the diagnosis system is to detect any short or open circuits on either the DATA or $\overline{\text{DATA}}$ lines and to permit, if it is possible, to carry the communications on the non-defective line.

The diagnosis system is based on the assumption that three separate line receivers are connected to the VAN bus (see Figure 3):

- One of the line receivers is connected in differential mode, sensing both DATA and $\overline{\text{DATA}}$ signals, and is connected to the RxD0 input.
- The other two line receivers are operating in single wire mode and are sensing only one of the two VAN bus signals:
 - The line receiver sensing DATA is connected to RxD1
 - The line receiver sensing $\overline{\text{DATA}}$ is connected to RxD2

The diagnosis system analyzes and compares the data sent over both VAN lines. So, the diagnosis system executes a digital filtering and transition analyses. In order to perform its investigation, three internal signals are generated, RI (Return to Idle), SDC (Synchronous Diagnosis Clock) and TIP (Transmission In Progress).

One of four operating modes can be chosen to manage the results of the diagnosis system.

Diagnosis States

If the diagnosis system finds a failure on either of the VAN bus signals, it changes from nominal to degraded mode, and connects the line receiver not coupled to the failing signal to the reception logic.

When the diagnosis system finds that the failing signal is working again, it returns to nominal mode and re-connects the differential line receiver to the reception logic.

A major error occurs when both the VAN bus signals fail.

Figure 16. Diagnosis States

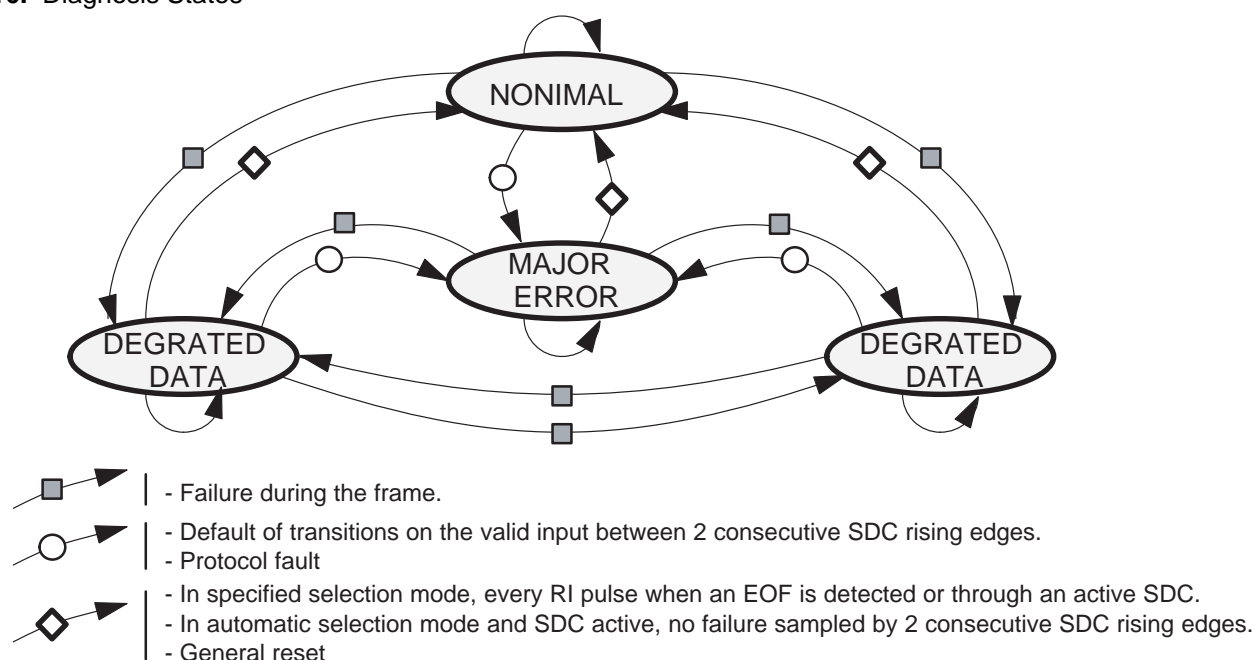

Status bits give permanent information on the diagnosis performed, whatever the programmed operating mode. This is encoded over three bits: Sa, Sb and Sc. Sa and Sb bits indicate the four possible states of the VAN bus.

Table 3. Status Bits Sa and Sb

Sa	Sb		Communication
0	0	Mode	nominal
		Fault	no fault on VAN bus
		Status	differential communication DATA and $\overline{\text{DATA}}$
0	1	Mode	degraded on DATA
		Fault	fault on $\overline{\text{DATA}}$
		Status	communication on $\overline{\text{DATA}}$
1	0	Mode	degraded on DATA
		Fault	fault on $\overline{\text{DATA}}$
		Status	communication on $\overline{\text{DATA}}$
1	1	Mode	major error
		Fault	fault on DATA and $\overline{\text{DATA}}$
		Status	no communication on DATA and $\overline{\text{DATA}}$ (attempt to communicate alternatively on DATA then $\overline{\text{DATA}}$ every SDC period.

- Notes:
1. Sc bit sets to 1 as soon as one of the three inputs (RXD2, RXD1, RXD0) differs from the others in the input comparison analysis performed by the diagnosis system, S2 is set.
 2. The only way to reset this status bit is through the RI signal or a general reset.

Internal Operations

Digital Filtering

If several spurious pulses occur during one bit, the diagnosis for defective conductor may be corrupted. To avoid such errors, digital filters are implemented.

Filtering operation is based on sampling of the comparator output signals. A transition is taken into account only if it is observed over five samples (1/16th of timeslot).

Transition Analyses

These analyses are continuously done on the effective edges on comparators after digital filtering.

- Asynchronous diagnosis:
The asynchronous diagnosis is done by comparing the number of edges on DATA and $\overline{\text{DATA}}$.
If four edges are detected on one input and no edges on the other during the same period, the second input is considered faulty and the diagnosis mode will change to one of the degraded modes.
- Synchronous diagnosis:
The synchronous diagnosis counts the number of edges on the data input connected to the reception logic during one SDC period.
If there are less than four edges during one SDC period, the diagnosis mode will change to the major error mode.
- Transmission diagnosis:
The transmission compares RxD1 and RxD2 inputs (through the input comparators and the

filters) with the data transmitted on TxD output.

At a time when the transmission logic generates a dominant (recessive transition), the inputs can give different values. Taking into account the filtering delay, the bus line seen as dominant is assumed to be correct, the other one, recessive, is considered faulty. The diagnosis mode is changed to reflect that.

- **Protocol fault:**
The protocol fault is detected by counting the number of consecutive dominant timeslots. If eight consecutive timeslots are dominant, the diagnosis mode will change to the major error mode.

Generation of Internal Signals

RI Signal (Return to Idle)

This signal is used to return to nominal mode in the three specified selection modes (see section “Diagnosis States” and section “Programming Modes”). The RI signal is disabled in automatic selection mode.

The RI signal is a pulse generated when an EOF is detected. So, at the end of each frame, the user, regarding the diagnosis status bit Sa, Sb & Sc, can select its own choice.

SDC Signal (Synchronous Diagnosis Clock)

This time base is used by diagnosis system in automatic selection mode (see section “Programming Modes”) when no event is recorded on the bus.

The SDC is generated either by a special SDC divider connected to the timeslot clock, or manually. The SDC clock period must be longer compared to the timeslot duration.

A typical SDC period should be greater than the maximum frame length appearing on the VAN network.

TIP Signal (Transmission In Progress)

This signal must be enabled to allow the transmission diagnosis (see section “Transition Analyses”).

The TIP turns on synchronously at the beginning of the transmission:

- For asynchronous bus access, the beginning of SOF,
- For synchronous bus access, the beginning of the identifier field,
- For a request of in frame reply, the RTR bit of the command field.

The TIP turns off synchronously at the end of the transmission:

- after EOF
- after a losing of arbitration or a code violation detection
- for a requester of in frame reply, when the arbitration is lost on RTR the bit.

This signal is not generated when the transmission logic only sends an ACK.



Programming Modes

Four programming modes determine the way for using three different inputs and the diagnosis system.

- 3 specified selection modes
- 1 automatic selection mode

Table 4. Programming Modes

Ma	Mb	Operating Mode
0	0	Differential communication
0	1	Degraded communication on RxD2 ($\overline{\text{DATA}}$)
1	0	Degraded communication on RxD1 (DATA)
1	1	Automatic selection according to the diagnosis status

Registers

The TSS461F memory map consists of three different areas, the Control & Status registers, the Channel Registers and the Message Data (or Mailbox).

Mapping

Figure 17. Memory Map

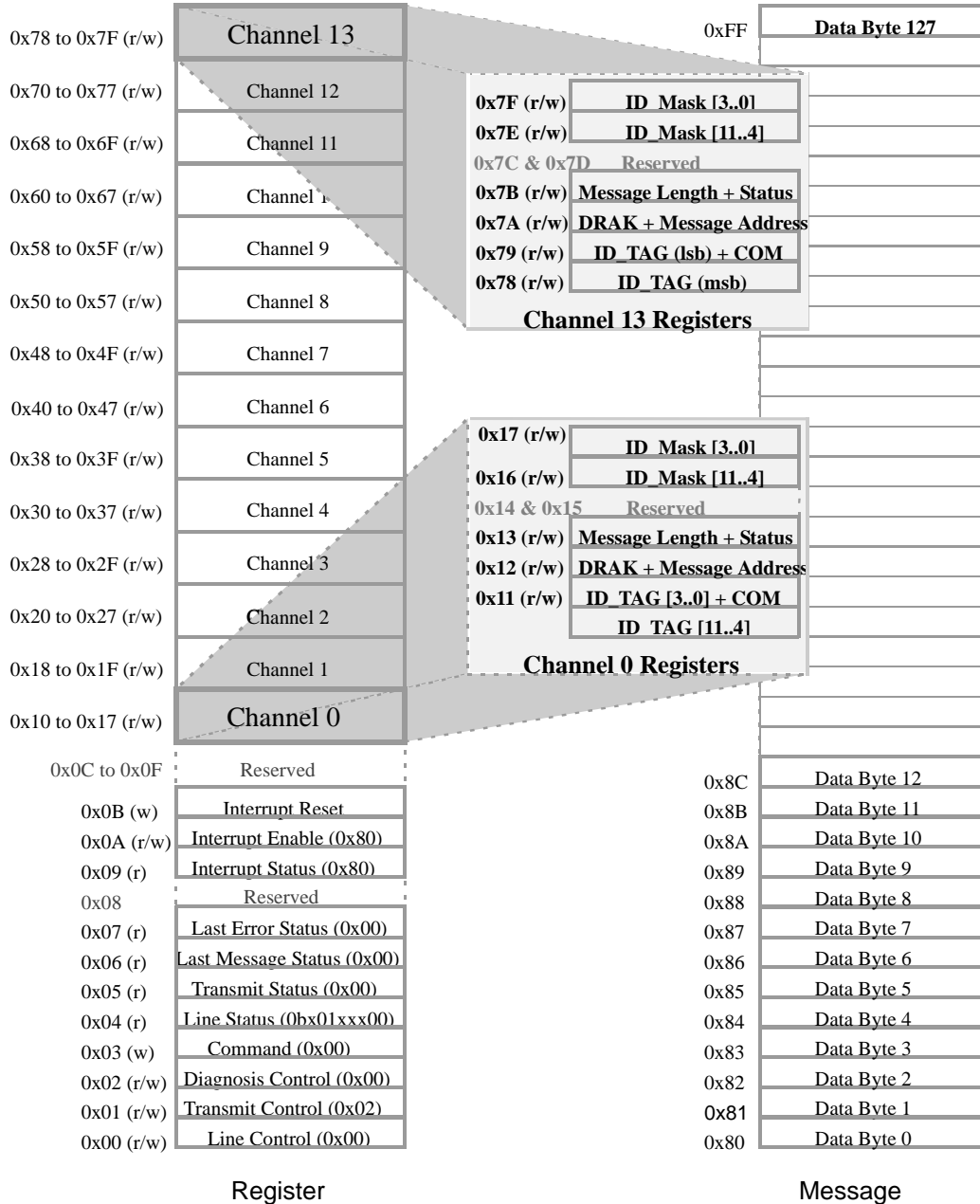

- Notes:
1. All the non-specified addresses between 0x00 and 0x7F are considered as absent.
 2. (r) means read only register.
(w) means write only register.
(r/w) means read/write register.
 3. Value after RESET is found after register name. If no value is given, the register is not initialized at RESET.



Control and Status Registers

Line Control Register (0x00)

7	6	5	4	3	2	1	0
MR3	MR2	MR1	MR0	VER2	VER1	VER0	MT

- Read/write register.
- Default value after reset: 0y00
- reserved: Bit 2, this bit cannot be set by the user; a 0 must always be written to this bit.

CD[3:0] Clock Divider

They control the VAN Bus rate through a Baud Rate generator according to the formula below:

$$F_{TCLK} = \frac{F_{XTAL1}}{n \times 16}$$

PC Pulsed CodeOne

The TSS461F will transmit and receive data using the pulsed coding mode (i.e optical or radio link mode). The use of this mode implies communication via the RXD0 input and the non-functionality of the diagnosis system.

Zero: (default at reset) The TSS461F will transmit and receive data using the Enhanced Manchester code (RXD0, RXD1, RXD2).

IVTX

Invert TXD output.

IVRX

Invert RXD inputs. The user can invert the logical levels used on either the TXD output or the RXD inputs in order to adapt to different line drivers and receivers.

One: A one on either of these bits will invert the respective signals.

Zero: (default at reset). The TSS461F will set TXD to recessive state in Idle mode and consider the bus free (recessive states on RXD inputs).

Transmit Control Register (0x01)

7	6	5	4	3	2	1	0
MR3	MR2	MR1	MR0	VER2	VER1	VER0	MT

- Read/Write register
- Default value after reset: 0x02

MR[3:0]: Maximum Retries

These bits allow the user to control the amount of retries the circuit will perform if any errors occurred during transmission.

Table 5. Retries

MR [3:0]	Max Number of Retries	Max Number of Transmits
0000	0	1
0001	1	2
0010	2	3
0011	3	4
0100	4	5
0101	5	6
0110	6	7
0111	7	8
1000	8	9
1001	9	10
1010	10	11
1011	11	12
1100	12	13
1101	13	14
1110	14	15
1111	15	16+

Note: Bus contention is not regarded as an error and that an infinite number of transmission attempts will be performed if bus contention occurs continuously.

VER[2:0]: DLC Version After Reset

- 000: TSS461A & B
- 001: TSS461C and TSS461F

These bits cannot be set by user; 001 must always be written to these bits.

MT: Module Type

The three different module types are supported (see section “VAN Frame”):

One: The TSS461F is an autonomous module (Rank 0), an synchronous access module (Rank 1) or a slave module (Rank 16).

Zero: The TSS461F is an synchronous access module (Rank 1) or a slave module (Rank 16).



Diagnosis Control Register (0x02)

7	6	5	4	3	2	1	0
SDC3	SDC2	SDC1	SDC0	Ma	Mb	ETIP	ESDC

- Read/Write register
- Default value after reset: 0x00.

The diagnosis is discussed in detail in section “Diagnosis States”.

- In its four high order bits the user can program the SDC rate SDC [3:0]
- In its two medium order bits the diagnosis system mode is controlled: M1, M0
- In the two low order bits, the user controls if the SDC and TIP are to be generated automatically ETIP, ESDC

SDC [3:0]: SDC divider The input clock is the times lot clock.

Table 6. System Diagnosis Clock Divider

SDC Divider SDC [3:0]	Divide By
0000	64
0001	128
0010	256
0011	512
0100	1024
0101	2048
0110	4096
0111	8192
1000	16384
1001	32768
1010	65536
1011	131072
1100	262144
1101	524288
1110	1048576
1111	2097152

Ma, Mb: Operating mode command bits

Table 7. Diagnosis System Command Bits

Ma	Mb	
0	0	Forces the Communication on RxD0 (differential)
0	1	Forces the Communication on RxD2 ($\overline{\text{DATA}}$)
1	0	Forces the Communication on RxD1 (DATA)
1	1	Automatic selection

ETIP: Enable Transmission In Progress

One: Enable TIP generation

Zero: Disable TIP generation.

- The Transmission In Progress (TIP) tells the diagnostic system to enable transmission diagnosis.

ESDC: Enable System Diagnosis Clock

One: Enable SDC divider.

Zero: Disable SDC divider.

-The Synchronous Diagnosis Clock (SDC) controls the cycle time of the synchronous diagnosis.

Command Register (0x03)

7	6	5	4	3	2	1	0
GRES	SLEEP	IDLE	ACTI	REAR	0	0	MSDC

- Write only register.
- Reserved: Bit 1, 2 these bit cannot be set by the user; a zero must always be written to these bit.
- If the circuit is operating at low bit rates there might be a considerable delay between the writing of this register and the performing of the actual command (worst case 6 timeslots). The user must verify, by reading the Line Status Register (0x04) that the commands have been performed.

GRES: General Reset

The Reset circuit command bit performs, if set, exactly as if the external reset pin was asserted. This command bit has its own auto-reset circuitry.

One: Reset active

Zero: Reset inactive

SLEEP: Sleep Command

If the user sets the Sleep bit, the circuit will enter sleep mode. When the circuit is in sleep mode, all non-user registers are setup to minimize power consumption and the oscillator is stopped. To exit from this mode, the user must set either the idle or activate commands.

One: Sleep active

Zero: Sleep inactive



IDLE: Idle Command

If the user sets the Idle bit, the circuit will enter idle mode. In idle mode the oscillator will operate, but the TSS461F will not transmit or receive anything on the bus, and the TXD output will be in three-state

- One: Idle active
- Zero: Idle inactive

ACTI: Activate Command

The Activate command will put the circuit in the active mode, i.e it will transmit and receive normally on the bus. When the circuit is in activate mode the TXD three-state output is enabled.

- One: Activate active
- Zero: Activate inactive

REAR: Re-Arbitrate Command

This command will, after the current attempt, reset the retry counter and re-arbitrate the messages to be transmitted in order to find the highest priority message to transmit.

- One: Re-arbitrate active
- Zero: Re-arbitrate inactive

MSDC: Manual System Diagnosis Clock

Rather than using the SDC divider described in section "Diagnosis Control Register (0x02)", the user can use the manual SDC command to generate a SDC pulse for the diagnosis system.

This MSDC pulse should be high at least two timeslot clock.

Line Status Register (0x04)

7	6	5	4	3	2	1	0
x	SPG	IDG	Sc	Sb	Sa	TXG	RXG

Read only register.

- Default value after reset: 0bx01xxx00.
- This register reports the operation mode of the TSS461F in the Sleep an Idle bits (Command Register located at address 0y03) as well as the diagnosis system status bits S2 to S0 discussed in section "Diagnosis System".

SPG: Sleeping

IDG: Idling

Default mode at reset

Sa, Sb and Sc

Diagnosis system status bits

- Sa and Sb

Table 8. Diagnosis System Status Bits

Sb	Sa	Communication Indication
0	0	Nominal mode, differential communication
0	1	Degraded over \overline{DATA} , fault on DATA
1	0	Degraded over DATA, fault on \overline{DATA}
1	1	Major error, fault on DATA and \overline{DATA}

- Sc: As soon as one of the three inputs (RXD2, RXD1, RXD0) differs from the others in the input comparison analysis perform by the diagnosis system, S2 is set. The only way to reset this status bit is through the RI signal or a general reset.

TXG: Transmitting

If this status bit is active, it indicates that the TSS461F has chosen an identifier to transmit, and it will continue to make transmission attempts for this message until it succeeds or the retry count is exceeded.

RXG: Receiving

The receiving indicates that there is activity on the bus.

Note: For safe modification of active channel registers both bits should be inactive (except "abort" command).

Transmission Status Register (0x05)

7	6	5	4	3	2	1	0
NRT3	NRT2	NRT1	NRT0	IDT3	IDT2	IDT1	IDT0

- Read only register.
- Default value after reset: 0x00.
- The transmission Status register contains the number of retries made up-to-date, according to Table 3, and the channel currently in transmission.

NRT [3:0]: Number of Retries Done in Transmission

IDT [3:0]: Channel Number Currently in Transmission

Last Message Status Register (0x06)

7	6	5	4	3	2	1	0
NRTR3	NRTR2	NRTR1	NRTR0	IDTR3	IDTR2	IDTR1	IDTR0

- Read only register.
- Default value after reset: 0x00.
- This register is the same as the transmission status register. It contains the last identifier number that was successfully transmitted, received or exceeded its retry count. If it was a successful transmission, the number of retries performed can be seen in this register as well.



NRTR [3:0]: Number of retries done successfully in transmission. In case of reception NRTR[3:0] is undefined.

IDTR [3:0]: Channel number that was successfully transmitted, received or exceeded its retry count.

Last Error Status Register (0x07)

7	6	5	4	3	2	1	0
x	BOC	BOV	x	FCSE	ACKE	CV	FV

- Read only register.
- Default value after reset: 0x00.
- The Last Error Status Register contains the error code for the last transmission or reception attempt. It is updated after each attempt, i.e. several error codes can be reported during one single transmission (with several retries).

BOC: Buffer Occupied

- When one channel configured in “Reply request” mode has its “received” bit set when it attempts to transmit its request.
- BOC with the link capability between two channels sharing the same received buffer is set when one channel has already set its “received” bit in its “Message length and status Channel register” and a receive is attempted on the other one.

BOV: Buffer Overflow

BOV indicates that the buffer length setup in the Channel Status Register was shorter than the number of bytes received plus 1, therefore, some data got lost.

One: BOV active
Zero: BOV inactive

FCSE: Framing Check Sequence Error

FCSE indicates a mismatch between the FCS received and the FCS calculated

One: FCSE active
Zero: FCSE inactive

ACKE: Acknowledge Error

ACKE indicates a physical violation or collision on ACK field of the frame when the TSS463 is produced.

One: ACKE active
Zero: ACKE inactive

Figure 18. ACKE Status Bit

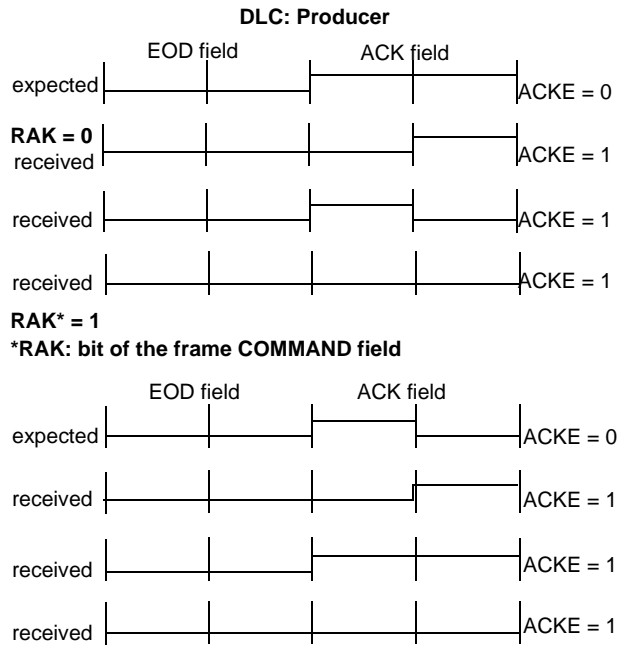

CV: Code Violation

CV indicates:

- either a Manchester code violation (2 identical TS on Manchester bit), or a physical violation (transmitted bit “dominant”, received bit “recessive”), on fields ID, COM, DATA and CRC, or
 - a physical violation or collision on field “preamble” and the “recessive” bit of the “Star Sync” field.
- One: CV active
Zero: CV inactive

FV: Frame Violation

FV indicates a physical violation or collision on ACK field of the frame when the TSS463 is consumed.

One: FV active
Zero: FV inactive

Figure 19. FV Status Bit

DLC: Consumer

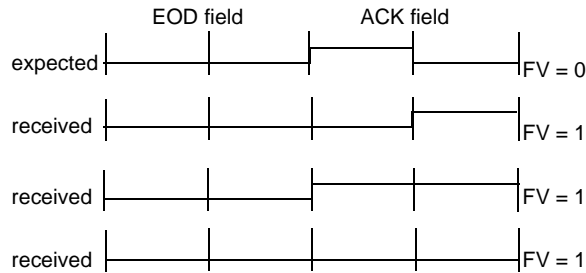
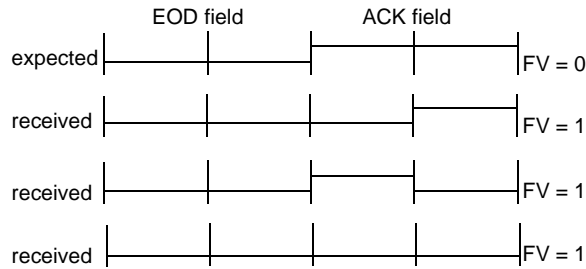

Interrupt Status Register (0x09)

7	6	5	4	3	2	1	0
RST	0	0	TE	TOK	RE	ROK	RNOK

- Read only register.
- Default value after reset: 0x80

RST: Reset interrupt

RE indicates that the circuit has detected a valid reset command via the $\overline{\text{RESET}}$ pin or the reset command bit GRES. This interrupt cannot be disabled, since its enable bit is set when a reset is detected.

TE: Transmit Error Status Flag (or Exceeded Retry)

This flag is set only when the Max number of transmission (1+MR [3:0]) is reached with error of transmission.

Figure 20. Exceeded retry with MR[3.0] = 3

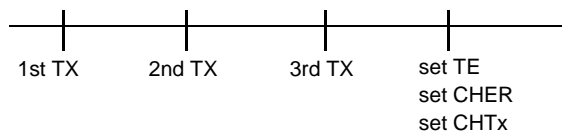

*TOK: Transmit OK
Status Flag*

*RE: Receive Error
Status Flag*

*ROK: Receive "with
RAK (RAK=1)" OK
Status Flag*

*RNOK: Receive "with no
RAK (RAK=0)" OK
Status Flag* *One: Status flag activated
Zero: No status flag.*

Interrupt Enable Register (0x0A)

7	6	5	4	3	2	1	0
1	0	0	TEE	TOKE	REE	ROKE	RNOKE

- Read/write register
- Default value reset: 0x80

Note: On reset the Reset Interrupt Enable bit is set to 1 instead of 0, as the general rule.

*TEE: Transmit Error
Enable*

*TOKE: Transmission OK
Enable*

*REE: Reception Error
Enable*

*ROKE: Reception "with
RAK" OK Enable*

*RNOKE: Reception "with no
RAK" OK
Enable* *One: IT enabled.
Zero: IT disabled.*

Interrupt Reset Register (0x0B)

7	6	5	4	3	2	1	0
RSTR	0	0	TER	TOKR	RER	ROKR	RNOKR

- Write only register.
- Reserved bit: 5 and 6. This bit cannot be set by user; a zero must always be written to this bit.

RSTR: Reset Interrupt
Reset

TER: Transmit Error
Status Flag Reset

TOKR: Transmit OK
Status Flag Reset

RER: Receive Error
Status Flag Reset

ROKR: Receive "with
RAK" OK Status Flag
Reset

RNOKR: Receive "with
no RAK" OK Status Flag
Reset

One: Status flag reset
Zero: Status flag unchanged

Figure 21. Update of the Status Register

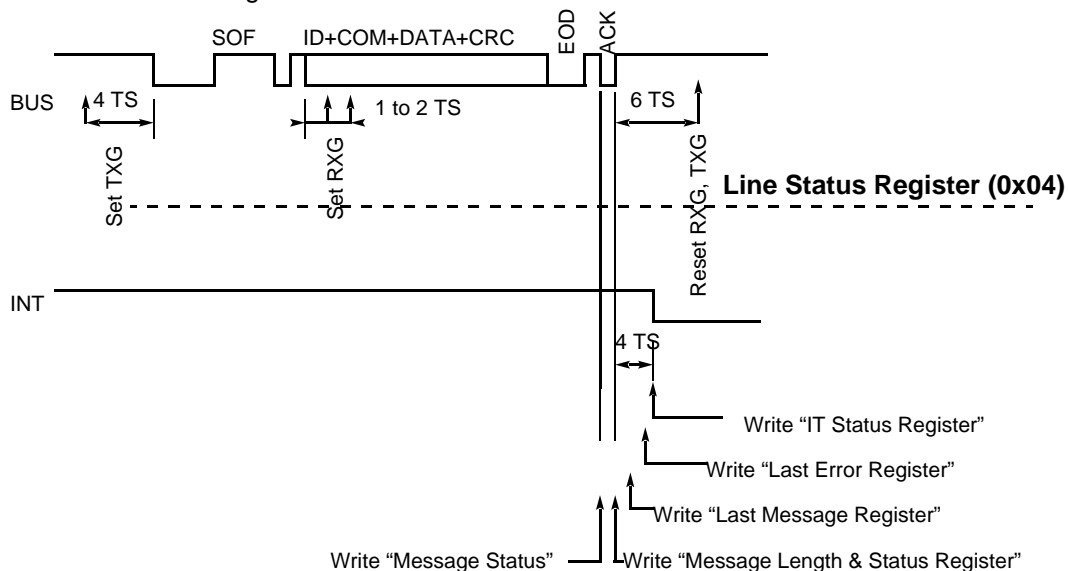

Channel Registers

There is a total of 14 channel register sets, each occupying 8 bytes for addressing simplicity, integrated into the circuit. Each set contains two 2 x 8-bit registers for the identifier tag, identifier mask and command fields plus two 1 x 8-bit registers for DMA pointers and message status.

The base_address of each set is: $(0x10 + [0x08 * channel_number])$.

When the TSS461F is reset either via the external reset pin or the general reset command, the channel registers are not affected. For example, on power-up of the circuit, all the channel registers start with random values.

Due to this fact, the user should take care to initialize all the channel registers before exiting from idle mode. The easiest way to disable a channel register is to set the received and transmitted bits to 1 in the Message Length & Status Register.

Table 9. Channel Register Sets Map

Channel Number	From	To	Channel Number	From	To
6	0x40	0x47	13	0x78	0x7F
5	0x38	0x3F	12	0x70	0x77
4	0x30	0x37	11	0x68	0x6F
3	0x28	0x2F	10	0x60	0x67
2	0x20	0x27	9	0x58	0x5F
1	0x18	0x1F	8	0x50	0x57
0	0x10	0x17	7	0x48	0x4F

Table 10. Channel Register Set Structure

Reg. Name	Offset	Bit 7	Bit 6	Bit 5	Bit 4	Bit 3	Bit 2	Bit 1	Bit 0
ID_MASK	0x07	ID_M [3:0]				x	x	x	x
ID_MASK	0x06	ID_M [11:4]							
(no register)	0x05	x	x	x	x	x	x	x	x
(no register)	0x04	x	x	x	x	x	x	x	x
MESS_L/ STA	0x03	M_L [4:0]					CHER	CHTx	CHRx
MESS_PTR	0x02	DRACK	M_P [6:0]						
ID_TAG/ CMD	0x01	ID_T [3: 0]				EXT	RAK	RNW	RTR
ID_TAG	0x00	ID_T [11:4]							

Identifier Tag and Command Registers

The identifier tag and command registers is located at the base_address and base_address + 1. It allows the user to specify the full 12-bit identifier field of the ISO standard and the 4-bit command.

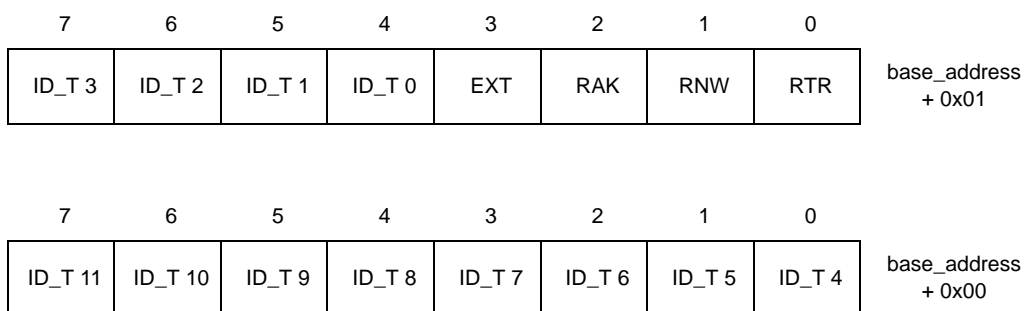

- Read/Write registers.

ID_T [11:0]: Identifier Tag

Upon a reception hit (i.e, a good comparison between the identifier received and an identifier specified, taking the comparison mask into account, as well as a status and command indicating a message to be received, the identifier tag bits value will be rewritten with the identifier bits actually received.

EXT, RAK, RNW & RTR: (See section "Retries, Rearbitrate and Abort")

No comparison will be done on the command bits, except on EXT bit. The RAK, RNW and RTR bits will be written into the first byte of the Message upon a reception hit.

The RNW and RTR bits, as well as the status bits in the length and status register, must be in a valid position for reception or transmission. If not, the message corresponding to this identifier is considered as inactive or invalid.

The way of knowing if an acknowledge sequence was requested or not is to check the first byte of the Message.

Message Pointer Register

The message pointer register at address (base_address + 0x02) is 8 bits wide. It indicates where, in the Message DATA RAM area, the message buffer is located.

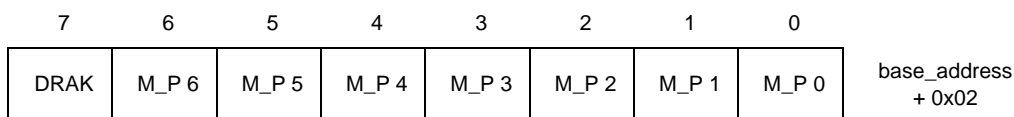

- Read/Write register

DRAK: Disable RAK (Used in 'Spy Mode')

In reception: whatever is the RAK bit of the incoming valid frame, no ACK answer will be set. If the message was successfully received, an IT is set (ROK or RNOK).

In transmission: no action.

One: disable active, 'spy' mode.

Zero: disable inactive, normal operation.

M_P [6:0]: Message Pointer

Since the Message DATA RAM area base address is 0x80, the value in this register is the offset from that address. If the message buffer length value is illegal (i.e. zero), this register is redefined as being a link pointer, thus containing the channel number of the channel that contains the actual message pointer, message length and received status. However, the identifier, mask, error and transmitted status used will be the originally matched channel. In any case, if a link is intended, the three high bits of M_P [6:0] should be set to 0.

This allows several channels to use the same actual reception buffer in Message DATA RAM, thus diminishing the memory usage.

Note that only 1 level of link is supported.

Message Length And Status Register

The message length and status register at address (base_address + 0x03) is also 8 bits wide. It indicates the length reserved for the message in the Message DATA RAM area.

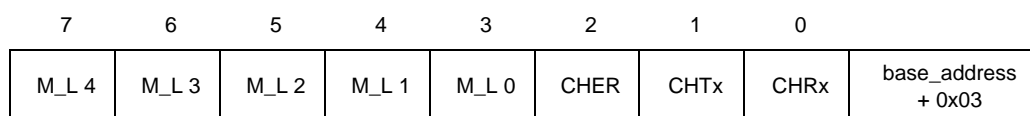

- Read/Write register.

M_L [4:0]: Message Length

The 5 high bits of this register allow the user to specify either the length of the message to be transmitted, or the maximum length of a message receivable in the pointed reception buffer.

Note, that the first byte in this register does not contain data, but the length of the message received. This implies that the length value has to be equal to or greater than the maximum length of a message to be received in this buffer (or the length of a message to be transmitted) plus 1. Thus allowing a maximum length of 30 bytes and a minimum length of 0 byte.

If the value of this field is "illegal" (i.e 0x00) then this message pointer is defined as being a link (see section "Message Pointer Register" and section "Linked Channels").

M_L [4:0] = 0x00	Linked channel
M_L [4:0] = 0x01	Frame with no DATA field (*)
M_L [4:0] = 0x02	Frame with 1 DATA byte
-----	-----
M_L [4:0] = 0x1D	Frame with 28 DATA bytes
M_L [4:0] = 0x1E	Frame with 29 DATA bytes
M_L [4:0] = 0x1F	Frame with 30 DATA bytes
(*) Different of a reply request frame with no in-frame reply (deferred reply).	

CHER: Channel Error Status and Abort Command

As status, this bit is set by the TSS461F when error occurs in transmission or on a received frame. The user must reset it.

To abort the transmission defined in the channel, this bit can be set to 1 by the user (see section "Retries, Rearbitrate and Abort" and section "Abort").

CHTx: Channel Transmitted and Transmit Enable Command

CHRx: Channel Received and Receive Enable Command

The two low order bits of this register contain the message status. Together with the RNW and RTR bits of the command register (base_address + 0x01), they define the message type of this channel (see section "Messages Types"). As a general rule (see section "Abort"), the status bits are only set by the TSS461F, so the user must reset them to perform a transmission (CHTx) or/and a reception (CHRx). The received and transmitted bits are only set if the corresponding frame is without errors or if the retry count has been exceeded.

Identifier Mask Registers

The Identifier Mask registers (base_address + 0x06 and base_address + 0x07) allow bitwise masking of the comparison between the identifier received and the identifier specified.

7	6	5	4	3	2	1	0
ID_M 3	ID_M 2	ID_M 1	ID_M 0	x	x	x	x

7	6	5	4	3	2	1	0
ID_M 11	ID_M 10	ID_M 9	ID_M 8	ID_M 7	ID_M 6	ID_M 5	ID_M 4

- Read/Write registers

ID_M [11:0]: Identifier Mask

A value of 1 indicates comparison enabled.
 A value of 0 indicates comparison disabled.

Mailbox

The mailbox contains all the messages received or to be transmitted. Each messages is link to a channel. The Mailbox RAM area has 128 bytes and is mapped from 0x80 to 0xFF (see section “Mapping”).

The message (or message buffer) is composed of:

- 1 byte of message status (only used in receiving)
- Bytes of data. These data are the bytes of the DATA field of the frame with the same organization.

The message is pointed by the Message Pointer Register of the channel, the length of the message is given by the Message Length & Status Register of the channel (section “Message Pointer Register” and section “Message Length And Status Register”). This area is a pure RAM, it contains a random value after reset.

Figure 22. Message Buffer Structure for Reception

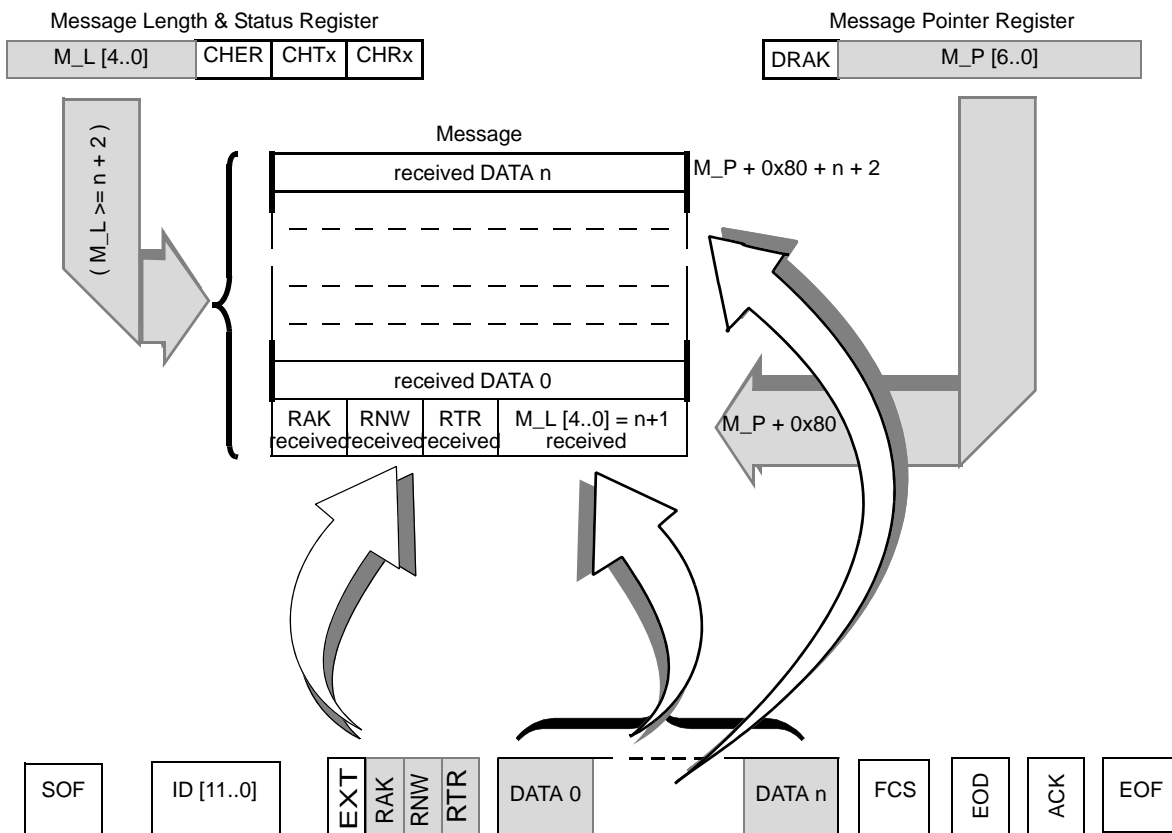

Note: Received DATA Frame, immediate or deferred reply

Figure 23. Message Buffer Structure for Transmission

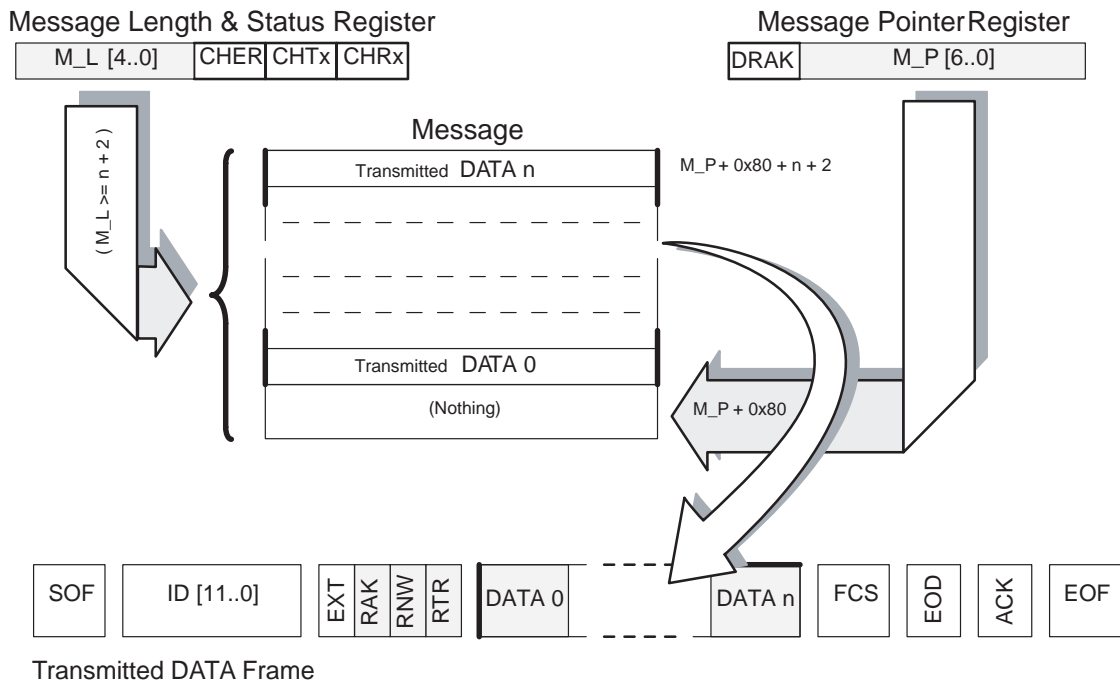

Message Status (Pointed by: Message Pointer Register)

7	6	5	4	3	2	1	0
RRAK	RRNW	RRTR	RM_L4	RM_L3	RM_L2	RM_L1	RM_L0

(no significant value in case of message to be transmitted)

RRAK: Received RAK Bit This bit is the RAK bit coming from the COM field of the received frame.

RRNW: Received RNW Bit This bit is the RNW bit coming from the COM field of the received frame.

RRTR: Received RTR Bit This bit is the RTR bit coming from the COM field of the received frame.

RM_L[4:0]: Message Length of the Received Frame If the DATA field of the received frame included DATA0 to DATAn, RM_L[4:0] = n+1, even if the reserved length (Message Length & Status Register) is larger.

Figure 24. Message Status Updating

Frame Type	Node x	Communication	Node A	Message Status on Node A after IT(*)			
Data Frame	I, P		C	RAK	RNW	RTR	length
Immediate Reply	I, C		P	RAK	RNW	RTR	previous value
Deferred Reply	I, C		P	RAK	RNW	RTR	previous value
Data Frame	C		I, P	previous values			
Immediate Reply	P		I, C	RAK	RNW	RTR	length
Deferred Reply	P		I, C	RAK	RNW	RTR	length

P: Producer I: Initiator C: Consumer

(*) After IT ROK or RNOK. In case of IT RE, the values can be erroneous.

Message Data (String Pointed by: Message Pointer Register + 1)



DATA0 is the first received (or transmitted) byte, DATAn is the last one.

- Notes:
1. If the length reserved (in the message length & status register) for an incoming frame is 2 bytes greater or more, the TSS461F will write the 2 bytes of the CRC field in the message string just after DATAn.
Because the VAN frame does not contain a message length, the only way for the component to know the length of the DATA field is either the message length register value, or the EOD field detection. When the reserved length is too large, at the moment when it detects the EOD, the TSS461F has already written the 2 bytes of the CRC field, considering these bytes as normal DATA.
 2. The Mailbox RAM area is a circular buffer. The next location after 0xFF is 0x80.

Messages Types

There are 5 basic message types defined in the TSS461F. Two of them (transmit and receive message types) correspond to the normal frame, and the rest correspond to the different versions of reply frames.

Transmit Message				
	RNW	RTR	CHTx	CHR _x
Initial Setup	0	0	0	Don't Care
After Transmission	0	0	1	Unchanged

To transmit a normal data frame on the VAN bus, the user must program an identifier as a Transmit Message. The TSS461F will then transmit this message on the bus until it has succeeded or the retry count is exceeded.

Receive Message				
	RNW	RTR	CHTx	CHR _x
Initial Setup	0	1	Don't Care	0
After Transmission	0	1	Unchanged	1

The opposite of the transmit message type is the Receive Message type. This message type will not generate any frames on the bus. Instead, it will listen to the bus until a frame passes that matches its identifier, with the mask taken into account, and then receive the data in that frame.

The data received will be stored in the message buffer and the length of the message received is stored in the first byte of the message buffer.

The actual identifier received is stored in the identifier register itself. This identifier may differ from the identifier specified in the register due to the effect of the mask register.

Normally, this should not interfere with the next identifier comparison since the bits that may differ are masked via the mask register.

Reply Request Message				
	RNW	RTR	CHTx	CHR _x
Initial Setup	1	1	0	0
After Transmission (Waiting for reply)	1	1	1	0
After Reception (of reply)	1	1	1	1

The Reply Request Message type is a demand to transmit on the VAN bus a reply request. When this message type is programmed, three things can happen.

First, no other modules on the bus responded with an in-frame reply, in this case the TSS461F will set the message type to the after transmission state. When this message type is programmed, the TSS461F will listen on the bus for a deferred reply frame matching this identifier, without transmitting the reply request.

Second, another module on the bus replies with an in-frame reply. In this case the message type will pass immediately into the after reception state, without passing the after transmission state.

Reply Request Message Without Transmission				
	RNW	RTR	CHTx	CHRx
Initial Setup	1	1	Don't Care	0
After Reception	1	1	Unchanged	1

Third, the TSS461F has not yet started to transmit the reply request, when another module either requests a reply, and gets it, or transmits a deferred reply. Warning! This should be avoided as it may result in an illegal message type (Illegal reply Request).

Immediate Reply Message				
	RNW	RTR	CHTx	CHRx
Initial Setup	1	0	0	0
After Transmission	1	0	1	1

The immediate Reply Message will attempt to transmit an in-frame reply, using the data in the message buffer. A deferred Reply Message is shown below.

Deferred Reply Message				
	RNW	RTR	CHTx	CHRx
Initial Setup	1	0	0	1
After Reception (of Reply Request)	1	0	1	1

This message type will immediately transmit a deferred reply frame.

Reply Request Detection Message				
	RNW	RTR	CHTx	CHRx
Initial Setup	1	0	1	0
After Reception	1	0	1	1

Finally, there is the Reply Request Detector Message type. Its purpose is to receive a reply request frame and notify the processor, without transmitting an in-frame reply.

Inactive Message				
	RNW	RTR	CHTx	CHRx
Recommended	Don't Care	Don't Care	1	1
After Transmission	0	0	1	Don't care
After Reception	0	1	Don't Care	1
Illegal Reply Request	1	1	0	1

The table above shows all inactive messages types. The last combination will transmit a reply request, but will not receive the reply since its buffer is tagged as occupied.





Priority Among the Different Channels

The priority handling on the VAN bus is already explained in the Line Interface section. The priorities for the messages in the TSS461F is, however, slightly different.

For instance, it's possible that an identifier matches two or more of the identifiers programmed into the registers. In this case, it is the lowest identifier number that has priority. i.e., if both identifier 5 and 10 match the identifier received, it is the identifier 5 that will receive the message.

However, since the identifier 5 will become an inactive message when it has received the frame, the next time the same identifier is seen on the bus, the corresponding data will be received by identifier 10.

The same is valid for messages to be transmitted, i.e., if two or more messages are ready to be transmitted, it is the one with the lowest identifier number that will get priority.

Retries, Rearbitrate and Abort

Retries and rearbitrate commands are located, in the Transmit Control Register and in the Command Register, respectively. An abort command is located in each channel register set, in the Message Length & Status Register (base_address + 0x03). These three commands are available only when the TSS461F is producer.

Figure 25. Transmit Function

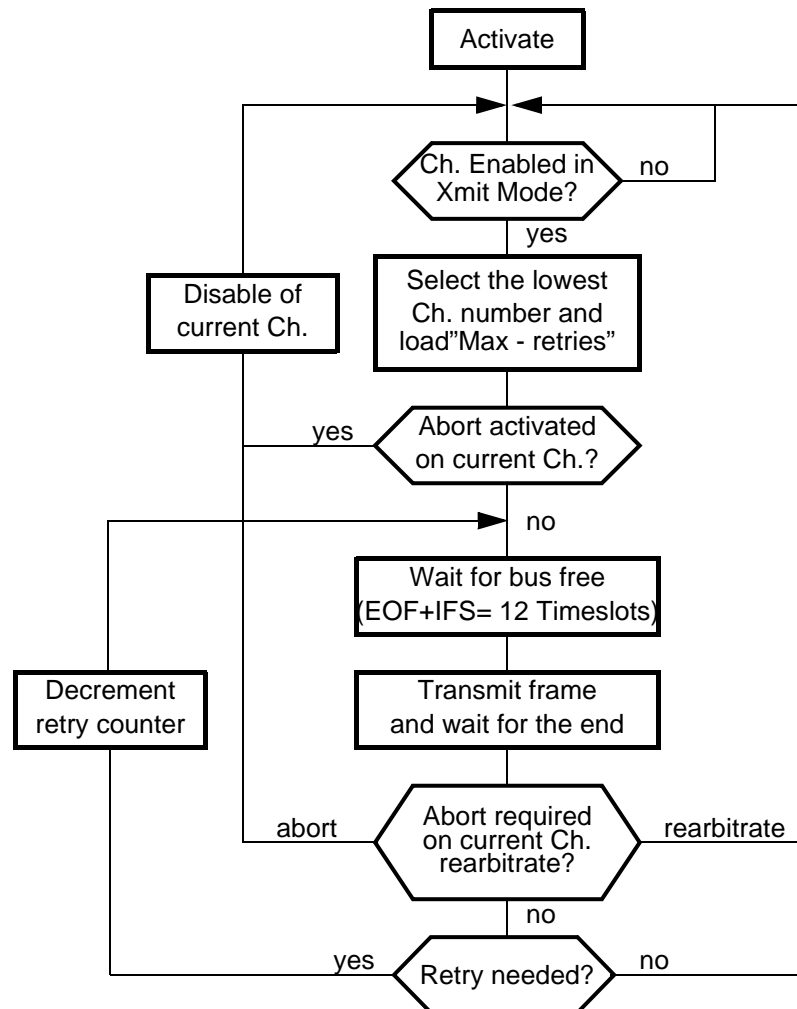

Retries

The purpose of retries feature is to provide, the capability of retrying a transmit request in case of failure, when a node tries to reach another node, either on normal DATA frame or on REPLY REQUEST frame.

The maximum of retries is programmable through MR[3:0] of the Transmit Control Register (0x01). When a channel is enable – bit CHTx= 0 of Message Length & Status Register, a 4-bit counter is loaded with MR[3:0]. At each attempt, this counter will be countdown. To 0, an IT TE is set in the Interrupt Status Register (0x09), and the transmission is stopped.

MR[3:0] = 1 indicates 1 retry, hence 2 transmission attempts will be performed (see Table 4). The number of retries performed, as well as the current channel number associated, can be read in the Transmission Status Register (0x05).

The Last Error Status Register (0x07) informs about the trouble encountered:

- Failure cases:- Code viol (CV error bit)
 - Acknowledge error (ACKE error bit)
 - CRC error (FCSE error bit)
- It should be noticed that contention is considered as normal CSMA/CD protocol and, therefore, is not taken into account in failure cases. So, an 'infinite' number of attempts can be performed if bus contention occurs continuously.

There is only one retries counter for all channels. When the user writes the Max_Retries value, all channels start their transmission with this parameter.

Rearbitrate

The purpose of rearbitrate feature is to postpone a channel already in transmission in order to authorize an higher priority (see section "Priority Among the Different Channels") message to be transmit.

Typical Example

- Max_retries = 1 (2 transmissions attempts).
- If Ch 8 is in a the retry loop and the user wants to transmit the Ch 5 without waiting the end of the loop, the user can use the rearbitrate command.
- Then, the TSS461F will wait the end of the current transmission, reload the retries counter and enable the Ch 5 to transmit.
- At the end of this transmission Ch5, either when the attempt is successful or either when the exceeded retry count is reached, the retries counter is reloaded and the transmission is activated for the Ch 8 again.

Figure 26. Rearbitrate Example

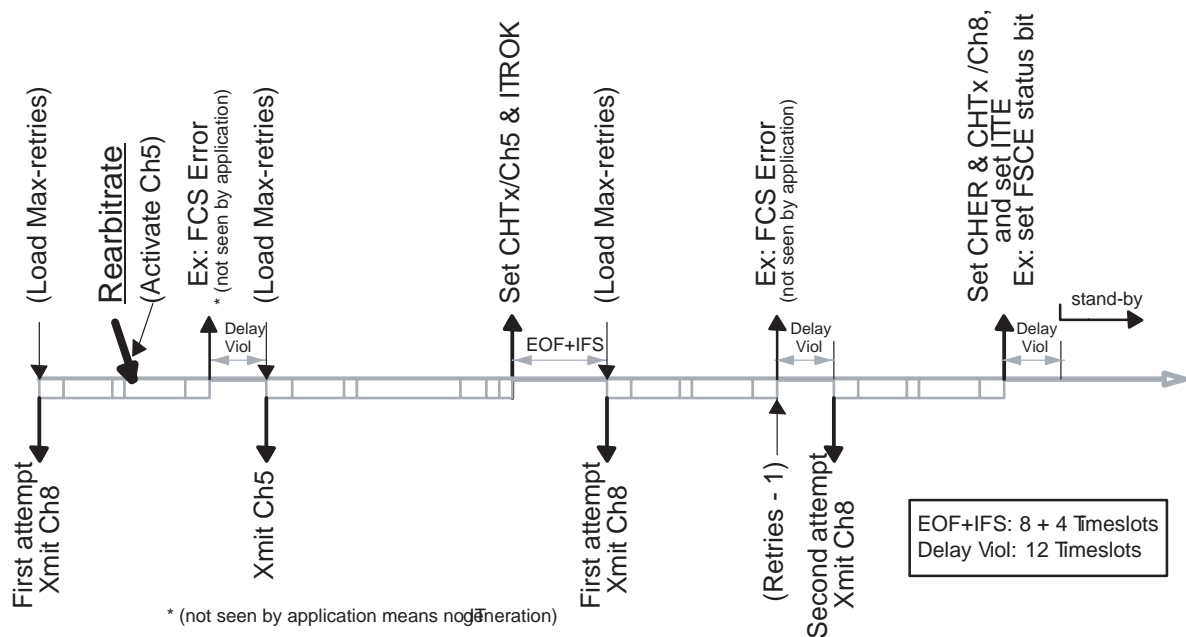
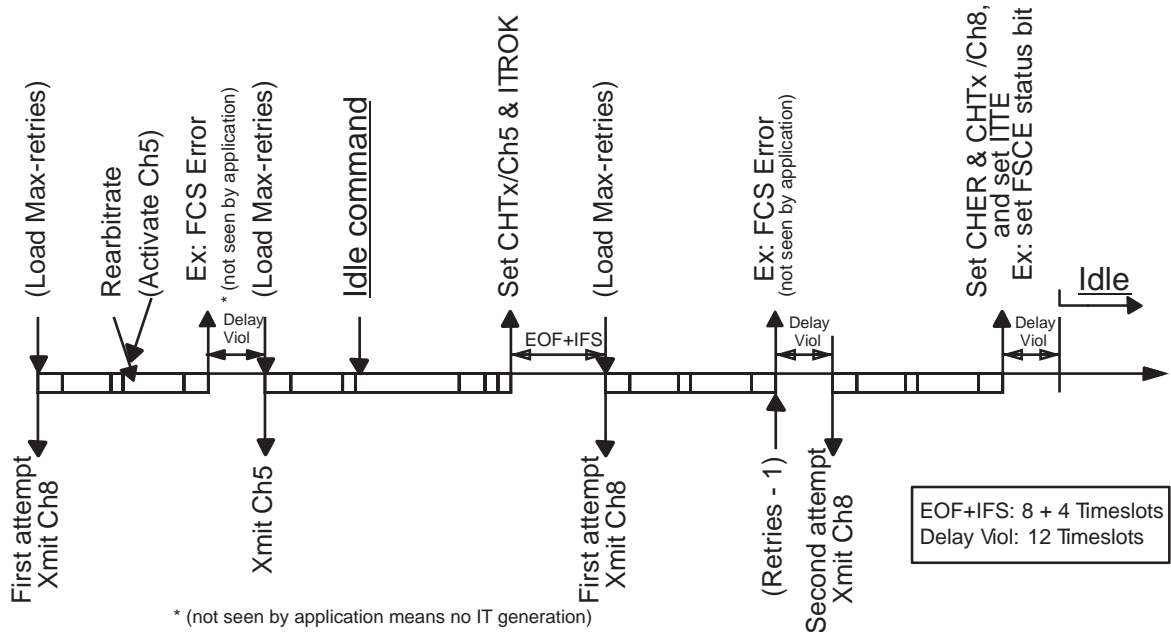

Figure 27. Idle and Rearbitrate Example



If the user sets the idle bit anywhere (after rearbitrate), the idle mode is entered only at the end of all the transmit attempts (for more information about idle command, see section “Activate, Idle and Sleep Modes”).

Disable Channel After Rearbitrate

Figure 28. Disable Channel After Rearbitrate Example

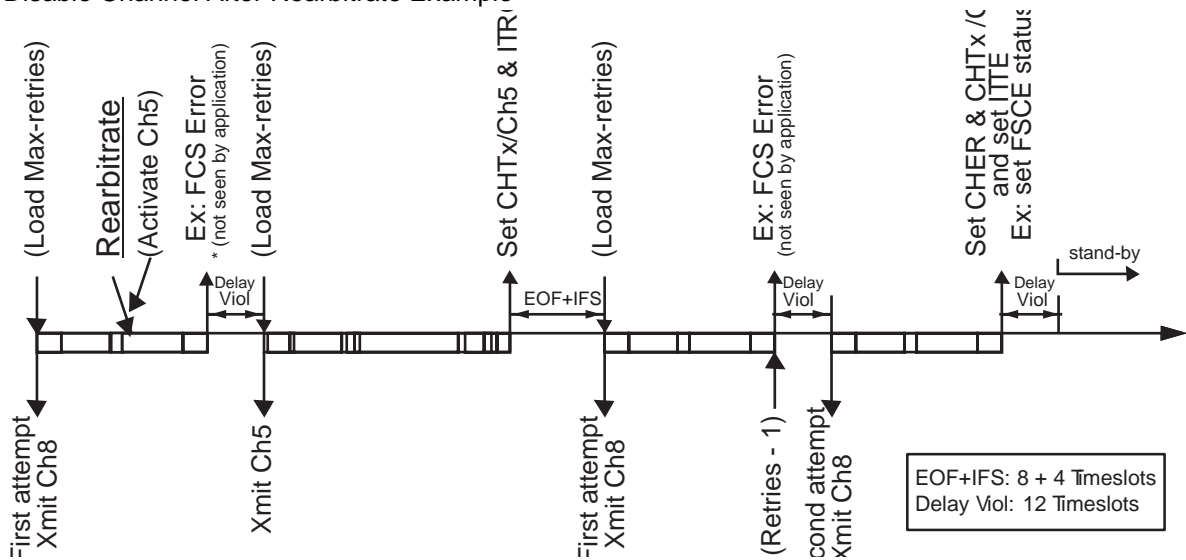

Note: In this case, the TSS461F completes the current attempt (Ch8) and lets the transmission go to the new channel (Ch5 if validated); otherwise, it stops all attempts on the current channel.

Abort

An abort command is dedicated to channels already enabled in transmission or in-frame response. For example, this command can be used to break the retry procedure on one channel.

Abort channel is done by setting the Error bit (CHER) in the Message Length & Status Register (base_address + 0x02). This command is taken into account if the channel aborted is not transmitted. When this abort command is really done, the TSS461F set to 1 the Transmitted bit (CHTx) of the Message Length & Status Register.

The abort mechanism is integrated into the transmit function. This means, abort, priority and retries live together in the transmit function.

Figure 29. Abort Example

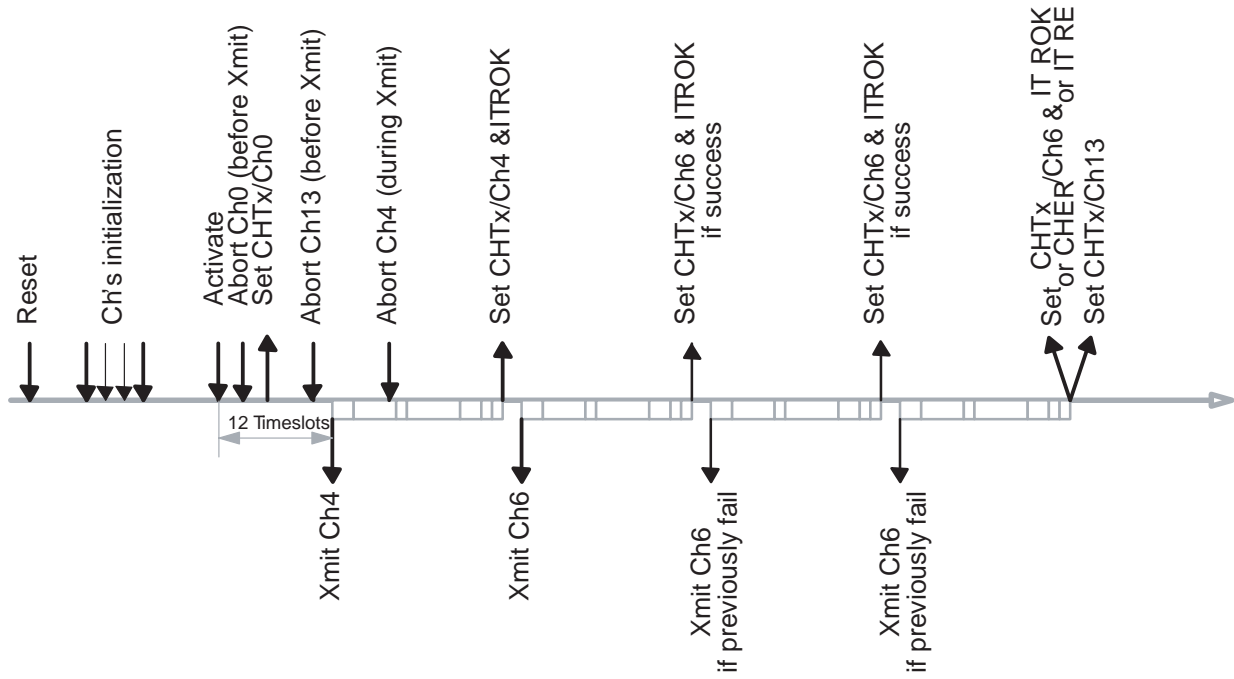

Activate, Idle and Sleep Modes

Sleep, idle and activate commands are located in the Command Register (0x03). These three commands are general commands for the TSS461F.

Idle and Activate Commands

After reset, the TSS461F starts in idle mode. In this mode, the oscillator operates (CKOUT pin active) but the circuit cannot transmit or receive anything on the VAN bus. The TxD output (pin 18) is in three-state mode, a pull-up resistor must be provided externally or by the line driver to avoid floating state on the VAN bus.

To activate the TSS461F, the user must set the activate bit (ACTI) and reset the idle bit (IDLE).

Figure 30. Idle and Activate Timings

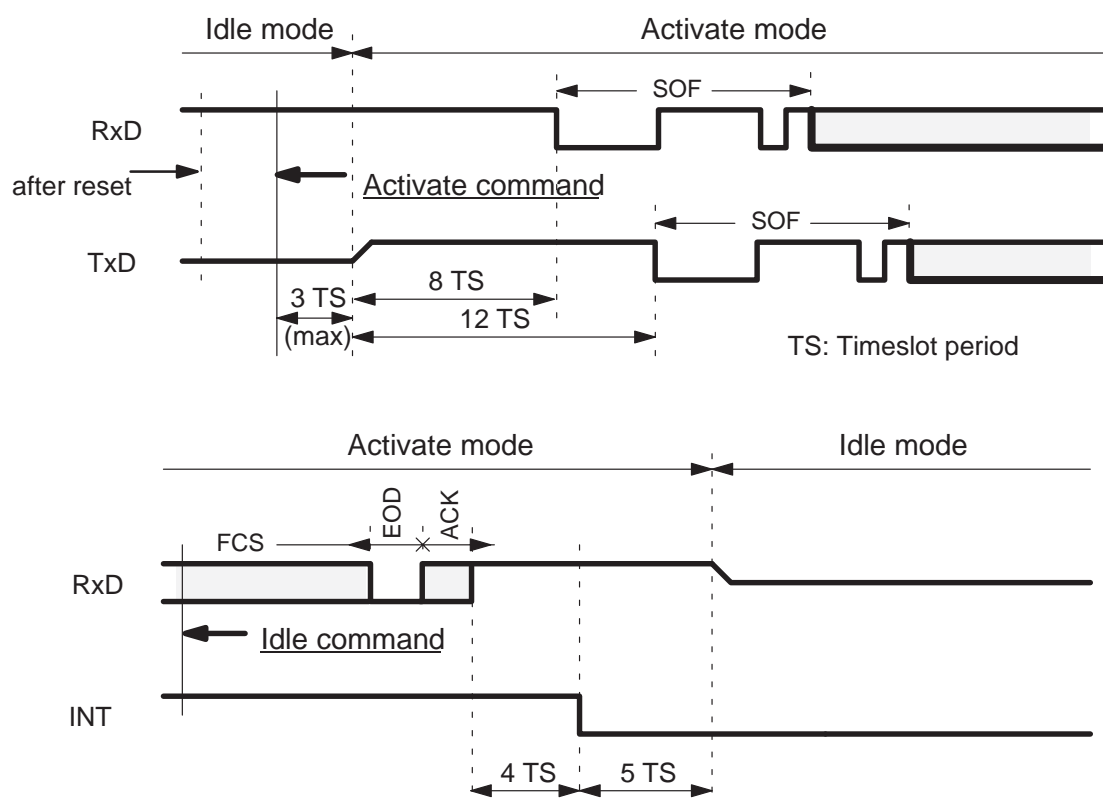

In both cases, the idle state can be verified by reading the Line Status register (0x04).

Sleep Command

If the user sets the sleep bit (SLEEP), the TSS461F enters in sleep mode, whatever are the values of activate and idle bits. All non-user registers are set-up to reduce the power consumption and the internal oscillator is immediately stopped. However, all user registers (accessible by μ P bus) are always available by the user

To exit from this mode, the user must set either the idle bit or the activate bit.

In a typical application (Figure 12) using the CKOUT feature (pin 12), if the TSS461F is put in sleep mode, the clock provided to the microcontroller is stopped. So, the system does not run and the only way to awake this application is an external reset.

Linked Channels

The linkage feature allows two channels to share the same Message area, the message pointer and the message length assumes the following property:

- Zero value as message length ($M_L [4:0] - \text{base_address} + 0x03$) declares the channel linked to another channel.
- The number of this other channel is defined in the message pointer field ($M_P [6:0] - \text{base_address} + 0x02$).
- The pointer and the length values for the Message area are defined only once time, in the register set of this other Channel.

Only one level of linkage can be created. For example, (see Figure 30) a Channel k can be linked to the Channel i but not to Channel j, already defined as linked to Channel i.

All the others can be different between the two channels, for example the ID_Tag.

Figure 31. Linkage Mechanism

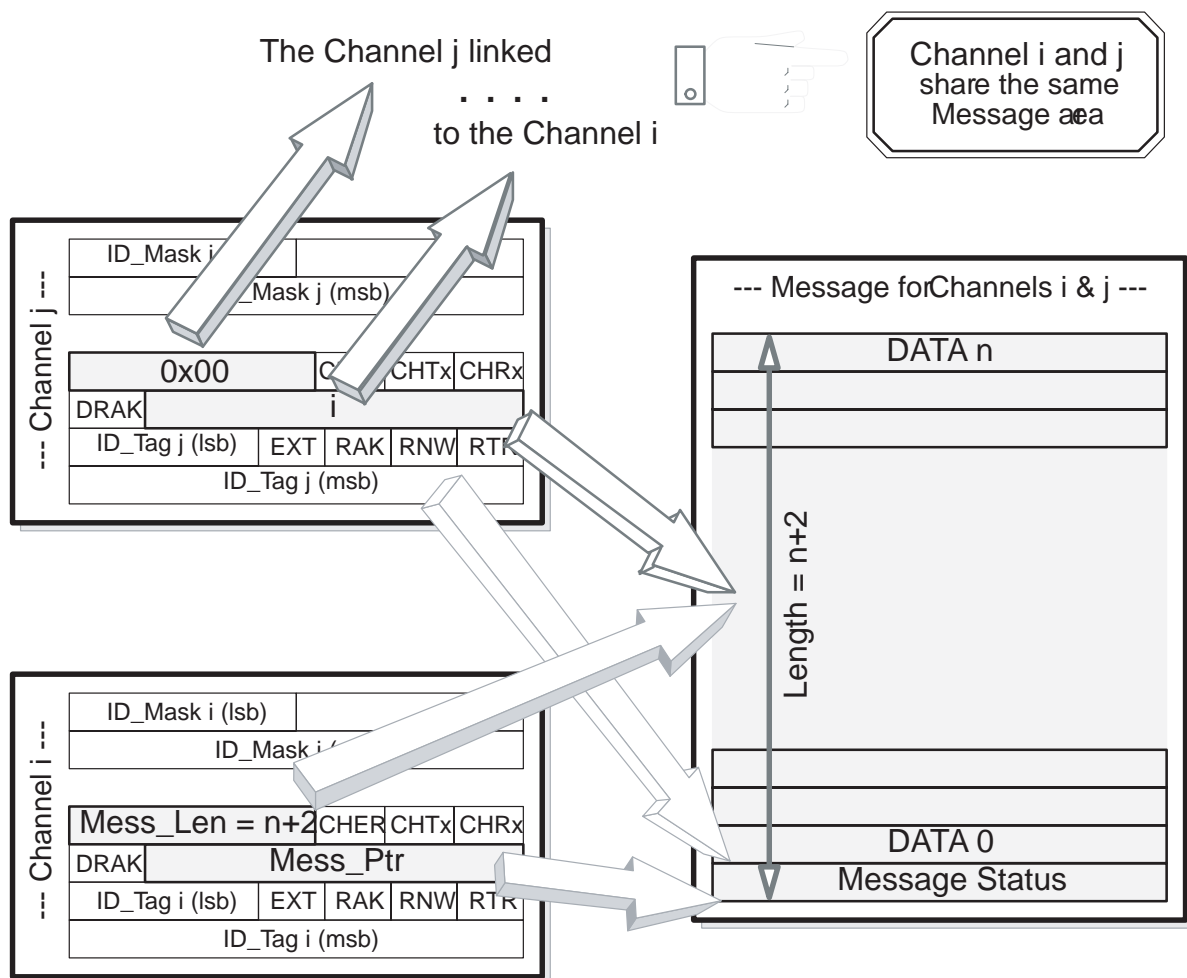

This Message Area sharing permits either optimizing the allocation of the 128 bytes of DATA, performing some special communications between the different nodes of the network.

Electrical Characteristics

Absolute Maximum Ratings

Ambient temperature under Bias:	
A = Automotive	-40°C to 125°C
Storage Temperature	-65°C to 150°C
Voltage on V_{CC} to V_{SS}	-0.5 to +7.0 V
Voltage on any Pin to V_{SS}	-0.5 V to $V_{CC} + 0.5$ V

Note: Stresses at or above those listed under "Absolute Maximum Ratings" may cause permanent damage to the device. This is a stress rating only and functional operation of the device at these or any other conditions exceeding those indicated in the operational sections of this specification is not implied. Exposure to absolute maximum rating conditions may affect device reliability.

DC Characteristics

$T_A = -40^\circ\text{C}$ to 125°C ; $V_{CC} = 5\text{ V} + 10\%$; $V_{SS} = 0\text{ V}$

Symbol	Parameter	Min	Max	Type	Test Conditions
V_{IL}	Input Low Voltage (except RESET and XTAL1)	-0.5	0.8	V	
V_{IH}	Input High Voltage (except RESET and XTAL1)	2.0	$V_{CC}+0.5$	V	
V_{IL1}	Input Low Voltage (RESET and XTAL1)	-0.5	$0.3 \cdot V_{CC}$	V	See Figure 2
V_{IH1}	Input High Voltage (RESET and XTAL1)	$0.7 V_{CC}$	$V_{CC}+0.5$	V	
V_{OL}	Output Low Voltage		0.4	V	$I_{OL} = 3.2\text{ mA}$, V_{CC} min
V_{OH}	Output High Voltage	2.4			$I_{OH} = -3.2\text{ mA}$, V_{CC} min
I_L	Input Leakage Current		± 5	μA	$0 < V_{IN} < V_{CC}$
R_{PD}	Input Pull-down Resistor	110		$\text{k}\Omega$	$0 < V_{IN} < V_{CC}$
C_{IO}	I/O Buffer Capacitance		10	pF	Not tested
I_{CCSB}	Power Supply Current Sleep Mode		50	μA	(Note 1)
I_{CCOP}	Power Supply Current Idle or Active Mode		4 15	mA mA	(Notes 2, 4) (Notes 3, 4)

- Notes:
1. Sleep Mode I_{CCSB} is measured according to Figure 40 with a V_{SS} Clock Signal.
 2. Active mode I_{CCOP} is measured at: XTAL = 1 MHz clock, VAN speed rate = 62.5 KTS/s.
 3. Active mode I_{CCOP} is measured at: XTAL = 16 MHz clock, VAN speed rate = 250 KTS/s.
 4. I_{CC} is a function of the Clock Frequency. Figure 8 displays a graph showing I_{CC} versus Clock frequency.
 5. RESET, RxD0, RxD1, RxD2 inputs.

Figure 32. I_{CC}

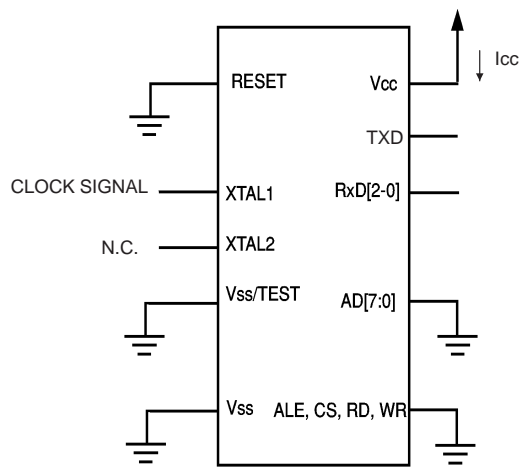
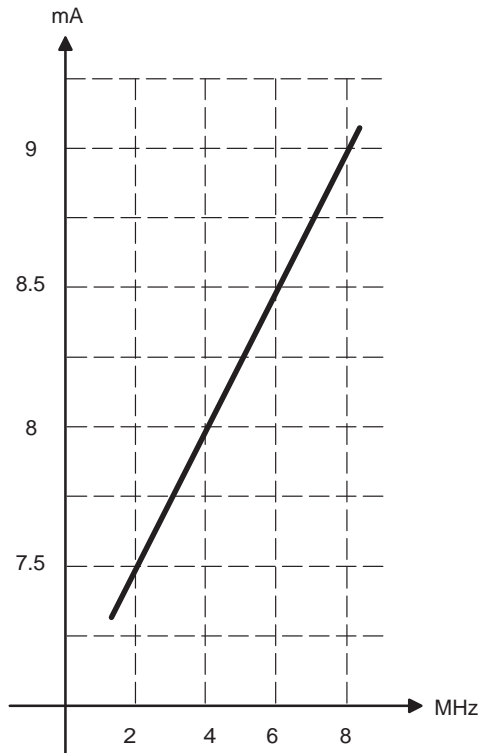

Figure 33. I_{CC} Versus Clock Frequency at 250 KTimeslot/s



AC Characteristics

Microprocessor Interface

TA = -40°C to 125°C; V_{CC} = 5V + 10%; V_{SS} = 0V

	Symbol	Characteristic	Min	Max	Unit
	T _{RESET}	RESET High Pulse Width (For Power-up Reset)	15		ns
1	T _{LHLL}	ALE High Pulse Width	10		ns
2	T _{AVLL}	Address Valid to ALE Low Setup Time	10		ns
3	T _{LLAX}	ALE Low to Address Invalid Hold Time	10		ns
4	T _{AVWL}	Address Valid to Command Active Time	20		ns
5	T _{DVWH}	Data Valid to Write Inactive Setup Time	10		ns
6	T _{WHDX}	Write Inactive to Data Invalid Hold Time	12		ns
7	T _{WHLH}	Write Inactive to ALE High Recovery Time	20		ns
8	T _{RLDV}	Read Active to Data Valid Access Time		110	ns
9	T _{RHDZ}	Read Inactive to Data Float Time		20	ns
10	T _{WHRLIZ}	Write Inactive or Read Active to IRQ Float Time		90	ns
11	T _{IZIL}	IRQ Float Pulse Width	2	20	ns

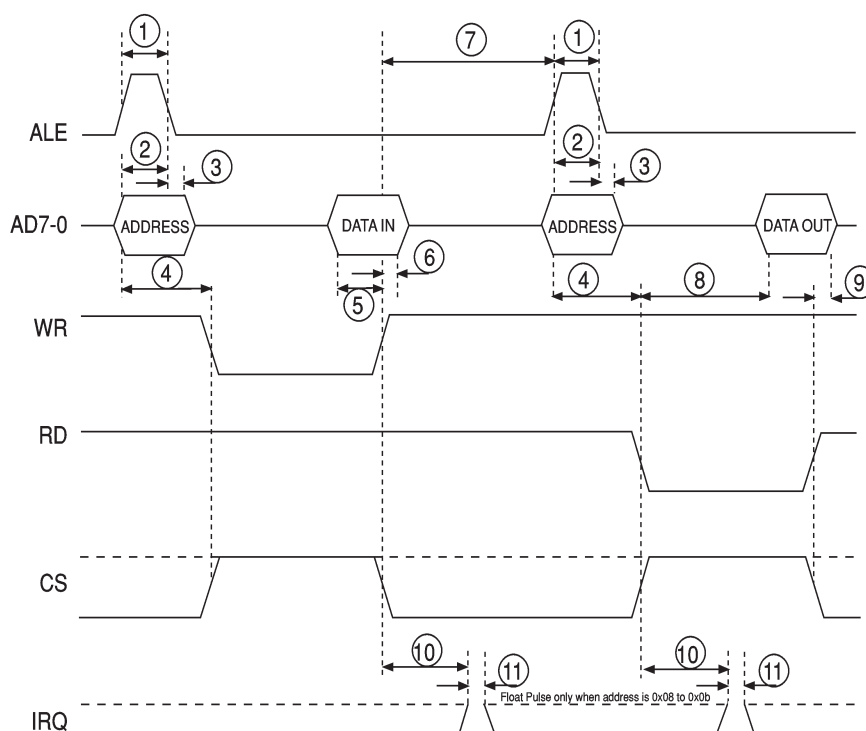

Oscillator Characteristics

Figure 34. C2 Versus Frequency

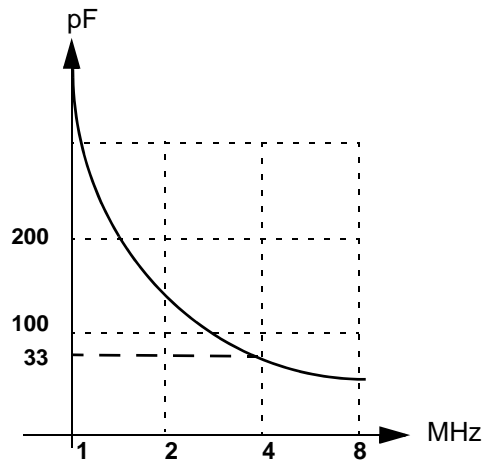

Note: C1 (no capacitance needed) see Figure 2.

External Clock Drive Characteristics (XTAL1)

Symbol	Parameter	Min	Max	Unit
T_{CHCH}	Oscillator Period	120		ns
T_{CHCX}	High Time	20		ns
T_{CLCX}	Low Time	20		ns
T_{CLCH}	Rise Time		20	ns
T_{CHCL}	Fall Time		20	ns

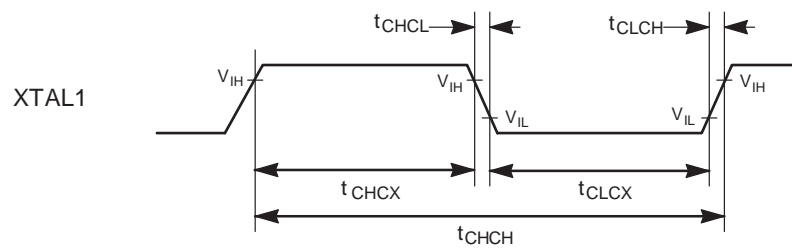

Packaging Information

SO 24

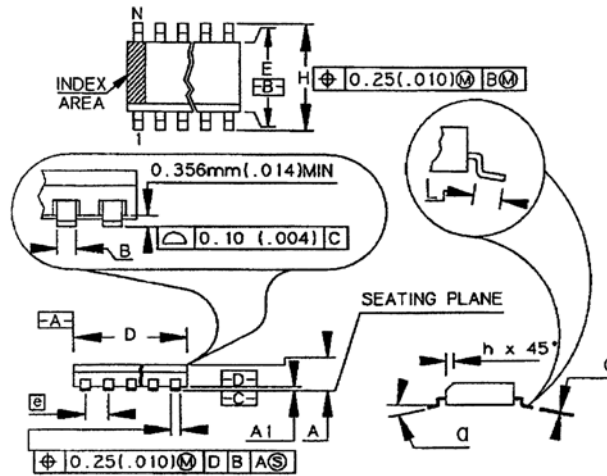

SO	MM		INCH	
A	2.35	2.65	0.093	0.104
A1	0.10	0.30	0.004	0.012
B	0.35	0.49	0.014	0.019
C	0.23	0.32	0.009	0.013
D	15.20	15.60	0.599	0.614
E	7.40	7.60	0.291	0.299
e	1.27	BSC	0.050	BSC
H	10.00	10.65	0.394	0.419
h	0.25	0.75	0.010	0.029
L	0.40	1.27	0.016	0.050
N	24		24	
a	0°		0°	



Ordering Information

Part Number	Supply Voltage	Temperature Range	Package	Packing
TSS461F-TDSA-9	5V \pm 10%	-40°C to +125°C	SO24	Tube
TSS461F-TDRA-9	5V \pm 10%	-40°C to +125°C	SO24	Tape & Reel
TSS461F-TDRZ-9 ⁽¹⁾	5V \pm 10%	-40°C to +125°C	SO24	Tape & Reel

Note: 1. These products are available in ROHS version.



Atmel Corporation

2325 Orchard Parkway
San Jose, CA 95131, USA
Tel: 1(408) 441-0311
Fax: 1(408) 487-2600

Regional Headquarters

Europe

Atmel Sarl
Route des Arsenaux 41
Case Postale 80
CH-1705 Fribourg
Switzerland
Tel: (41) 26-426-5555
Fax: (41) 26-426-5500

Asia

Room 1219
Chinachem Golden Plaza
77 Mody Road Tsimshatsui
East Kowloon
Hong Kong
Tel: (852) 2721-9778
Fax: (852) 2722-1369

Japan

9F, Tonetsu Shinkawa Bldg.
1-24-8 Shinkawa
Chuo-ku, Tokyo 104-0033
Japan
Tel: (81) 3-3523-3551
Fax: (81) 3-3523-7581

Atmel Operations

Memory

2325 Orchard Parkway
San Jose, CA 95131, USA
Tel: 1(408) 441-0311
Fax: 1(408) 436-4314

Microcontrollers

2325 Orchard Parkway
San Jose, CA 95131, USA
Tel: 1(408) 441-0311
Fax: 1(408) 436-4314

La Chantrerie
BP 70602
44306 Nantes Cedex 3, France
Tel: (33) 2-40-18-18-18
Fax: (33) 2-40-18-19-60

ASIC/ASSP/Smart Cards

Zone Industrielle
13106 Rousset Cedex, France
Tel: (33) 4-42-53-60-00
Fax: (33) 4-42-53-60-01

1150 East Cheyenne Mtn. Blvd.
Colorado Springs, CO 80906, USA
Tel: 1(719) 576-3300
Fax: 1(719) 540-1759

Scottish Enterprise Technology Park
Maxwell Building
East Kilbride G75 0QR, Scotland
Tel: (44) 1355-803-000
Fax: (44) 1355-242-743

RF/Automotive

Theresienstrasse 2
Postfach 3535
74025 Heilbronn, Germany
Tel: (49) 71-31-67-0
Fax: (49) 71-31-67-2340

1150 East Cheyenne Mtn. Blvd.
Colorado Springs, CO 80906, USA
Tel: 1(719) 576-3300
Fax: 1(719) 540-1759

Biometrics/Imaging/Hi-Rel MPU/ High Speed Converters/RF Datacom

Avenue de Rochepleine
BP 123
38521 Saint-Egreve Cedex, France
Tel: (33) 4-76-58-30-00
Fax: (33) 4-76-58-34-80

Literature Requests

www.atmel.com/literature

Disclaimer: The information in this document is provided in connection with Atmel products. No license, express or implied, by estoppel or otherwise, to any intellectual property right is granted by this document or in connection with the sale of Atmel products. **EXCEPT AS SET FORTH IN ATMEL'S TERMS AND CONDITIONS OF SALE LOCATED ON ATMEL'S WEB SITE, ATMEL ASSUMES NO LIABILITY WHATSOEVER AND DISCLAIMS ANY EXPRESS, IMPLIED OR STATUTORY WARRANTY RELATING TO ITS PRODUCTS INCLUDING, BUT NOT LIMITED TO, THE IMPLIED WARRANTY OF MERCHANTABILITY, FITNESS FOR A PARTICULAR PURPOSE, OR NON-INFRINGEMENT. IN NO EVENT SHALL ATMEL BE LIABLE FOR ANY DIRECT, INDIRECT, CONSEQUENTIAL, PUNITIVE, SPECIAL OR INCIDENTAL DAMAGES (INCLUDING, WITHOUT LIMITATION, DAMAGES FOR LOSS OF PROFITS, BUSINESS INTERRUPTION, OR LOSS OF INFORMATION) ARISING OUT OF THE USE OR INABILITY TO USE THIS DOCUMENT, EVEN IF ATMEL HAS BEEN ADVISED OF THE POSSIBILITY OF SUCH DAMAGES.** Atmel makes no representations or warranties with respect to the accuracy or completeness of the contents of this document and reserves the right to make changes to specifications and product descriptions at any time without notice. Atmel does not make any commitment to update the information contained herein. Unless specifically provided otherwise, Atmel products are not suitable for, and shall not be used in, automotive applications. Atmel's Atmel's products are not intended, authorized, or warranted for use as components in applications intended to support or sustain life.

© Atmel Corporation 2005. All rights reserved. Atmel®, logo and combinations thereof, are registered trademarks, and Everywhere You Are® are the trademarks of Atmel Corporation or its subsidiaries. Other terms and product names may be trademarks of others.



Printed on recycled paper.

7615A-AUTO-02/06