

Features

- Full Wave Current Sensing
- Compensated Mains Supply Variations
- Variable Soft Start or Load-current Sensing
- Voltage and Current Synchronization
- Switchable Automatic Retriggering
- Triggering Pulse Typically 125mA
- Internal Supply-voltage Monitoring
- Current Requirement $\leq 3\text{mA}$

Applications

- Low-cost Motor Control
- Domestic Appliance

1. Description

The Atmel® U2008B is designed as a phase-control circuit in bipolar technology. It enables load-current detection as well as mains-compensated phase control. Motor control with load-current feedback and overload protection are preferred applications.

Figure 1-1. Block Diagram with Typical Circuit: Load Current Sensing

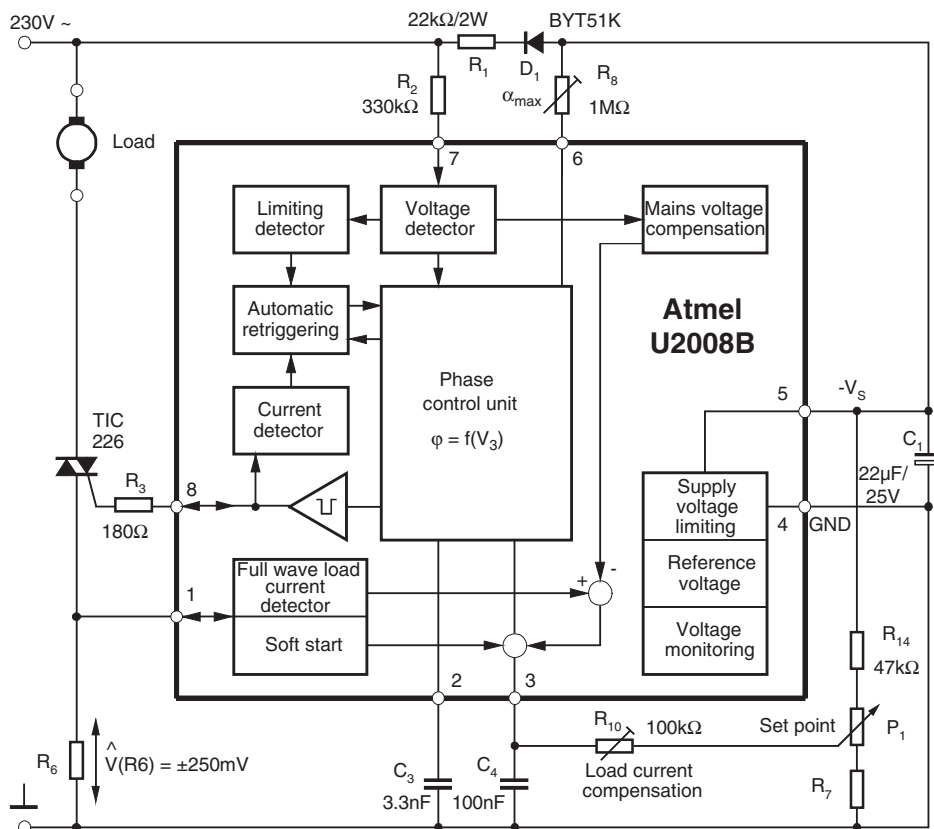

Low-cost Phase-control IC with Soft Start

Atmel U2008B



Figure 1-2. Block Diagram with Typical Circuit: Soft Start

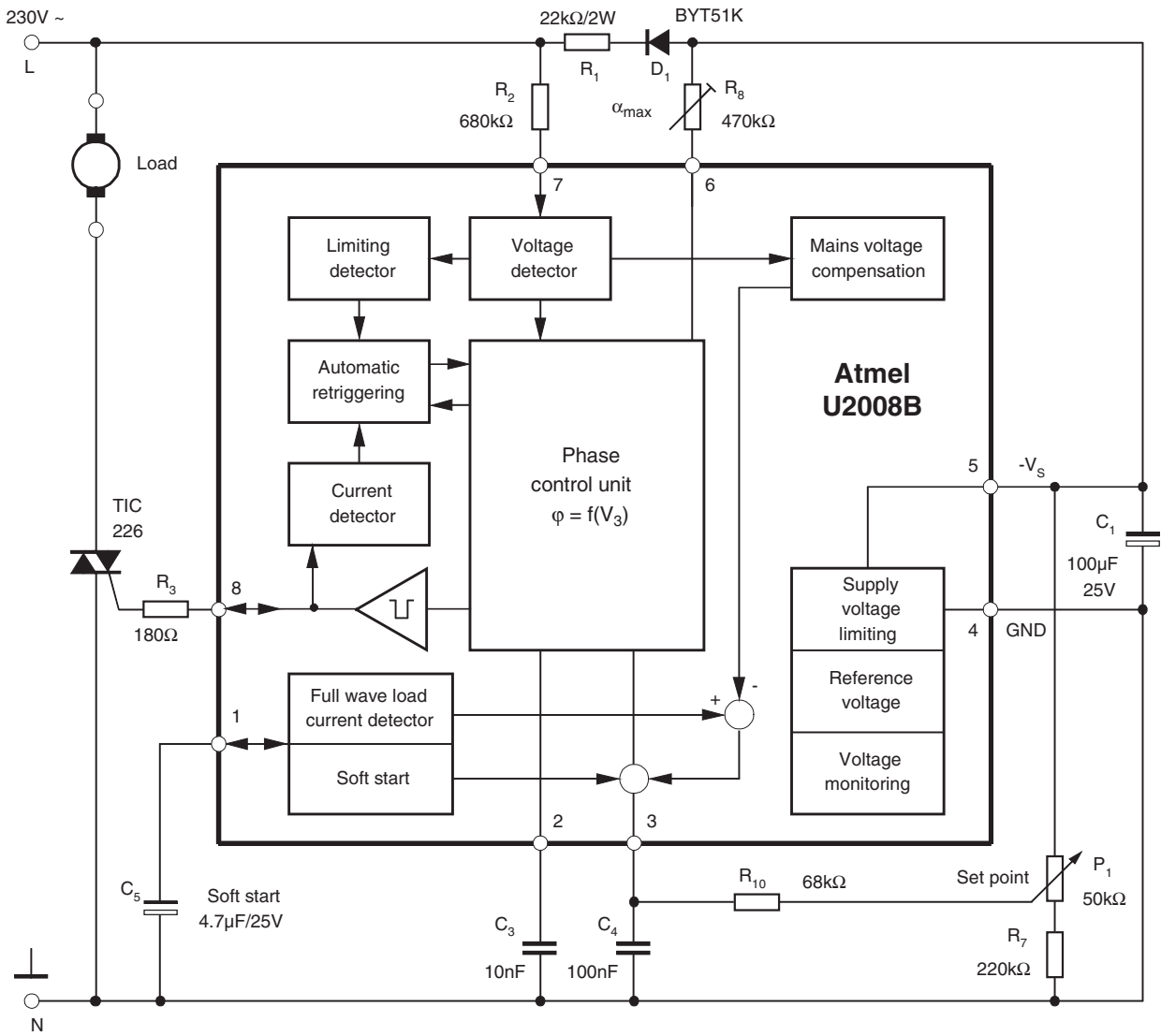

2. Pin Configuration

Figure 2-1. Pinning

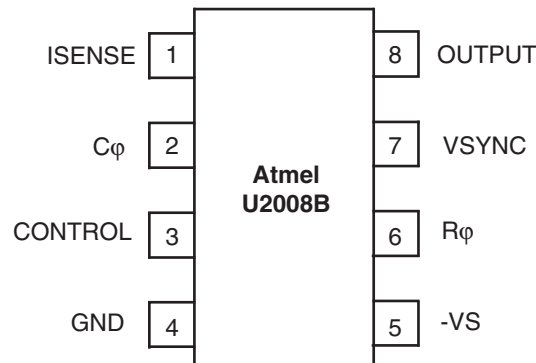

Table 2-1. Pin Description

Pin	Symbol	Function
1	ISENSE	Load current sensing
2	C ϕ	Ramp voltage
3	CONTROL	Control input/compensation output
4	GND	Ground
5	-VS	Supply voltage
6	R ϕ	Ramp current adjustment
7	VSYNC	Voltage synchronization
8	OUTPUT	Trigger output

2.1 Mains Supply, Pin 5

The Atmel® integrated circuit U2008B, which also contains voltage limiting, can be connected via D₁ and R₁ to the mains supply, see [Figure 1-2 on page 2](#). Supply voltage, between pin 4 (pos., ⊥) and pin 5, is smoothed by C₁.

The series resistance R₁ can be calculated as follows:

$$R_{1\max} = 0.85 \times \frac{V_M - V_{S\max}}{2 \times I_{\text{tot}}}$$

where:

- V_M = Mains voltage
- V_{Smax} = Maximum supply voltage
- I_{tot} = I_{Smax} + I_x = Total current compensation
- I_{Smax} = Maximum current consumption of the IC
- I_x = Current consumption of the external components

Operation with externally stabilized DC voltage is not recommended.

2.2 Voltage Monitoring

When the voltage is built up, uncontrolled output pulses are avoided by internal voltage monitoring. Apart from that, all latches of the circuit (phase control, load limit regulation) are reset and the soft start capacitor is short circuited. This guarantees a specified start-up behavior each time the supply voltage is switched on or after short interruptions of the mains supply. Soft start is initiated after the supply voltage has been built up. This behavior guarantees a gentle start-up for the motor and automatically ensures the optimum run-up time.

2.3 Phase Control, Pin 6

The function of the phase control is identical to that of the well-known Atmel® IC U211B. The phase angle of the trigger pulse is derived by comparing the ramp voltage V_2 at pin 2 with the set value on the control input, pin 3. The slope of the ramp is determined by C_3 and its charging current I_ϕ .

The charging current can be regulated, changed or altered using R_8 at pin 6.

The maximum phase angle, α_{\max} , (minimum current flow angle ϕ_{\min}) can also be adjusted by using R_8 (see [Figure 5-1 on page 7](#)).

When the potential on pin 2 reaches the set point level of pin 3, a trigger pulse is generated whose pulse width, t_p , is determined from the value of C_3 ($t_p = 9\mu\text{s}/\text{nF}$, [Figure 5-3 on page 8](#)). At the same time, a latch is set with the output pulse, as long as the automatic retriggering has not been activated, then no more pulses can be generated in that half cycle. Control input at pin 3 (with respect to pin 4) has an active range from -9V to -2V . When $V_3 = -9\text{V}$ the phase angle is at its maximum α_{\max} , i.e., the current flow angle is minimum. The minimum phase angle α_{\min} is set with $V_3 \geq -1\text{V}$.

2.4 Automatic Retriggering

The current-detector circuit monitors the state of the triac after triggering by measuring the voltage drop at the triac gate. A current flow through the triac is recognized when the voltage drop exceeds a threshold level of typically 40mV.

If the triac is quenched within the relevant half wave after triggering (for example owing to low load currents before or after the zero crossing of current wave, or for commutator motors, owing to brush lifters), the automatic retriggering circuit ensures immediate retriggering, if necessary with a high repetition rate, t_{pp}/t_p , until the triac remains reliably triggered.

2.5 Current Synchronization, Pin 8

Current synchronization fulfils two functions:

- Monitoring the current flow after triggering. In case the triac extinguishes again or it does not switch on, automatic triggering is activated as long as triggering is successful.
- Avoiding triggering due to inductive load. In the case of inductive load operation, the current synchronization ensures that in the new half wave no pulse is enabled as long as there is a current available from the previous half wave, which flows from the opposite polarity to the actual supply voltage.

A special feature of the IC is the realization of current synchronization. The device evaluates the voltage at the pulse output between the gate and reference electrode of the triac. This results in saving the separate current synchronization input with specified series resistance.

2.6 Voltage Synchronization with Mains Voltage Compensation, Pin 7

The voltage detector synchronizes the reference ramp with the mains supply voltage. At the same time, the mains-dependent input current at pin 7 is shaped and rectified internally. This current activates automatic retriggering and at the same time is available at pin 3 (Figure 5-5 on page 9). By suitable dimensioning, it is possible to attain the specified compensation effect. Automatic retriggering and mains voltage compensation are not activated until $|V_7 - V_4|$ increases to 8V. The resistance R_{sync} defines the width of the zero voltage cross-over pulse, synchronization current, and hence the mains supply voltage compensation current. If the mains voltage compensation and the automatic retriggering are not required, both functions can be suppressed by limiting $|V_7 - V_4| \leq 7V$ (see Figure 2-2).

Figure 2-2. Suppression of Automatic Retriggering and Mains Voltage Compensation

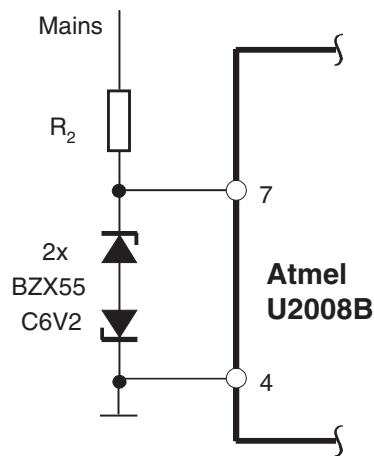

A further feature of the IC is the selection between soft start and load-current compensation. Soft start is possible by connecting a capacitor between pin 1 and pin 4 (Figure 5-4 on page 8). In the case of load-current compensation, pin 1 is directly connected with resistance R_6 , which is used for sensing load current.

2.7 Load Current Detection, Pin 1

The circuit continuously measures the load current as a voltage drop at resistor R_6 . The evaluation and use of both half waves results in a quick reaction to load-current change. Due to voltage at resistor R_6 , there is an increase of input current at pin 1. This current increase controls the internal current source, whose positive current values are available at pin 3 (see Figure 5-7 on page 9). The output current generated at pin 3 contains the difference from the load-current detection and the mains-voltage compensation (see Figure 5-5 on page 9).

The effective control voltage is the final current at pin 3 together with the desired value network. An increase of mains voltage causes an increase of the control angle α . An increase of load current results in a decrease of the control angle. This avoids a decrease in revolution by increasing the load as well as an increase of revolution by the increment of mains supply voltage.

3. Absolute Maximum Ratings

Reference point pin 4, unless otherwise specified

Parameters	Symbol	Value	Unit
Current limitation pin 5 $t \leq 10\mu\text{s}$	$-I_S$	30	mA
	$-i_S$	100	mA
Synchronous currents pin 7 $t \leq 10\mu\text{s}$	$\pm I_{\text{syncV}}$	5	mA
	$\pm i_{\text{syncV}}$	20	mA
Phase Control Pin 3			
Control voltage	$-V_I$	V_S to 0	V
Input current	$\pm I_I$	500	mA
Charge current pin 6	$-I_{\phi\text{max}}$	0.5	mA
Load Current Monitoring/Soft Start, Pin 1			
Input current	I_I	1	mA
Input voltage	V_I	$-V_S$ to +2	V
Pulse output			
Input voltage pin 8	$+V_I$	2	V
	$-V_I$	V_S	V
Storage temperature range	T_{stg}	-40 to +125	°C
Junction temperature range	T_J	-10 to +125	°C

4. Thermal Resistance

Parameters		Symbol	Value	Unit
Junction ambient	DIP8	R_{thJA}	110	K/W
	SO8 on p.c.	R_{thJA}	220	K/W
	So8 on ceramic	R_{thJA}	140	K/W

5. Electrical Characteristics

$V_S = -13\text{V}$, $T_{\text{amb}} = 25^\circ\text{C}$, reference point pin 4, unless otherwise specified

Parameters	Test Conditions	Symbol	Min.	Typ.	Max.	Unit
Supply (Pin 5)						
Supply-voltage limitation	$-I_S = 3.5\text{mA}$	$-V_S$	14.5		16.5	V
	$-I_S = 30\text{mA}$	$-V_S$	14.6		16.8	V
Current requirement	Pins 1, 4 and 7 open	$-I_S$			3.0	mA
Voltage Monitoring (Pin 5)						
Turn-on threshold		$-V_{\text{TON}}$		11.3	12.3	V
Phase Control						
Input current	Voltage sync. pin 7	$\pm I_{\text{syncV}}$		0.15	2	mA
	Current sync. pin 8	$\pm i_{\text{syncV}}$	3		30	μA
Voltage limitation	$\pm I_L = 2\text{mA}$ pin 7	$\pm V_{\text{syncV}}$	8.0	8.5	9.0	V
Reference Ramp (see Figure 5-1 on page 7)						
Charge current	Pin 7	I_ϕ	1		100	μA
Start voltage	Pin 2	$-V_{\text{max}}$	1.85	1.95	2.05	V

5. Electrical Characteristics (Continued)

$V_S = -13V$, $T_{amb} = 25^\circ C$, reference point pin 4, unless otherwise specified

Parameters	Test Conditions	Symbol	Min.	Typ.	Max.	Unit
Temperature coefficient of start voltage	Pin 2	$-TC_R$		-0.003		%/K
R_ϕ - reference voltage	$I_\phi = 10\mu A$, pins 6 to 5	$V_{R\phi}$	0.96	1.02	1.10	V
Temperature coefficient	$I_\phi = 10\mu A$, pin 6 $I_\phi = 1 A$	$TC_{VR\phi}$		0.03		%/K
		$TC_{VR\phi}$		0.06		%/K
Pulse Output (see Figure 5-2 on page 8) (Pin 8)						
Output-pulse current	$V_8 = -1.2$, $R_{GT} = 0\Omega$	I_0	100	125	150	mA
Output-pulse width	$C_3 = 3.3nF$, $V_S = V_{limit}$	t_p		30		μs
Automatic Retriggering (Pin 8)						
Turn-on threshold voltage		$\pm V_{ION}$	20		60	mV
Repetition rate	$I_7 \geq 150\mu A$	t_{pp}	3	5	7.5	t_p
Soft Start (see Figure 5-4 on page 8) (Pin 1)						
Starting current	$V_{1-4} = 8V$	I_0	5	10	15	μA
Final current	$V_{1-4} = -2V$	I_0	15	25	40	μA
Discharge current		$-I_0$	0.5			mA
Output current	Pin 3	$-I_0$	0.2		2	mA
Mains Voltage Compensation (see Figure 5-5 on page 9)						
Current transfer gain I_7/I_3	Pins 7, pin 3 Pins 1 and 2 open	G_i	14	17	20	
Reverse current	$V_{(R6)} = V_3 = V_7 = 0$, pin 3	$\pm I_R$			2	μA
Load-current Detection, $V_7 = 0$ (see Figure 5-7 on page 9)						
Transfer gain	I_3/V_1	G	0.28	0.32	0.37	$\mu A/mV$
Offset current	$V_1 = 0$, $V_3 = -8V$, pin 3	I_0	0	3	6	μA
Input voltage	Pin 1	$-V_1$	300		400	mV
Input offset voltage	Pin 1	$\pm V_0$			6	mV

Figure 5-1. Ramp Control

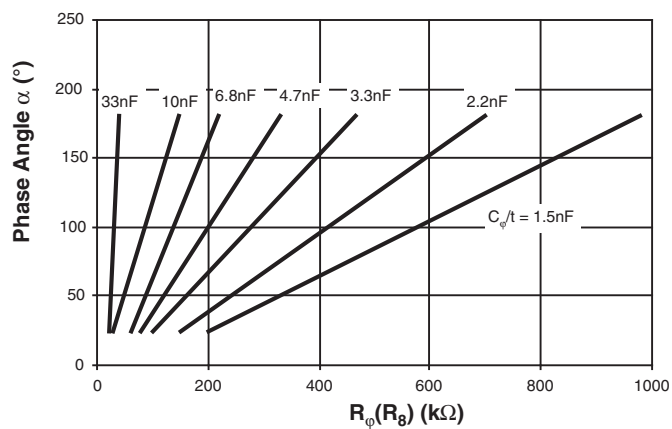

Figure 5-2. Pulse Output

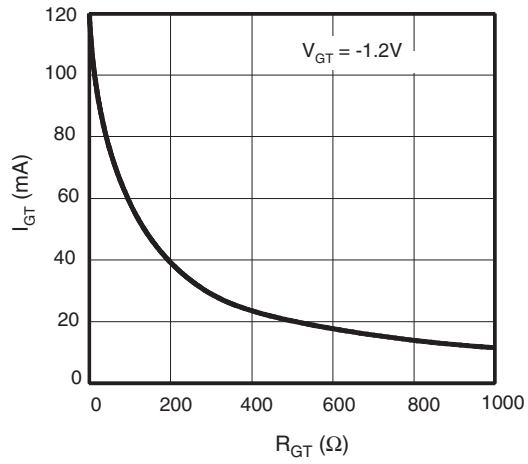

Figure 5-3. Output Pulse Width

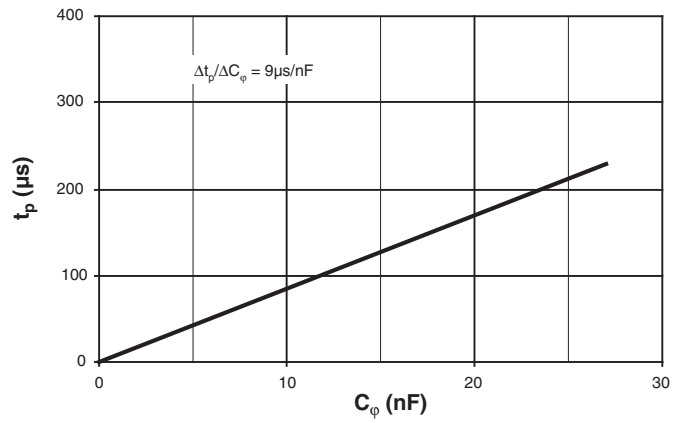

Figure 5-4. Option Soft Start

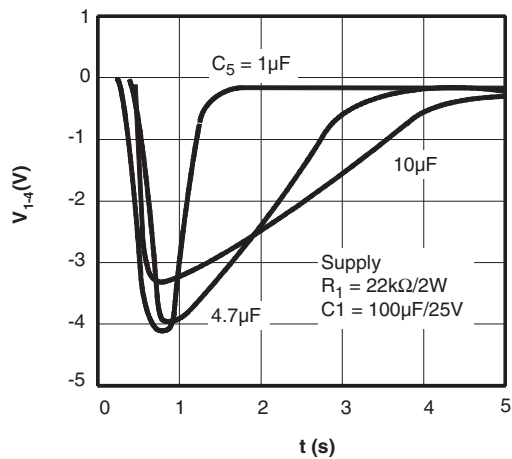

Figure 5-5. Mains Voltage Compensation

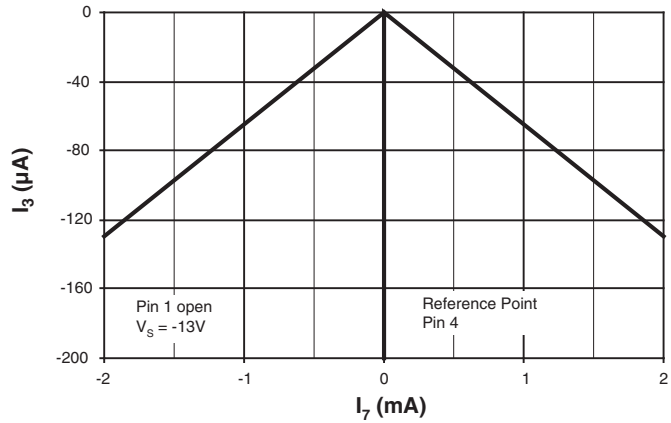

Figure 5-6. Maximum Resistance of R_1

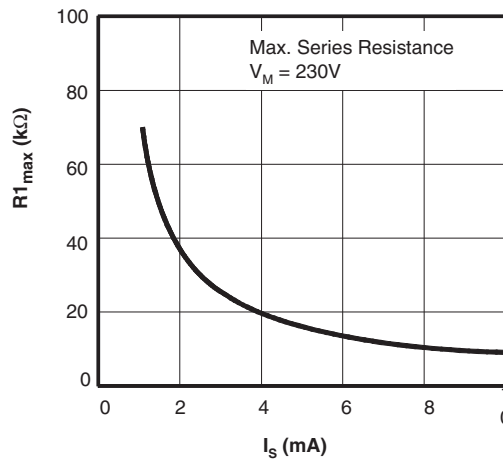

Figure 5-7. Load-current Detection

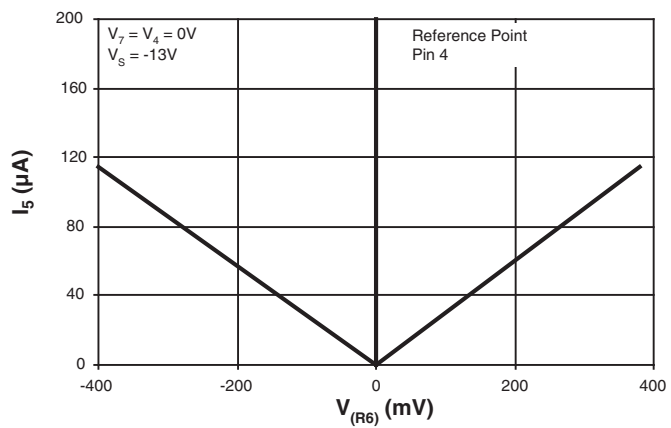

Figure 5-8. Power Dissipation of R_1

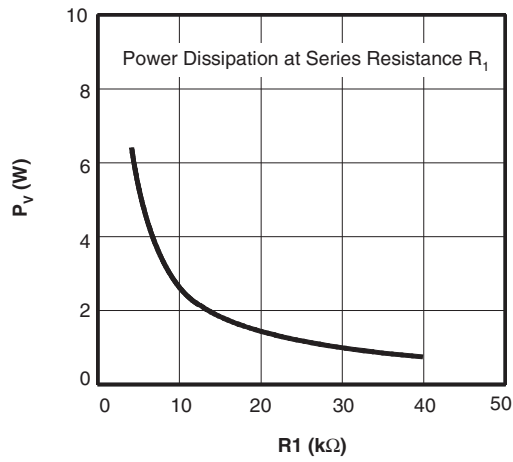
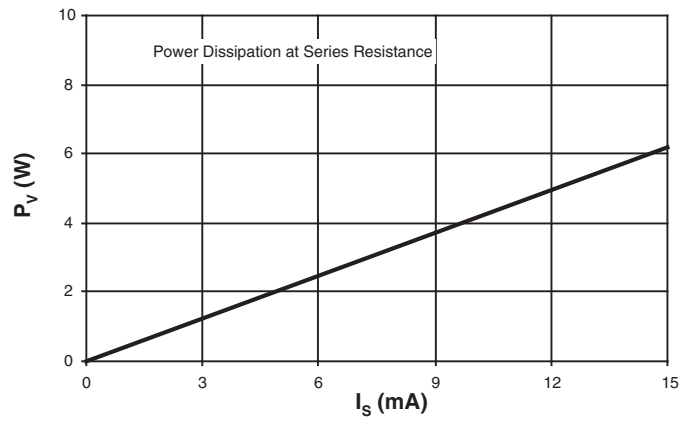

Figure 5-9. Power Dissipation of R_1 According to Current Consumption



6. Ordering Information

Extended Type Number	Package	Remarks
U2008B-MY	DIP8	Tube, Pb-free
U2008B-MFPY	SO8	Tube, Pb-free
U2008B-MFPG3Y	SO8	Taped and reeled, Pb-free

7. Package Information

Package: DIP8
Dimensions in mm

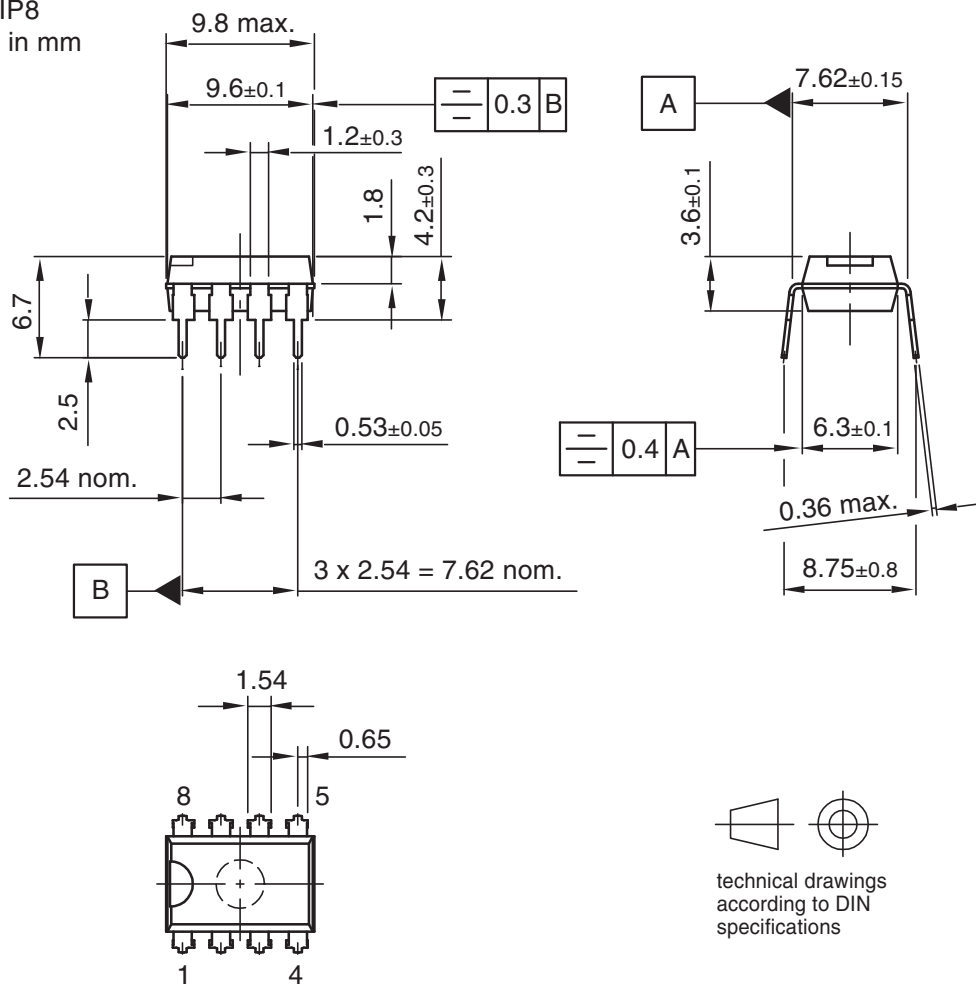

Drawing-No.: 6.543-5040.01-4

Issue: 1; 16.01.02

Package: SO 8

Dimensions in mm

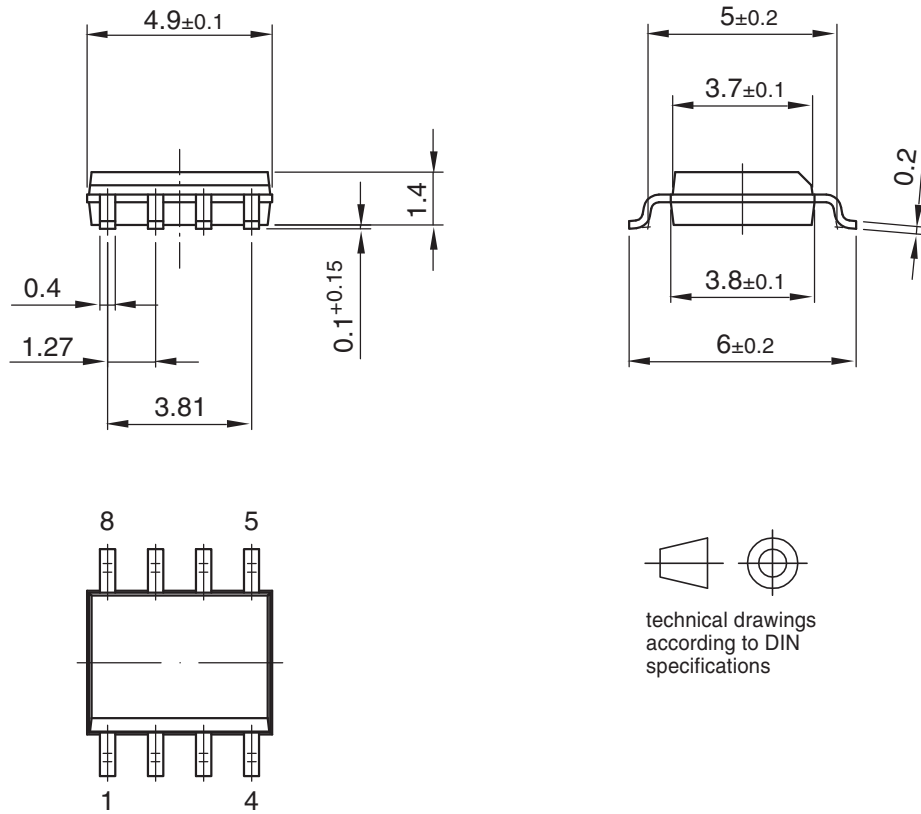

Drawing-No.: 6.541-5031.01-4

Issue: 1; 15.08.06

8. Revision History

Please note that the following page numbers referred to in this section refer to the specific revision mentioned, not to this document.

Revision No.	History
4712D-AUTO-03/11	<ul style="list-style-type: none">• Put datasheet in a new template• Page 6: Abs.Max.Ratings table: Change in heading• Page 6: El.Characteristics: Change in heading
4712C-AUTO-07/07	<ul style="list-style-type: none">• Put datasheet in a new template• Pb-free logo on page 1 deleted• Figure 5-5 “Mains Voltage Compensation” on page 9 changed• Figure 5-7 “Load-current Detection” on page 9 changed
4712B-AUTO-08/05	<ul style="list-style-type: none">• Put datasheet in a new template• First page: Pb-free logo added• Page 11: Ordering Information changed



Atmel Corporation

2325 Orchard Parkway
San Jose, CA 95131
USA

Tel: (+1)(408) 441-0311

Fax: (+1)(408) 487-2600

Atmel Asia Limited

Unit 01-5 & 16, 19/F
BEA Tower, Millennium City 5
418 Kwun Tong Road
Kwun Tong, Kowloon
HONG KONG

Tel: (+852) 2245-6100

Fax: (+852) 2722-1369

Atmel Munich GmbH

Business Campus
Parking 4
D-85748 Garching b. Munich
GERMANY

Tel: (+49) 89-31970-0

Fax: (+49) 89-3194621

Atmel Japan

9F, Tonetsu Shinkawa Bldg.
1-24-8 Shinkawa
Chuo-ku, Tokyo 104-0033
JAPAN

Tel: (+81) (3) 3523-3551

Fax: (+81) (3) 3523-7581

© 2011 Atmel Corporation. All rights reserved. / Rev.: 4712D-AUTO-03/11

Atmel®, Atmel logo and combinations thereof, and others are registered trademarks or trademarks of Atmel Corporation or its subsidiaries. Other terms and product names may be trademarks of others.

Disclaimer: The information in this document is provided in connection with Atmel products. No license, express or implied, by estoppel or otherwise, to any intellectual property right is granted by this document or in connection with the sale of Atmel products. EXCEPT AS SET FORTH IN THE ATMEL TERMS AND CONDITIONS OF SALES LOCATED ON THE ATMEL WEBSITE, ATMEL ASSUMES NO LIABILITY WHATSOEVER AND DISCLAIMS ANY EXPRESS, IMPLIED OR STATUTORY WARRANTY RELATING TO ITS PRODUCTS INCLUDING, BUT NOT LIMITED TO, THE IMPLIED WARRANTY OF MERCHANTABILITY, FITNESS FOR A PARTICULAR PURPOSE, OR NON-INFRINGEMENT. IN NO EVENT SHALL ATMEL BE LIABLE FOR ANY DIRECT, INDIRECT, CONSEQUENTIAL, PUNITIVE, SPECIAL OR INCIDENTAL DAMAGES (INCLUDING, WITHOUT LIMITATION, DAMAGES FOR LOSS AND PROFITS, BUSINESS INTERRUPTION, OR LOSS OF INFORMATION) ARISING OUT OF THE USE OR INABILITY TO USE THIS DOCUMENT, EVEN IF ATMEL HAS BEEN ADVISED OF THE POSSIBILITY OF SUCH DAMAGES. Atmel makes no representations or warranties with respect to the accuracy or completeness of the contents of this document and reserves the right to make changes to specifications and products descriptions at any time without notice. Atmel does not make any commitment to update the information contained herein. Unless specifically provided otherwise, Atmel products are not suitable for, and shall not be used in, automotive applications. Atmel products are not intended, authorized, or warranted for use as components in applications intended to support or sustain life.