



MICROCHIP

**EVB-KSZ9897
Gigabit Ethernet Switch
Evaluation Board
User's Guide**

Note the following details of the code protection feature on Microchip devices:

- Microchip products meet the specification contained in their particular Microchip Data Sheet.
- Microchip believes that its family of products is one of the most secure families of its kind on the market today, when used in the intended manner and under normal conditions.
- There are dishonest and possibly illegal methods used to breach the code protection feature. All of these methods, to our knowledge, require using the Microchip products in a manner outside the operating specifications contained in Microchip's Data Sheets. Most likely, the person doing so is engaged in theft of intellectual property.
- Microchip is willing to work with the customer who is concerned about the integrity of their code.
- Neither Microchip nor any other semiconductor manufacturer can guarantee the security of their code. Code protection does not mean that we are guaranteeing the product as "unbreakable."

Code protection is constantly evolving. We at Microchip are committed to continuously improving the code protection features of our products. Attempts to break Microchip's code protection feature may be a violation of the Digital Millennium Copyright Act. If such acts allow unauthorized access to your software or other copyrighted work, you may have a right to sue for relief under that Act.

Information contained in this publication regarding device applications and the like is provided only for your convenience and may be superseded by updates. It is your responsibility to ensure that your application meets with your specifications. MICROCHIP MAKES NO REPRESENTATIONS OR WARRANTIES OF ANY KIND WHETHER EXPRESS OR IMPLIED, WRITTEN OR ORAL, STATUTORY OR OTHERWISE, RELATED TO THE INFORMATION, INCLUDING BUT NOT LIMITED TO ITS CONDITION, QUALITY, PERFORMANCE, MERCHANTABILITY OR FITNESS FOR PURPOSE. Microchip disclaims all liability arising from this information and its use. Use of Microchip devices in life support and/or safety applications is entirely at the buyer's risk, and the buyer agrees to defend, indemnify and hold harmless Microchip from any and all damages, claims, suits, or expenses resulting from such use. No licenses are conveyed, implicitly or otherwise, under any Microchip intellectual property rights unless otherwise stated.

Trademarks

The Microchip name and logo, the Microchip logo, AnyRate, AVR, AVR logo, AVR Freaks, BeaconThings, BitCloud, CryptoMemory, CryptoRF, dsPIC, FlashFlex, flexPWR, Helder, JukeBlox, KEELOQ, KEELOQ logo, Kleer, LANCheck, LINK MD, maXStylus, maXTouch, MediaLB, megaAVR, MOST, MOST logo, MPLAB, OptoLyzer, PIC, picoPower, PICSTART, PIC32 logo, Prochip Designer, QTouch, RightTouch, SAM-BA, SpyNIC, SST, SST Logo, SuperFlash, tinyAVR, UNI/O, and XMEGA are registered trademarks of Microchip Technology Incorporated in the U.S.A. and other countries.

ClockWorks, The Embedded Control Solutions Company, EtherSynch, Hyper Speed Control, HyperLight Load, IntelliMOS, mTouch, Precision Edge, and Quiet-Wire are registered trademarks of Microchip Technology Incorporated in the U.S.A.

Adjacent Key Suppression, AKS, Analog-for-the-Digital Age, Any Capacitor, AnyIn, AnyOut, BodyCom, chipKIT, chipKIT logo, CodeGuard, CryptoAuthentication, CryptoCompanion, CryptoController, dsPICDEM, dsPICDEM.net, Dynamic Average Matching, DAM, ECAN, EtherGREEN, In-Circuit Serial Programming, ICSP, Inter-Chip Connectivity, JitterBlocker, KlearNet, KlearNet logo, Mindi, MiWi, motorBench, MPASM, MPF, MPLAB Certified logo, MPLIB, MPLINK, MultiTRAK, NetDetach, Omniscient Code Generation, PICDEM, PICDEM.net, PICkit, PICtail, PureSilicon, QMatrix, RightTouch logo, REAL ICE, Ripple Blocker, SAM-ICE, Serial Quad I/O, SMART-I.S., SQI, SuperSwitcher, SuperSwitcher II, Total Endurance, TSHARC, USBCheck, VariSense, ViewSpan, WiperLock, Wireless DNA, and ZENA are trademarks of Microchip Technology Incorporated in the U.S.A. and other countries.

SQTP is a service mark of Microchip Technology Incorporated in the U.S.A.

Silicon Storage Technology is a registered trademark of Microchip Technology Inc. in other countries.

GestIC is a registered trademark of Microchip Technology Germany II GmbH & Co. KG, a subsidiary of Microchip Technology Inc., in other countries.

All other trademarks mentioned herein are property of their respective companies.

© 2017, Microchip Technology Incorporated, All Rights Reserved.

ISBN: 978-1-5224-1527-5

**QUALITY MANAGEMENT SYSTEM
CERTIFIED BY DNV
= ISO/TS 16949 =**

Microchip received ISO/TS-16949:2009 certification for its worldwide headquarters, design and wafer fabrication facilities in Chandler and Tempe, Arizona; Gresham, Oregon and design centers in California and India. The Company's quality system processes and procedures are for its PIC® MCUs and dsPIC® DSCs, KEELOQ® code hopping devices, Serial EEPROMs, microperipherals, nonvolatile memory and analog products. In addition, Microchip's quality system for the design and manufacture of development systems is ISO 9001:2000 certified.

Object of Declaration: EVB-KSZ9897

EU Declaration of Conformity

This declaration of conformity is issued by the manufacturer.

The development/evaluation tool is designed to be used for research and development in a laboratory environment. This development/evaluation tool is not a Finished Appliance, nor is it intended for incorporation into Finished Appliances that are made commercially available as single functional units to end users under EU EMC Directive 2004/108/EC and as supported by the European Commission's Guide for the EMC Directive 2004/108/EC (8th February 2010).

This development/evaluation tool complies with EU RoHS2 Directive 2011/65/EU.

This development/evaluation tool, when incorporating wireless and radio-telecom functionality, is in compliance with the essential requirement and other relevant provisions of the R&TTE Directive 1999/5/EC and the FCC rules as stated in the declaration of conformity provided in the module datasheet and the module product page available at www.microchip.com. For information regarding the exclusive, limited warranties applicable to Microchip products, please see Microchip's standard terms and conditions of sale, which are printed on our sales documentation and available at www.microchip.com.

Signed for and on behalf of Microchip Technology Inc. at Chandler, Arizona, USA.

Derek Carlson

VP Development Tools

Date

NOTES:

Table of Contents

Preface	7
Introduction.....	7
Document Layout	7
Conventions Used in this Guide	8
The Microchip Web Site	9
Development Systems Customer Change Notification Service	9
Customer Support	9
Document Revision History	10
Chapter 1. Overview	
1.1 Introduction	11
1.2 References	12
1.3 Terms and Abbreviations	12
Chapter 2. Board Details & Configuration	
2.1 Power	13
2.1.1 +5V Power	13
2.2 Resets	13
2.2.1 Power-on Reset	13
2.3 Clock	13
2.4 Configuration	14
2.4.1 Switch Settings	15
2.4.2 Jumper Settings	15
2.4.3 SPI, I2C and MIIM Management	16
2.5 Using the EVB-KSZ9897	18
2.6 Mechanicals	18
Appendix A. EVB-KSZ9897 Evaluation Board	
A.1 Introduction	19
Appendix B. EVB-KSZ9897 Evaluation Board Schematics	
B.1 Introduction	21
Appendix C. Bill of Materials (BOM)	
C.1 Introduction	27
Worldwide Sales and Service	32

NOTES:

Preface

NOTICE TO CUSTOMERS

All documentation becomes dated, and this manual is no exception. Microchip tools and documentation are constantly evolving to meet customer needs, so some actual dialogs and/or tool descriptions may differ from those in this document. Please refer to our web site (www.microchip.com) to obtain the latest documentation available.

Documents are identified with a “DS” number. This number is located on the bottom of each page, in front of the page number. The numbering convention for the DS number is “DSXXXXA”, where “XXXX” is the document number and “A” is the revision level of the document.

For the most up-to-date information on development tools, see the MPLAB® IDE online help. Select the Help menu, and then Topics to open a list of available online help files.

INTRODUCTION

This chapter contains general information that will be useful to know before using EVB-KSZ9897. Items discussed in this chapter include:

- [Document Layout](#)
- [Conventions Used in this Guide](#)
- [The Microchip Web Site](#)
- [Development Systems Customer Change Notification Service](#)
- [Customer Support](#)
- [Document Revision History](#)

DOCUMENT LAYOUT

This document describes how to use the EVB-KSZ9897 as a development tool for the Microchip EVB-KSZ9897 gigabit Ethernet switch. The manual layout is as follows:

- **Chapter 1. “Overview”** – Shows a brief description of the EVB-KSZ9897.
- **Chapter 2. “Board Details & Configuration”** – Includes details and instructions for using the EVB-KSZ9897.
- **Appendix A. “EVB-KSZ9897 Evaluation Board”** – This appendix shows the EVB-KSZ9897.
- **Appendix B. “EVB-KSZ9897 Evaluation Board Schematics”** – This appendix shows the EVB-KSZ9897 schematics.
- **Appendix C. “Bill of Materials (BOM)”** – This appendix includes the EVB-KSZ9897 Bill of Materials (BOM).

CONVENTIONS USED IN THIS GUIDE

This manual uses the following documentation conventions:

DOCUMENTATION CONVENTIONS

Description	Represents	Examples
Arial font:		
Italic characters	Referenced books	<i>MPLAB® IDE User's Guide</i>
	Emphasized text	...is the <i>only</i> compiler...
Initial caps	A window	the Output window
	A dialog	the Settings dialog
	A menu selection	select Enable Programmer
Quotes	A field name in a window or dialog	"Save project before build"
Underlined, italic text with right angle bracket	A menu path	<u>File</u> > <i>Save</i>
Bold characters	A dialog button	Click OK
	A tab	Click the Power tab
N'Rnnnn	A number in verilog format, where N is the total number of digits, R is the radix and n is a digit.	4'b0010, 2'hF1
Text in angle brackets < >	A key on the keyboard	Press <Enter>, <F1>
Courier New font:		
Plain Courier New	Sample source code	#define START
	Filenames	autoexec.bat
	File paths	c:\mcc18\h
	Keywords	_asm, _endasm, static
	Command-line options	-Opa+, -Opa-
	Bit values	0, 1
	Constants	0xFF, 'A'
Italic Courier New	A variable argument	<i>file.o</i> , where <i>file</i> can be any valid filename
Square brackets []	Optional arguments	mcc18 [options] <i>file</i> [options]
Curly brackets and pipe character: { }	Choice of mutually exclusive arguments; an OR selection	errorlevel {0 1}
Ellipses...	Replaces repeated text	var_name [, var_name...]
	Represents code supplied by user	void main (void) { ... }

THE MICROCHIP WEB SITE

Microchip provides online support via our web site at www.microchip.com. This web site is used as a means to make files and information easily available to customers. Accessible by using your favorite Internet browser, the web site contains the following information:

- **Product Support** – Data sheets and errata, application notes and sample programs, design resources, user's guides and hardware support documents, latest software releases and archived software
- **General Technical Support** – Frequently Asked Questions (FAQs), technical support requests, online discussion groups, Microchip consultant program member listing
- **Business of Microchip** – Product selector and ordering guides, latest Microchip press releases, listing of seminars and events, listings of Microchip sales offices, distributors and factory representatives

DEVELOPMENT SYSTEMS CUSTOMER CHANGE NOTIFICATION SERVICE

Microchip's customer notification service helps keep customers current on Microchip products. Subscribers will receive e-mail notification whenever there are changes, updates, revisions or errata related to a specified product family or development tool of interest.

To register, access the Microchip web site at www.microchip.com, click on Customer Change Notification and follow the registration instructions.

The Development Systems product group categories are:

- **Compilers** – The latest information on Microchip C compilers, assemblers, linkers and other language tools. These include all MPLAB C compilers; all MPLAB assemblers (including MPASM assembler); all MPLAB linkers (including MPLINK object linker); and all MPLAB librarians (including MPLIB object librarian).
- **Emulators** – The latest information on Microchip in-circuit emulators. This includes the MPLAB REAL ICE and MPLAB ICE 2000 in-circuit emulators.
- **In-Circuit Debuggers** – The latest information on the Microchip in-circuit debuggers. This includes MPLAB ICD 3 in-circuit debuggers and PICkit 3 debug express.
- **MPLAB IDE** – The latest information on Microchip MPLAB IDE, the Windows Integrated Development Environment for development systems tools. This list is focused on the MPLAB IDE, MPLAB IDE Project Manager, MPLAB Editor and MPLAB SIM simulator, as well as general editing and debugging features.
- **Programmers** – The latest information on Microchip programmers. These include production programmers such as MPLAB REAL ICE in-circuit emulator, MPLAB ICD 3 in-circuit debugger and MPLAB PM3 device programmers. Also included are nonproduction development programmers such as PICSTART Plus and PIC-kit 2 and 3.

CUSTOMER SUPPORT

Users of Microchip products can receive assistance through several channels:

- Distributor or Representative
- Local Sales Office
- Field Application Engineer (FAE)
- Technical Support

Customers should contact their distributor, representative or field application engineer (FAE) for support. Local sales offices are also available to help customers. A listing of sales offices and locations is included in the back of this document.

Technical support is available through the web site at:
<http://www.microchip.com/support>

DOCUMENT REVISION HISTORY

Revision A (March 2017)

- Initial Release of this Document.

Chapter 1. Overview

1.1 INTRODUCTION

The EVB-KSZ9897 evaluation board features three Gigabit Ethernet products, KSZ9897R, KSZ9031RNX and LAN7801. The KSZ9897R is a seven-port managed gigabit Ethernet switch. It has five 10BASE-T_e/100BASE-T_X/1000BASE-T physical layer transceivers (PHYs) and associated MAC units, and two MAC ports with individually configurable RGMII/MII/RMII interfaces. These two ports can be used for direct connection to a host Microprocessor or Microcontroller, another Ethernet switch or an Ethernet PHY.

KSZ9031 is a single chip 10/100/1000 Mbps IEEE 802.3 compliant Ethernet PHY. This demonstration board features the RGMII variant, KSZ9031RNX, of the KSZ9031 family. This feature-rich device offers diagnostic features, such as, LinkMD®, Parametric NAND tree and loopback functions to facilitate system bring-up and debugging in product testing and deployment. The on-chip termination resistors for the four differential pairs reduce the total board cost.

LAN7801 is a USB 3.1 to 10/100/1000 Gigabit Ethernet bridge with integrated OTP and EEPROM controller. The internal USB controller and USB PHY are compliant with the USB 3.1 Gen 1 SuperSpeed standard that implements Control, Interrupt, Bulk-in, and Bulk-out USB Endpoints. The Ethernet controller is compliant with the IEEE 802.3, IEEE 802.3u, IEEE 802.3ab, and 802.3az (Energy Efficient Ethernet) standards. The device provides multiple power management features, including Energy Efficient Ethernet (IEEE 802.3az), support for Microsoft's Always On Always Connected (AOAC), and "Magic Packet", "Wake On LAN", and "Link Status Change" wake events.

An external clock, DSC400, is used on this board to provide very low jitter clock pulses to the KSZ9897, LAN7801 and KSZ9031 Gigabit Ethernet controllers. The DSC400 is a four output crystal-less™ clock generator. It utilizes MEMS technology to provide excellent jitter and stability while providing excellent shock and vibration immunity. The device outputs wide frequency range of 2.3 MHz to 460 MHz with high noise rejection of -50 dBc. The DSC400 provides two independent select lines for choosing between two sets of pre-configured frequencies per bank. It also has two Output Enable pins to allow for enabling and disabling outputs.

On this board, the KSZ9897R Ethernet switch's five ports, 1 through 5, are connected directly to RJ45 Ethernet jacks with integrated magnetics which are available to use with any Ethernet devices. The rest of the two MAC ports are configured as RGMII interfaces. Port 6 is connected to a KSZ9031 Gigabit Ethernet PHY and an RJ45 Ethernet jack with integrated magnetics and port 7 is connected to a LAN7801 USB-to-Ethernet bridge and a USB connector.

The scope of this document is to describe the EVB-KSZ9897 evaluation board setup, which includes RGMII, SPI and I²C interface and corresponding jumper configurations. A simplified block diagram of the board is shown in [Figure 1-1](#).

FIGURE 1-1: KSZ9897 BLOCK DIAGRAM

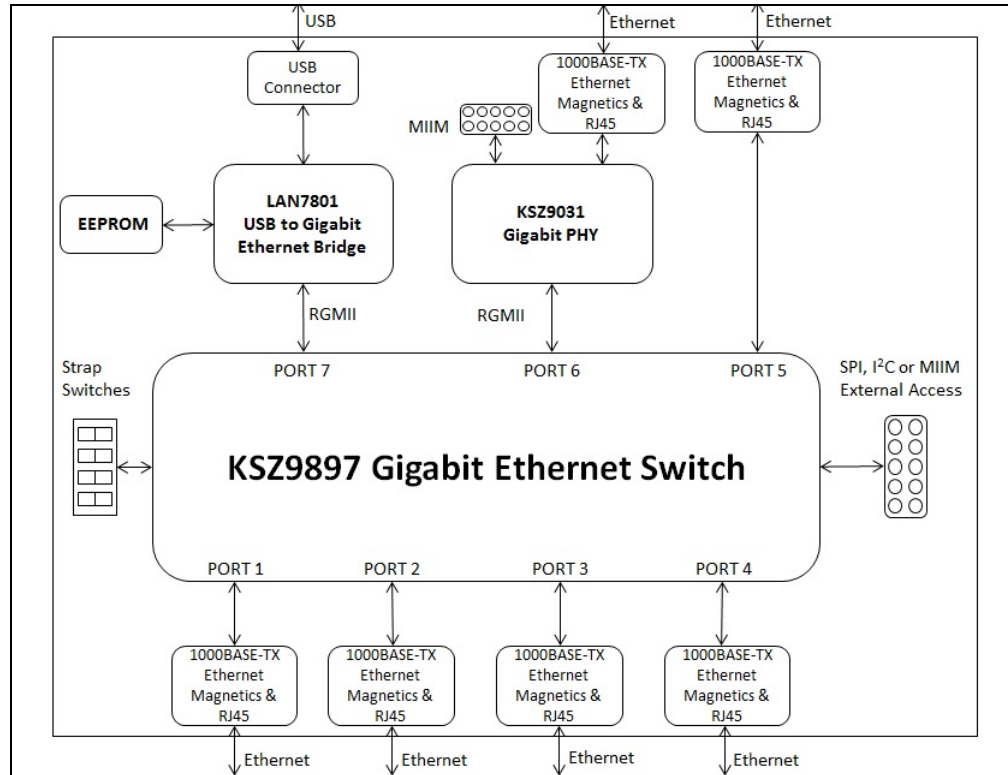

1.2 REFERENCES

Concepts and material available in the following documents will be helpful when reading this document. Visit www.microchip.com for the latest documentation.

- *KSZ9897R Data Sheet*
- *KSZ9031RNX Data Sheet*
- *LAN7801 Data Sheet*
- *EVB-KSZ9897 Schematic*
- *DSC400 Data Sheet*

1.3 TERMS AND ABBREVIATIONS

EVB - Evaluation Board

MII - Media Independent Interface

MIIM - Media Independent Interface Management, also known as MDIO/MDC

RGMII - Reduced Gigabit Media Independent Interface

I²C - Inter Integrated Circuit

SPI - Serial Protocol Interface

PHY - Physical Transceiver

Chapter 2. Board Details & Configuration

This section includes sub-sections on the following KSZ9897 details:

- [Power](#)
- [Resets](#)
- [Clock](#)
- [Configuration](#)
- [Mechanicals](#)

2.1 POWER

2.1.1 +5V Power

A 5V/2A power supply should be connected to J7 on the board. The SW2 switch must be in the ON position to power the board. The F1 fuse is provided on the board for the over voltage protection.

2.2 RESETS

2.2.1 Power-on Reset

There are three jumpers, J15, J21 and J23, available for configuring the various reset options for the chips. Unless experimentation with reset is required, it is suggested to use the default configurations highlighted in bold text in the tables below. With these default settings, pressing the SW1 reset button will reset all three devices (KSZ9897, KSZ9031 and LAN7801). By changing the jumpers, the effect of SW1 can be limited to a subset of the three devices.

2.3 CLOCK

The evaluation board utilizes an external clock, DSC400, which provides 25 MHz 25 ppm clock to the KSZ9897, LAN7801 and KSZ9031. It also provides 125 MHz to the LAN7801.

2.4 CONFIGURATION

The following sub-sections describe the various board features and configuration settings. A top view of the KSZ9897 is shown in [Figure 2-1](#).

FIGURE 2-1: KSZ9897 TOP VIEW WITH CALLOUTS

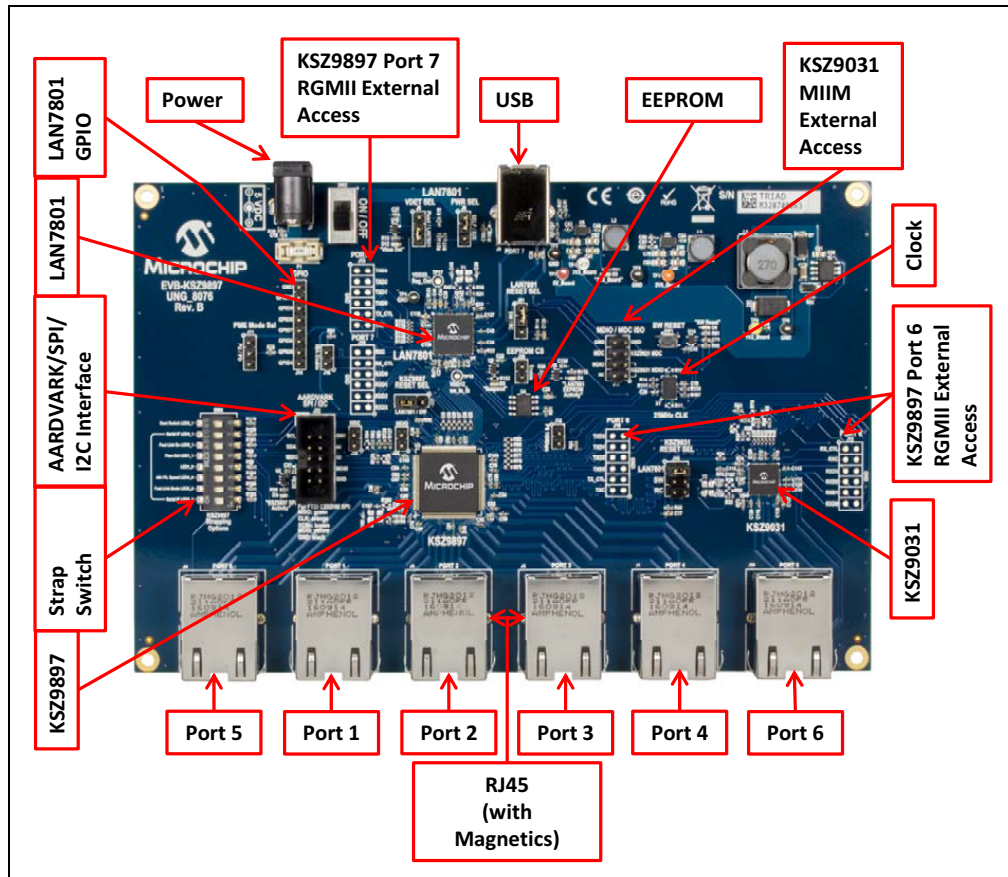

Board Details & Configuration

2.4.1 Switch Settings

SW4 is an eight-position switch which controls many of the KSZ9897 configuration strap options. The KSZ9897 samples these signals at the rising edge of RESET_N to determine some internal settings. Following reset, the configuration of these switches is irrelevant. For initial bring-up, leave most switches in the OFF/OPEN position.

2.4.1.1 KSZ9897 MANAGEMENT INTERFACE MODE

The management interface can be configured to be SPI, I²C or MIIM (a.k.a. MDC/MDIO). This is controlled by switches 1 and 7 of SW4.

[Table 2-1](#) details the switch configuration for the management interface mode.

TABLE 2-1: MANAGEMENT INTERFACE MODE

SW4.7 (LED4_1)	SW4.1(LED3_1)	Mode
On	On	MDIO
On	Off	I ² C
Off	Don't Care	SPI

2.4.1.2 OTHER SWITCH SETTINGS

Please refer the device data sheet for the detailed configuration strap settings.

2.4.2 Jumper Settings

[Table 2-2](#), [Table 2-3](#) and [Table 2-4](#) describe the jumper settings. The preferred configuration is shown in bold text.

TABLE 2-2: TWO-PIN JUMPERS

Jumper	Label	Description	Open	Closed
J16	P6 100 Mbps	KSZ9897 Port 6 RGMII speed configuration strap setting. The setting of this jumper takes effect only after reset. This setting must match the actual link speed of port 6. The KSZ9897 port 6 speed can also be set via the SPI or I ² C interface by writing to registers 0x6300 (bit 4) and 0x6301 (bit 6). See the data sheet for details. This method is required when the port 6 link speed is 10 Mbps.	1000 Mbps	100 Mbps
J18	IBA Enable	Enable KSZ9897 In-Band-Management (IBA) (Configuration strap)	Disabled (Default)	Enabled
J28	EEPROM CS	Enable external EEPROM for LAN7801	Disabled	Enabled

TABLE 2-3: THREE-PIN JUMPERS

Jumper	Label	Description	Jumper 1-2	Jumper 2-3
J6	PWR SEL	Board power source: 5V barrel connector or USB	Power from barrel jack	USB powered (not recommended)
J8	VDET SEL	LAN7801 USB Vbus detect	Board +3.3V	Vbus from USB connector (Default)
J11	PME Mode SEL	LAN7801 PME Mode input pin	High (Default)	Low

TABLE 2-3: THREE-PIN JUMPERS (CONTINUED)

Jumper	Label	Description	Jumper 1-2	Jumper 2-3
J21	LAN7801 RESET SEL	LAN7801 Reset input source	Master SW1 & RC Circuit (Default)	Alternate RC circuit
J23	KSZ9897 RESET SEL	KSZ9031 Reset input source	Master SW1 & RC circuit	LAN7801 Reset output (Default)
J24	KSZ9897 MDIO enable	Install these jumpers to allow the KSZ9897 MIIM interface (together with the KSZ9031 MIIM interface) to be accessible from the LAN7801 or from J17. If the KSZ9897 management port is configured for SPI or I ² C, do not install these jumpers.		
J25	KSZ9897 MDC enable			

TABLE 2-4: MULTI-PIN HEADERS

Jumper	Label	Description	Configuration
J15	KSZ9031 RESET SEL	KSZ9031 Reset input source 3x2 header	Install a jumper on one of the three pairs only: 1-2: LAN7801 Reset output (Default) 3-4: Master SW1 & RC circuit 5-6: Alternate RC circuit
J17	MDIO/MDC ISO	KSZ9031 MIIM (MDC/MDIO) external access and jumpers 4hx2 header	Install jumpers 3-4 and 5-6 to access the KSZ9031 MIIM bus from the LAN7801. (Not cur- rently available) For external access to KSZ9031 MIIM bus, install only jumper 2-4, and use pins 1,3,5 and 7 for external connection.
J14	GPIO	LAN7801 GPIO pins 8x1 header	Provides access to the GPIO pins of the LAN7801. No jump- ers.
J22	AARDVARK	KSZ9897 SPI/I ² C header for external access 5x2 header	Supports Aardvark (TTP100005 - Total Phase Aardvark I ² C/SPI Host Adapter) and Cheetah (TTP100004 - Total Phase Cheetah SPI Host Adapter) from Totalphase.

2.4.3 SPI, I²C and MIIM Management

External access to the KSZ9031 MIIM bus is available via header J17 as outlined in the table above. External access to the KSZ9897 (either SPI, I²C or MIIM) is available via header J22 as outlined in [Table 2-4](#). If both connections are needed simultaneously, it will be necessary to remove resistor R95. Please visit [Table 2-5](#) and [Table 2-6](#) for I²C and SPI connections.

TABLE 2-5: I²C

I ² C Signal	Connector Pin
SDA	J22.3 and/or J22.8
SCL	J22.7 (R126 not currently installed)
GND	J22.2 and/or J22.10

Board Details & Configuration

TABLE 2-6: SPI

SPI Signal	Connector Pin
MISO	J22.5
MOSI	J22.8
SCK	J22.7
SS	J22.9
GND	J22.2 and/or J22.10

FIGURE 2-2: SPI/AARDVARK HEADER

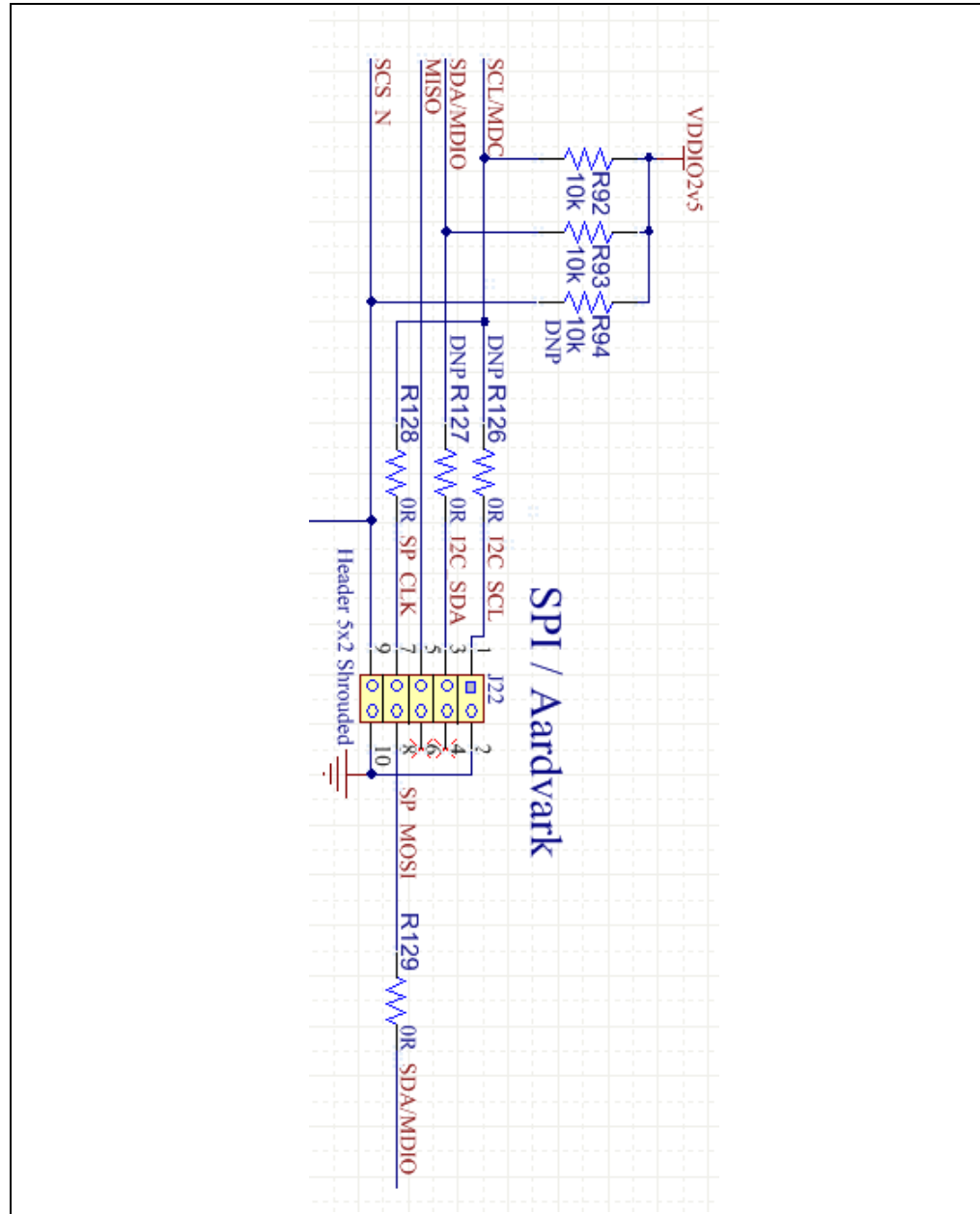

Note: Communication formats and register details are provided in the device data sheets. Note that SPI or I²C provide access to all KSZ9897 registers, but MIIM does not. It only provides access to the PHY registers of the switch.

2.5 USING THE EVB-KSZ9897

The EVB-KSZ9897 board can be used to connect up to 7 Ethernet devices using 6 Ethernet ports and 1 USB port.

For example, connect a PC (PC1) on port 1 and another PC (PC2) to port 2. Configure both PCs for STATIC IP address using the Ethernet interface's properties windows. Then, run a simple PING command to test communication between the two PCs. Lastly, connect PC2 to the USB port, port 7, on the board.

A user can access the KSZ9897 switch's internal registers by connecting Aardvark I²C/SPI host adapter to jumper 22. The adapter is available to purchase from MicrochipDirect.com web site (part number TTP100005).

2.6 MECHANICALS

FIGURE 2-3: KSZ9897 MECHANICAL DIMENSIONS

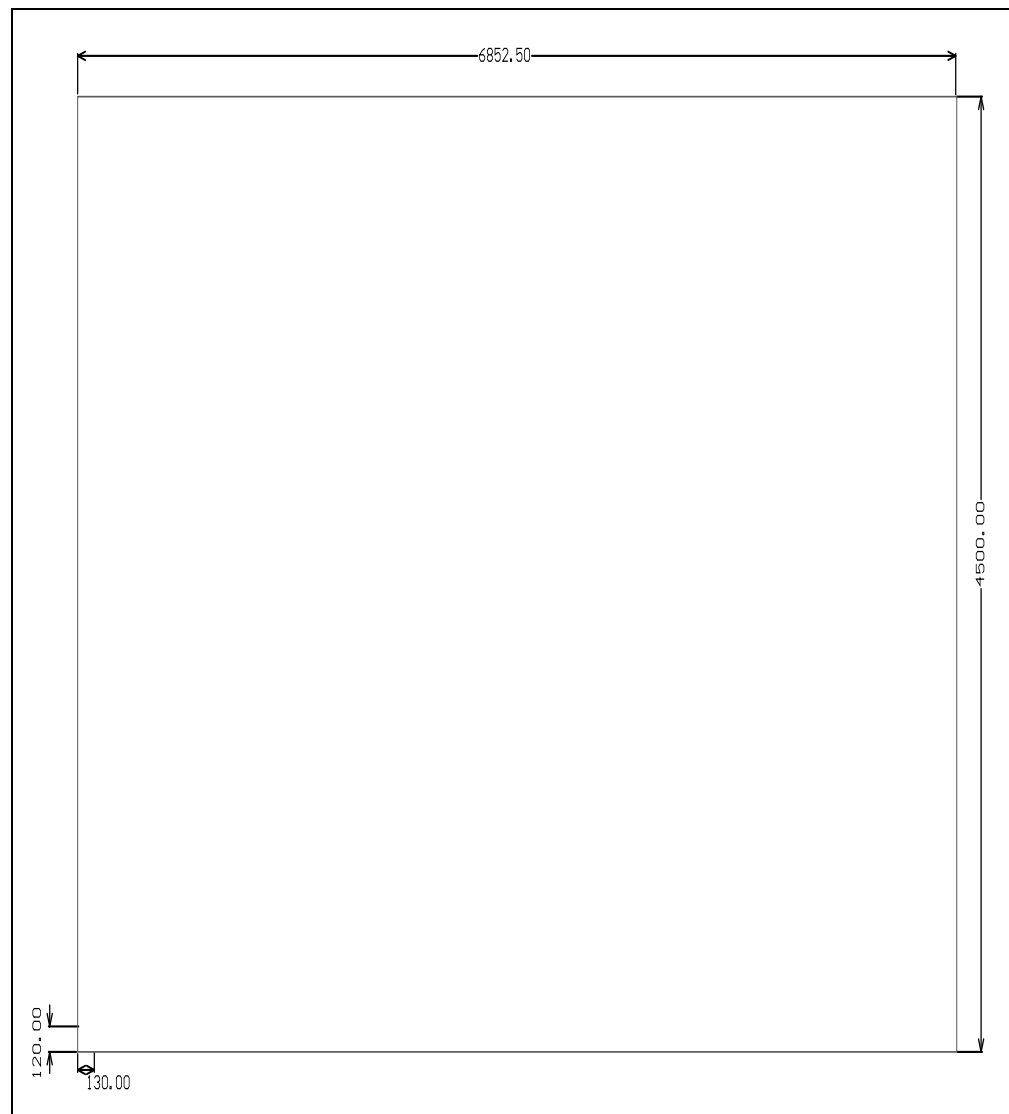

Appendix A. EVB-KSZ9897 Evaluation Board

A.1 INTRODUCTION

This appendix shows the EVB-KSZ9897 Evaluation Board.

FIGURE A-1: EVB-KSZ9897 EVALUATION BOARD

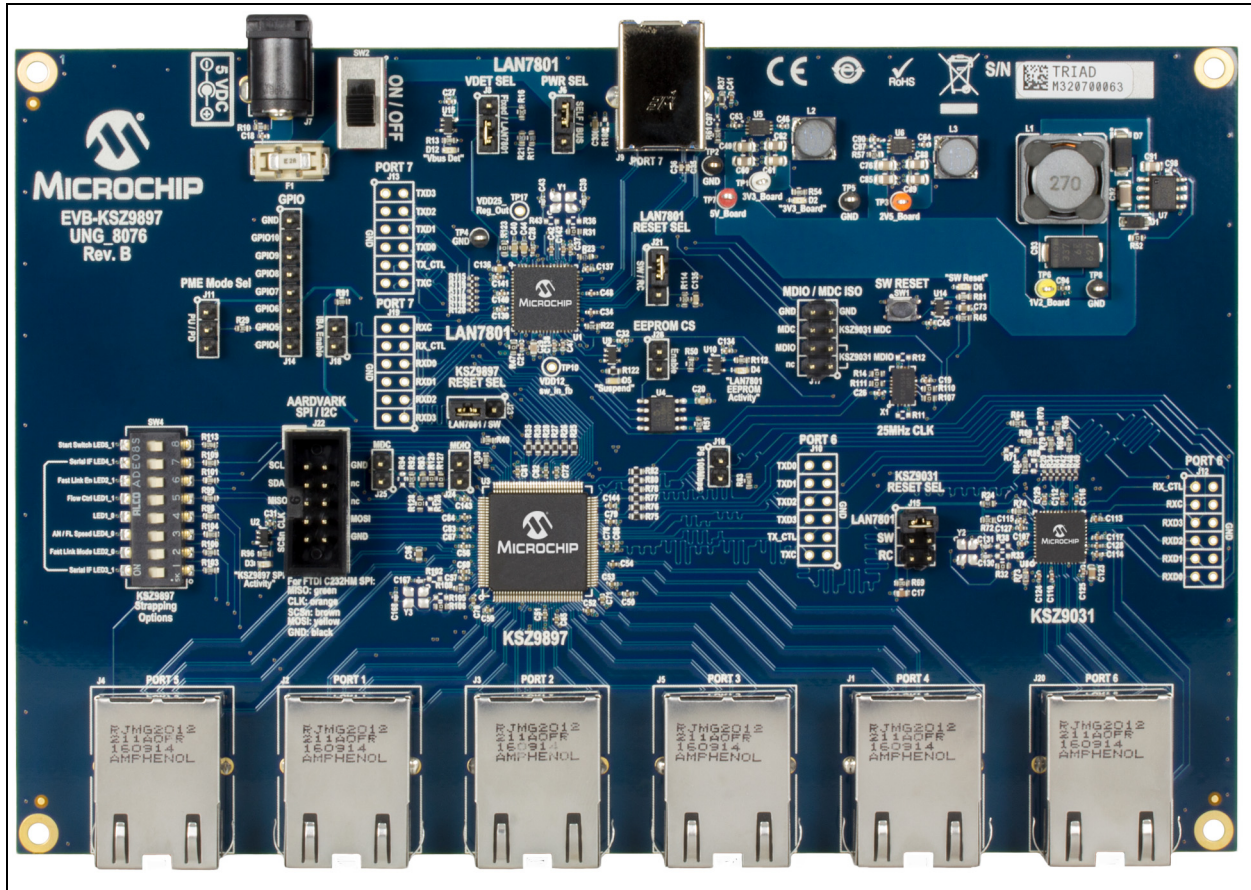

NOTES:



Appendix B. EVB-KSZ9897 Evaluation Board Schematics

B.1 INTRODUCTION

This appendix shows the EVB-KSZ9897 Evaluation Board Schematics.

FIGURE B-1: KSZ9897 FUNCTIONAL

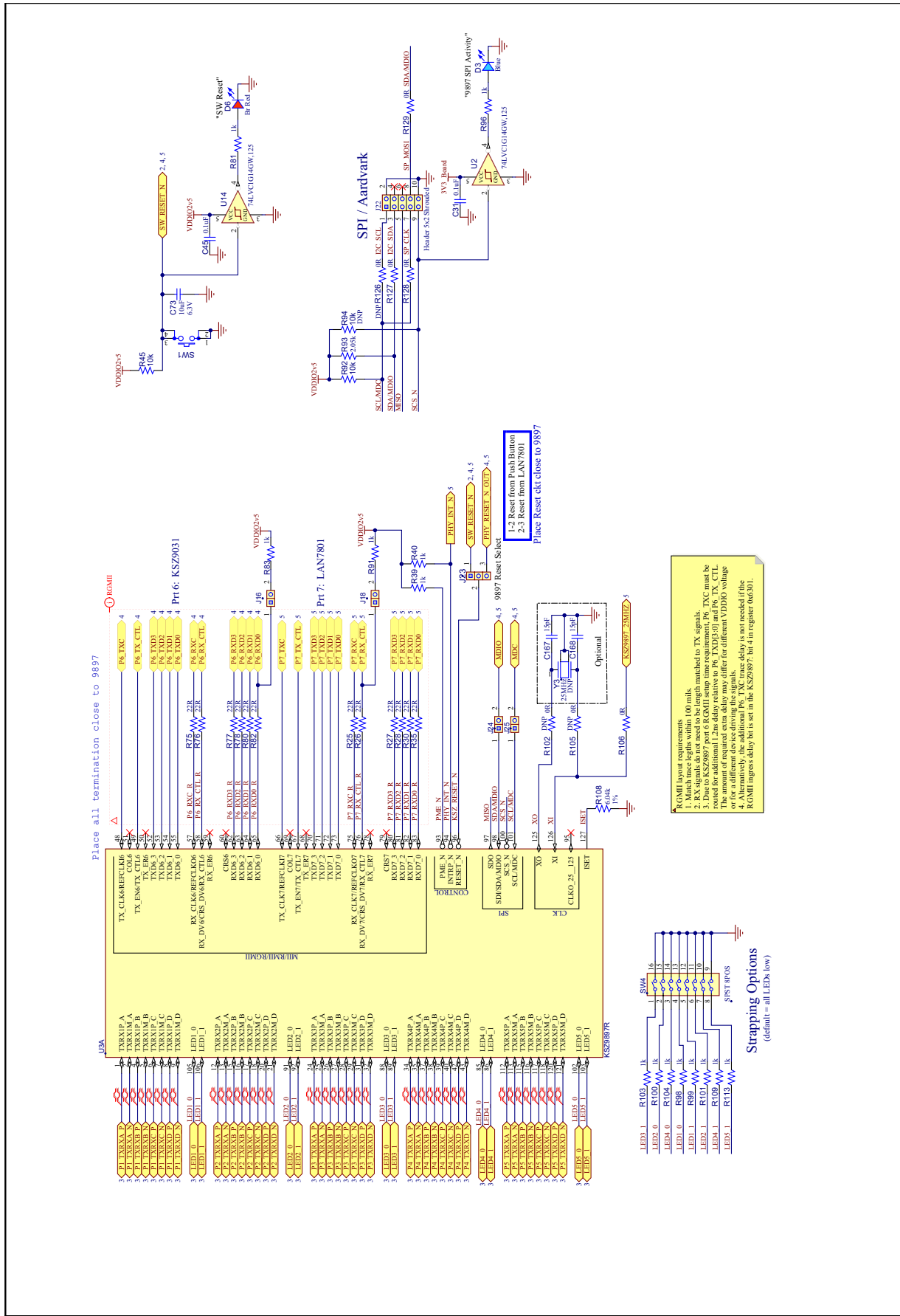

RGMI layout requirements:

1. TX signals do not need to be length matched to TX signals.
2. RX signals do not need to be length matched to TX signals.
3. Due to KSZ9897 part 6 RGMI setup time requirement, P6_TX must be routed for additional 1.2ns delay relative to P6_TXD[3:0] and P6_TX_CTL.
4. Alternatively, the additional P6_TX trace delay is not needed if the RGMI ingress delay bit is set in the KSZ9897 bit 4 in register 0x501.

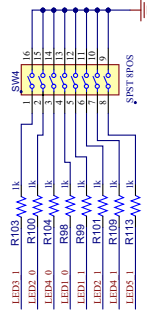

FIGURE B-2: RJ45 MAGJACK CONNECTORS

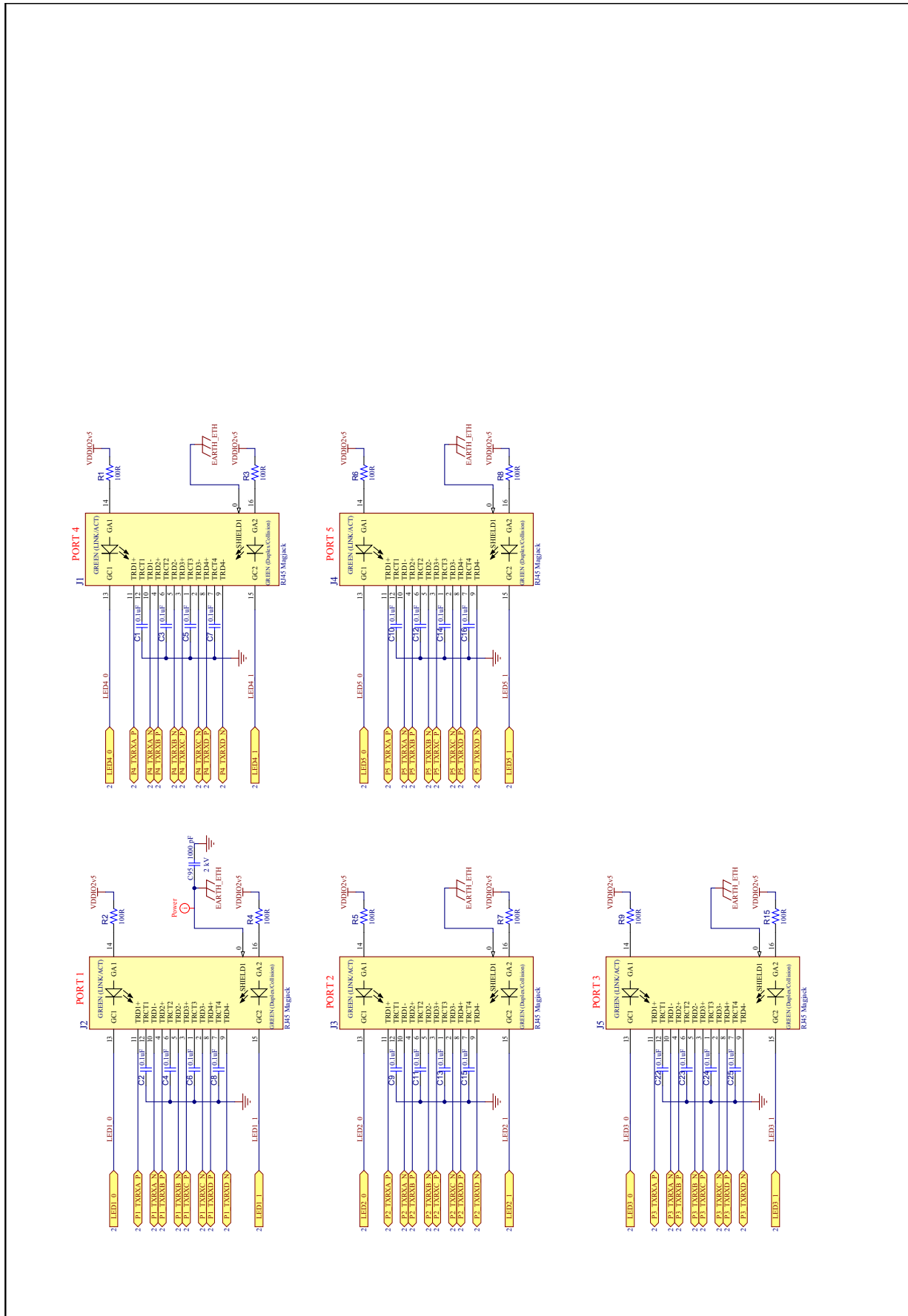

FIGURE B-3: KSZ9031 FUNCTIONAL

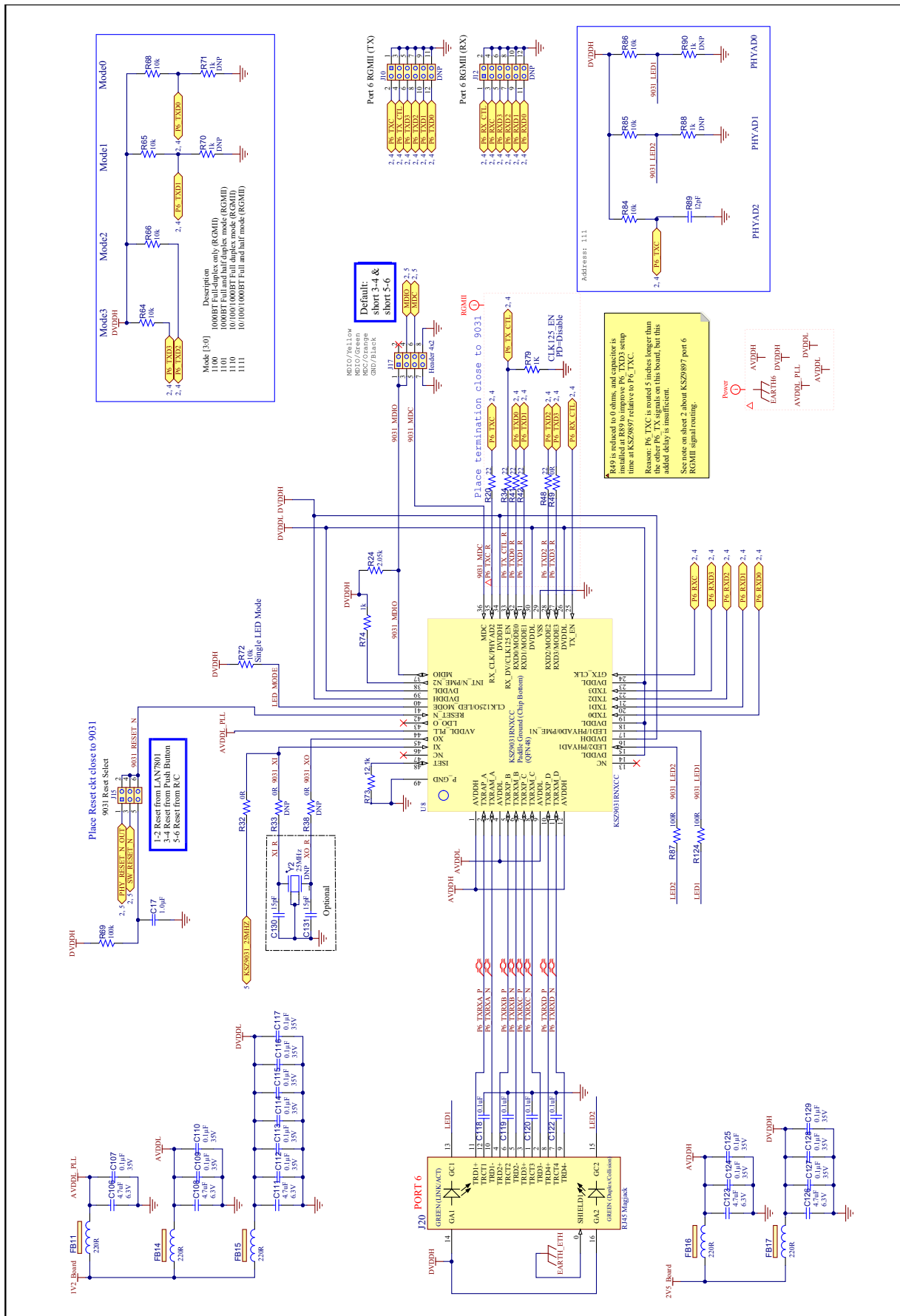

FIGURE B-4: LAN7801 64QFN FUNCTIONAL

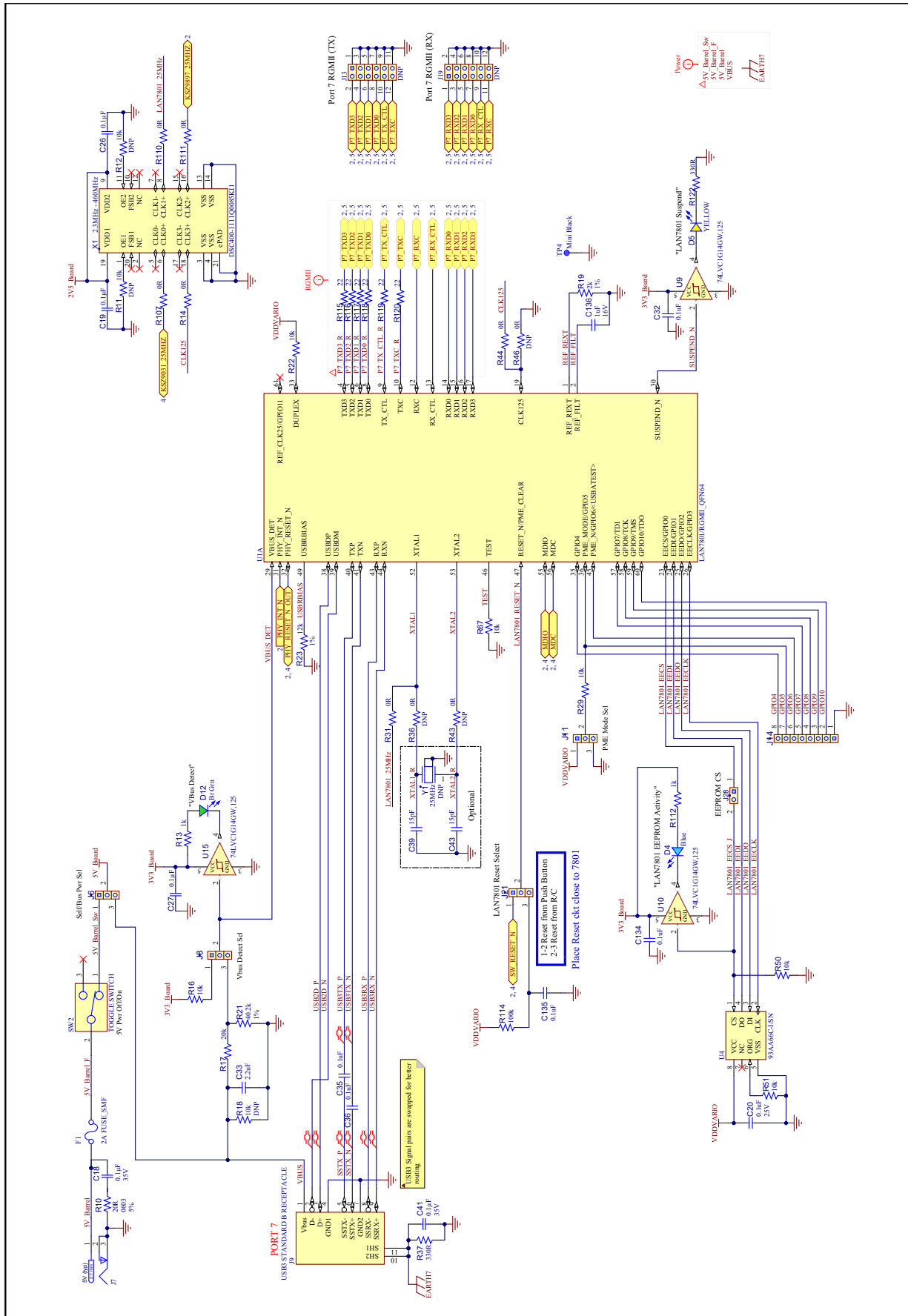
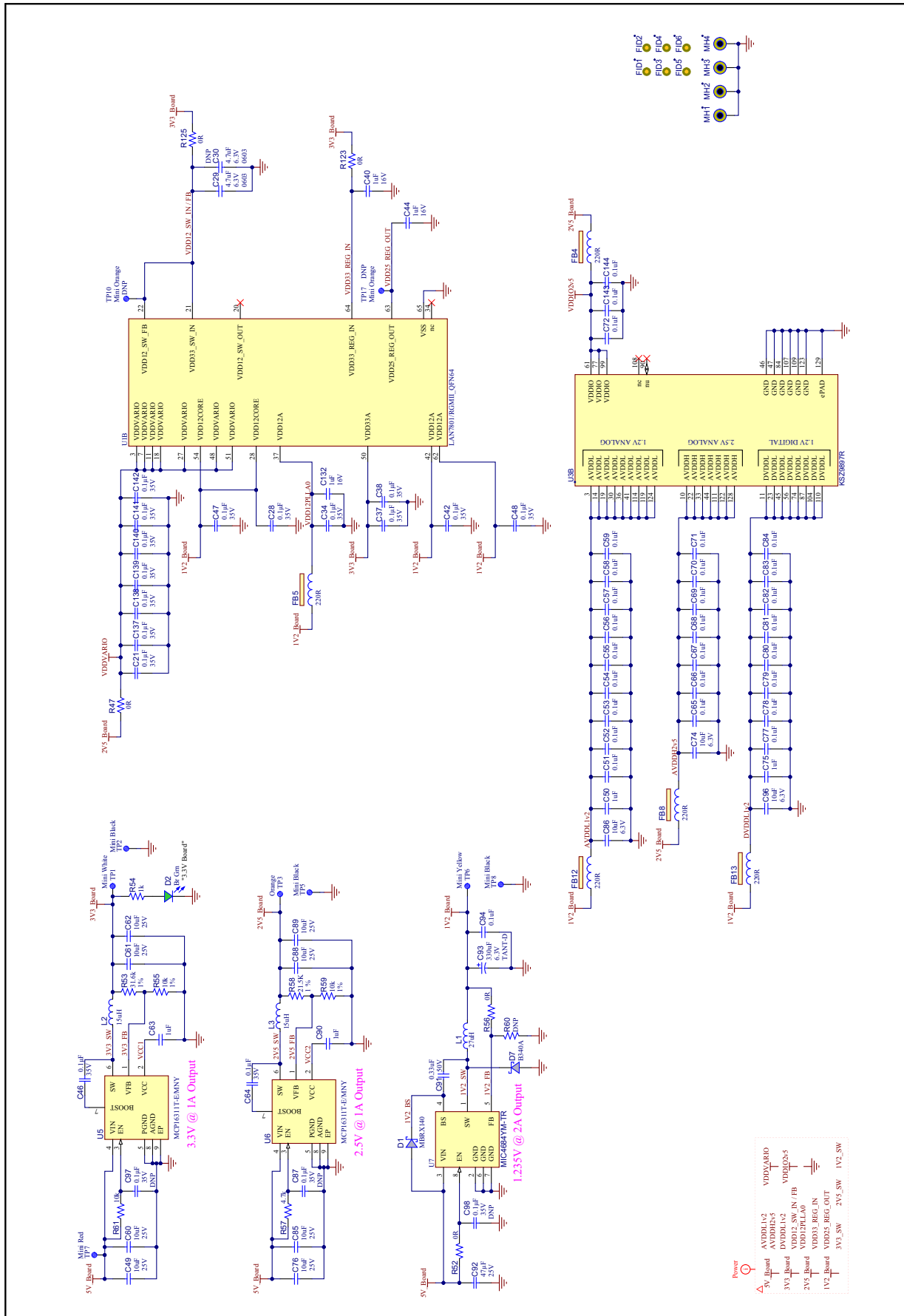

FIGURE B-5: LAN7801 / KSZ9897 POWER & REGULATORS





Appendix C. Bill of Materials (BOM)

C.1 INTRODUCTION

This appendix includes the EVB-KSZ9897 Evaluation Board Bill of Materials (BOM).

TABLE C-1: EVB-KSZ9897 EVALUATION BOARD BILL OF MATERIALS

Item	Qty	Reference	Description	Populated	Manufacturer	Manufacturer Part Number
1	56	C1, C2, C3, C4, C5, C6, C7, C8, C9, C10, C11, C12, C13, C14, C15, C16, C22, C23, C24, C25, C31, C32, C45, C51, C52, C53, C54, C55, C56, C57, C58, C59, C65, C66, C67, C68, C69, C70, C71, C72, C77, C78, C79, C80, C81, C82, C83, C84, C94, C118, C119, C120, C122, C134, C143, C144	CAP CER 0.1uF 50V 10% X7R SMD 0402	YES	TDK Corporation	C1005X7R1H104K050BB
2	1	C17	CAP CER 1uF 50V 10% X7R 0603	YES	Taiyo Yuden	UMK107AB7105KA-T
3	35	C18, C19, C21, C26, C27, C28, C34, C37, C38, C41, C42, C46, C47, C48, C64, C107, C109, C110, C112, C113, C114, C115, C116, C117, C124, C125, C127, C128, C129, C137, C138, C139, C140, C141, C142	CAP CER 0.1uF 35V X5R 0402	YES	TDK Corporation	C1005X5R1V104M050BB
4	2	C20, C135	CAP CER 0.1uF 25V 10% X7R SMD 0603	YES	Murata	GRM188R71E104KA01D
5	6	C29, C106, C108, C111, C123, C126	CAP CER 4.7uF 6.3V 20% X5R SMD 0603	YES	Panasonic	ECJ-1VB0J475M
6	1	C33	CAP CER 2.2uF 6.3V 10% X7R SMD 0603	YES	TDK	C1608X7R0J225K
7	2	C35, C36	CAP CER 0.1uF 10V 10% X5R SMD 0402	YES	KEMET	C0402C104K8PACTU
8	6	C39, C43, C130, C131, C167, C168	CAP CER 15pF 50V 5% NP0 SMD 0402	YES	Murata	GRM1555C1H150JA01D
9	4	C40, C44, C132, C136	CAP CER 1uF 16V 10% X5R SMD 0603	YES	AVX	0603YD105KAT2A
10	8	C49, C60, C61, C62, C76, C85, C88, C89	CAP CER 10uF 25V 10% X5R SMD 0805	YES	Murata	GRM21BR61E106KA73L
11	2	C50, C75	CAP CER 1uF 16V 10% X5R SMD 0402	YES	TDK Corporation	C1005X5R1C105K
12	2	C63, C90	CAP CER 1uF 35V 10% X5R SMD 0402	YES	Murata Electronics North America	GRM155R6YA105KE11D
13	4	C73, C74, C86, C96	CAP CER 10uF 6.3V 20% X5R SMD 0603	YES	AVX	06036D106MAT2A
14	1	C91	CAP CER 0.33uF 50V 10% X7R SMD 0805	YES	TDK Corporation	C2012X7R1H334K125AA
15	1	C92	CAP CER 47uF 25V X5R 1206	YES	TDK Corporation	C3216X5R1E476M160AC
16	1	C93	CAP TANT 330uF 6.3V 20% 45mOhm SMD D	YES	KEMET	T520D337M006ATE045
17	1	C95	CAP CER 1000PF 2KV 1808	YES	Murata	GR442QR73D102KW01L

Bill of Materials (BOM)

TABLE C-1: EVB-KSZ9897 EVALUATION BOARD BILL OF MATERIALS (CONTINUED)

Item	Qty	Reference	Description	Populated	Manufacturer	Manufacturer Part Number
18	1	R89	CAP CER 12pF 50V 5% NP0 SMD 0603	YES	Panasonic	ECJ-1VC1H120J
19	1	D1	DIO SCTKY MBRX140-TP 550mV 1A 40V SMD SOD-123	YES	Micro Commercial Co	MBRX140-TP
20	2	D2, D12	LED, Bright Green, .0603	YES	Lite-On	LTST-C191KGKT
21	2	D3, D4	LED, Blue, .0603	YES	Kingbright	APT1608VBC/D
22	1	D5	DIO LED YELLOW 2.1V 20mA 14mcd Diffuse SMD 0603	YES	Lumex	sml-lx0603yw
23	1	D6	LED, Bright Red, .0603	YES	Lite-On	LTST-C191KRKT
24	1	D7	DIO SCTKY B340A 500mV 3A 40V DO-214AC_SMA	YES	Diodes Incorporated	B340A-13-F
25	1	F1	Surface Mount Fuses Fuseblock w/ fuse 2A OMNI BLOK 154	YES	Littelfuse	0154002.DR
26	10	FB4, FB5, FB8, FB11, FB12, FB13, FB14, FB15, FB16, FB17	FERRITE 2A 220R SMD 0805	YES	Murata Electronics North America	BLM21PG221SN1D
27	6	J1, J2, J3, J4, J5, J20	CON MODULAR RJ45 MAGJACK TH R/A	YES	Amphenol Commercial Products	RJMG2012211A0FR
28	3	J6, J8, J11	HDR 3POS .100" SGL GOLD	YES	Samtec Inc.	TSW-103-07-G-S
29	1	J7	CONN PWR JACK 2.5X5.5MM HIGH CUR	YES	CUI Inc.	PJ-002AH
30	1	J9	CONN RCPT USB TYPE B 3.0 R/A	YES	Würth Electronics Inc	6.92221E+11
31	1	J14	CON HDR-2.54 MALE 1x8 GOLD 5.84MH TH VERT	YES	Samtec	TSW-108-07-G-S
32	1	J15	CONN HEADER 6POS .100" DUAL GOLD	YES	Samtec	TSW-103-07-G-D
33	4	J16, J18, J24, J25	CON HDR-2.54 MALE 1x2 GOLD 5.84MH TH VERT	YES	Samtec	TSW-102-07-G-S
34	1	J17	CON HDR-2.54 Male 2x3 Gold 5.84MH TH VERT	YES	Samtec	TSW-104-07-G-D
35	2	J21, J23	CON HDR-2.54 MALE 1x3 GOLD 5.84MH TH VERT	YES	Samtec	TSW-103-07-G-S
36	1	J28	HDR 2POS .100" SGL GOLD	YES	Samtec Inc.	TSW-102-07-G-S
37	1	L1	IND 27uH 20 % 2.35A SMD	YES	Bourns	SRR1240-270M
38	2	L2, L3	INDUCTOR 15uH 1.16A 20% SMD MSS6132	YES	Coilcraft	MSS6132-153ML
39	12	R1, R2, R3, R4, R5, R6, R7, R8, R9, R15, R87, R124	RES TKF 100R 5% 1/10W SMD 0603	YES	Panasonic	ERJ-3GEYJ101V
40	1	R10	RES TKF 20R 5% 1/10W SMD 0603	YES	NIC Components	NRC06J200TRF
41	2	R13, R54	RES 1k 5% 1/10W SMD 0603	YES	Panasonic Electronic Components	ERJ-3GEYJ102V
42	16	R14, R31, R32, R44, R47, R52, R56, R106, R107, R110, R111, R123, R125, R127, R128, R129	RES TKF 0R 1/10W SMD 0603	YES	Panasonic	ERJ-3GEY0R00V
43	1	R49	RES TKF 0R SMD 0402	YES	Panasonic	ERJ-2GE0R00X
44	15	R16, R22, R29, R50, R51, R61, R64, R65, R66, R67, R68, R72, R84, R85, R86	RES TKF 10k 5% 1/10W SMD 0603	YES	Panasonic	ERJ-3GEYJ103V
45	1	R17	RES TKF 20k 5% 1/10W SMD 0603	YES	Panasonic	ERJ-3GSYJ203

TABLE C-1: EVB-KSZ9897 EVALUATION BOARD BILL OF MATERIALS (CONTINUED)

Item	Qty	Reference	Description	Populated	Manufacturer	Manufacturer Part Number
46	1	R19	RES TKF 2k 1% 1/10W SMD 0603	YES	Panasonic	ERJ-3EKF2001V
47	11	R20, R34, R41, R42, R48, R115, R116, R117, R118, R119, R120	RES 22ohm 5% 1/10W SMD 0402	YES	Panasonic	ERJ-2GEJ220X
48	1	R21	RES TKF 40.2k 1% 1/16W SMD 0603	YES	Panasonic Electronic Components	ERJ-3EKF4022V
49	1	R23	RES TKF 12k 1% 1/10W SMD 0603	YES	Yageo	RC0603FR-0712KL
50	2	R24, R93	RES TKF 2.05k 1% 1/10W SMD 0603	YES	Yageo	RC0603FR-072K05L
51	12	R25, R26, R27, R28, R30, R35, R75, R76, R77, R78, R80, R82	RES TKF 22R 1% 1/10W SMD 0603	YES	Yageo	RC0603FR-0722RL
52	1	R37	RES TKF 330R 5% 1/10W SMD 0603	YES	Panasonic Electronic Components	ERJ-3GEYJ331V
53	17	R39, R40, R74, R79, R81, R83, R91, R96, R98, R99, R100, R101, R103, R104, R109, R112, R113	RES TKF 1k 5% 1/10W SMD 0603	YES	Panasonic	ERJ-3GEYJ102V
54	2	R45, R92	RES TKF 10k 5% 1/10W SMD 0603	YES	Panasonic	ERJ-3GEYJ103V
55	1	R53	RES TKF 31.6k 1% 1/10W SMD 0603	YES	Panasonic Electronic Components	ERJ-3EKF3162V
56	2	R55, R59	RES TKF 10k 1% 1/10W SMD 0603	YES	NIC Components	NRC06F1002TRF
57	1	R57	RES TKF 4.7k 5% 1/10W SMD 0603	YES	Panasonic	ERJ-3GEYJ472V
58	1	R58	RES TKF 21.5k 1% 1/10W SMD 0603	YES	Panasonic	ERJ-3EKF2152V
59	2	R69, R114	RES TKF 100k 5% 1/10W SMD 0603	YES	Panasonic	ERJ-3GEYJ104V
60	1	R73	RES 12.1k 1% 1/10W 0603	YES	Panasonic Electronic Components	ERJ-3EKF1212V
61	1	R108	RES TKF 6.04k 1% 1/10W SMD 0603	YES	Yageo	9T06031A6041FBHFT
62	1	R122	RES TKF 330R 5% 1/10W SMD 0603	YES	Panasonic	ERJ-3GEYJ331V
63	1	SW1	Tactile Switch SPST-NO Top Actuated Surface Mount	YES	C&K	PTS810 SJM 250 SMTR LFS
64	1	SW2	Slide Switch SPDT Through Hole	YES	C&K	1101M2S3CQE2
65	1	SW4	SWITCH SLIDE SPST 24V 100mA 1825058-9EXT ACT 8POS 24V	YES	TE Connectivity Alcoswitch Switches	1-1825058-9
66	1	TP1	TEST POINT PC MINI .040"D WHITE	YES	Keystone Electronics	5002
67	4	TP2, TP4, TP5, TP8	TEST POINT PC MINI .040"D BLACK	YES	Keystone Electronics	5001
68	1	TP3	TEST POINT PC MINI .040"D ORANGE	YES	Keystone Electronics	5003
69	1	TP6	TEST POINT PC MINI .040"D YELLOW	YES	Keystone Electronics	5004
70	1	TP7	TEST POINT PC MINI .040"D RED	YES	Keystone Electronics	5000
71	5	U2, U9, U10, U14, U15	74LVC1G14GW,125 SCHMITT-TRG INVERTER	YES	NXP	74LVC1G14GW,125
72	1	U1	Edinburgh LAN7801/RGMII pinout, QFN64	YES	Microchip	LAN7801/RGMII_QFN64

TABLE C-1: EVB-KSZ9897 EVALUATION BOARD BILL OF MATERIALS (CONTINUED)

Item	Qty	Reference	Description	Populated	Manufacturer	Manufacturer Part Number
73	1	U3	IC, 7-Port Gigabit Ethernet Switch with 2 RGMII / MII / RMII Interfaces, TQFP128	YES	Microchip Technology	KSZ9897RTXC
74	1	U4	IC EEPROM 4KBIT 3MHZ 8SOIC	YES	Microchip Technology	93AA66C-I/SN
75	2	U5, U6	IC REG BUCK SYNC ADJ 1A 8TDFN	YES	Microchip Technology	MCP16311T-E/MNY
76	1	U7	IC REG BUCK ADJ 2A 8SOIC	YES	Micrel Inc	MIC4884YM-TR
77	1	U8	KSZ9031RNXCC Gigabit Ethernet PHY with RGMII	YES	Microchip	KSZ9031RNXCC
78	1	J22	HDR 10POS .100" DUAL SHROUDED	YES	Adam Tech	BHR-10-VUA
79	1	X1	OSC MEMS CONFIGURABLE FOUR OUTPUT	YES	Microchip Technology	DSC400-1111Q0085K11
80	0	C30	CAP CER 4.7uF 6.3V 20% X5R SMD 0603	NO	Panasonic	ECJ-1VB0J475M
81	0	C87, C97, C98	CAP CER 0.1UF 35V X5R 0402	NO	TDK Corporation	C1005X5R1V104M050BB
82	0	J10, J12, J13, J19	CON HDR-2.54 Male 2x5 Gold 5.84MM TH VERT	NO	Samtec Inc	TSW-106-07-G-D
83	0	R11, R12, R18, R94	RES TKF 10k 5% 1/10W SMD 0603	NO	Panasonic	ERJ-3GEYJ103V
84	0	R33, R36, R38, R43, R46, R60, R102, R105, R126	RES TKF 0R 1/10W SMD 0603	NO	Panasonic	ERJ-3GEY0R00V
85	0	R70, R71, R88, R90	RES TKF 1k 5% 1/10W SMD 0603	NO	Panasonic	ERJ-3GEYJ102V
86	0	TP10, TP17	TEST POINT PC MINI .040"D ORANGE	NO	Keystone Electronics	5003
87	0	Y1, Y2, Y3	Crystal 25MHz 10pF SMD 4Pin DFN LCC	NO	Abracon	ABM8G-25.000MHZ-B4Y-T



MICROCHIP

Worldwide Sales and Service

AMERICAS

Corporate Office
2355 West Chandler Blvd.
Chandler, AZ 85224-6199
Tel: 480-792-7200
Fax: 480-792-7277
Technical Support:
<http://www.microchip.com/support>
Web Address:
www.microchip.com

Atlanta
Duluth, GA
Tel: 678-957-9614
Fax: 678-957-1455

Austin, TX
Tel: 512-257-3370

Boston
Westborough, MA
Tel: 774-760-0087
Fax: 774-760-0088

Chicago
Itasca, IL
Tel: 630-285-0071
Fax: 630-285-0075

Dallas
Addison, TX
Tel: 972-818-7423
Fax: 972-818-2924

Detroit
Novi, MI
Tel: 248-848-4000

Houston, TX
Tel: 281-894-5983

Indianapolis
Noblesville, IN
Tel: 317-773-8323
Fax: 317-773-5453
Tel: 317-536-2380

Los Angeles
Mission Viejo, CA
Tel: 949-462-9523
Fax: 949-462-9608
Tel: 951-273-7800

Raleigh, NC
Tel: 919-844-7510

New York, NY
Tel: 631-435-6000

San Jose, CA
Tel: 408-735-9110
Tel: 408-436-4270

Canada - Toronto
Tel: 905-695-1980
Fax: 905-695-2078

ASIA/PACIFIC

Asia Pacific Office
Suites 3707-14, 37th Floor
Tower 6, The Gateway
Harbour City, Kowloon

Hong Kong
Tel: 852-2943-5100
Fax: 852-2401-3431

Australia - Sydney
Tel: 61-2-9868-6733
Fax: 61-2-9868-6755

China - Beijing
Tel: 86-10-8569-7000
Fax: 86-10-8528-2104

China - Chengdu
Tel: 86-28-8665-5511
Fax: 86-28-8665-7889

China - Chongqing
Tel: 86-23-8980-9588
Fax: 86-23-8980-9500

China - Dongguan
Tel: 86-769-8702-9880

China - Guangzhou
Tel: 86-20-8755-8029

China - Hangzhou
Tel: 86-571-8792-8115
Fax: 86-571-8792-8116

China - Hong Kong SAR
Tel: 852-2943-5100
Fax: 852-2401-3431

China - Nanjing
Tel: 86-25-8473-2460
Fax: 86-25-8473-2470

China - Qingdao
Tel: 86-532-8502-7355
Fax: 86-532-8502-7205

China - Shanghai
Tel: 86-21-3326-8000
Fax: 86-21-3326-8021

China - Shenyang
Tel: 86-24-2334-2829
Fax: 86-24-2334-2393

China - Shenzhen
Tel: 86-755-8864-2200
Fax: 86-755-8203-1760

China - Wuhan
Tel: 86-27-5980-5300
Fax: 86-27-5980-5118

China - Xian
Tel: 86-29-8833-7252
Fax: 86-29-8833-7256

ASIA/PACIFIC

China - Xiamen
Tel: 86-592-2388138
Fax: 86-592-2388130

China - Zhuhai
Tel: 86-756-3210040
Fax: 86-756-3210049

India - Bangalore
Tel: 91-80-3090-4444
Fax: 91-80-3090-4123

India - New Delhi
Tel: 91-11-4160-8631
Fax: 91-11-4160-8632

India - Pune
Tel: 91-20-3019-1500

Japan - Osaka
Tel: 81-6-6152-7160
Fax: 81-6-6152-9310

Japan - Tokyo
Tel: 81-3-6880-3770
Fax: 81-3-6880-3771

Korea - Daegu
Tel: 82-53-744-4301
Fax: 82-53-744-4302

Korea - Seoul
Tel: 82-2-554-7200
Fax: 82-2-558-5932 or
82-2-558-5934

Malaysia - Kuala Lumpur
Tel: 60-3-6201-9857
Fax: 60-3-6201-9859

Malaysia - Penang
Tel: 60-4-227-8870
Fax: 60-4-227-4068

Philippines - Manila
Tel: 63-2-634-9065
Fax: 63-2-634-9069

Singapore
Tel: 65-6334-8870
Fax: 65-6334-8850

Taiwan - Hsin Chu
Tel: 886-3-5778-366
Fax: 886-3-5770-955

Taiwan - Kaohsiung
Tel: 886-7-213-7830

Taiwan - Taipei
Tel: 886-2-2508-8600
Fax: 886-2-2508-0102

Thailand - Bangkok
Tel: 66-2-694-1351
Fax: 66-2-694-1350

EUROPE

Austria - Wels
Tel: 43-7242-2244-39
Fax: 43-7242-2244-393

Denmark - Copenhagen
Tel: 45-4450-2828
Fax: 45-4485-2829

Finland - Espoo
Tel: 358-9-4520-820

France - Paris
Tel: 33-1-69-53-63-20
Fax: 33-1-69-30-90-79

France - Saint Cloud
Tel: 33-1-30-60-70-00

Germany - Garching
Tel: 49-8931-9700

Germany - Haan
Tel: 49-2129-3766400

Germany - Heilbronn
Tel: 49-7131-67-3636

Germany - Karlsruhe
Tel: 49-721-625370

Germany - Munich
Tel: 49-89-627-144-0
Fax: 49-89-627-144-44

Germany - Rosenheim
Tel: 49-8031-354-560

Israel - Ra'anana
Tel: 972-9-744-7705

Italy - Milan
Tel: 39-0331-742611
Fax: 39-0331-466781

Italy - Padova
Tel: 39-049-7625286

Netherlands - Drunen
Tel: 31-416-690399
Fax: 31-416-690340

Norway - Trondheim
Tel: 47-7289-7561

Poland - Warsaw
Tel: 48-22-3325737

Romania - Bucharest
Tel: 40-21-407-87-50

Spain - Madrid
Tel: 34-91-708-08-90
Fax: 34-91-708-08-91

Sweden - Gothenberg
Tel: 46-31-704-60-40

Sweden - Stockholm
Tel: 46-8-5090-4654

UK - Wokingham
Tel: 44-118-921-5800
Fax: 44-118-921-5820