

32-Channel Serial-to-Parallel Converter with Open-Drain Outputs

Features

- 100 mA Minimum Sink Current
- 16 MHz Shift Register Speed
- Polarity and Blanking Inputs
- CMOS-Compatible Inputs

Applications

- Inkjet and Electrostatic Print Heads
- AC-Electroluminescent Displays
- Microelectromechanical Systems (MEMS) Applications

General Description

The HV5623 is a low-voltage serial to high-voltage parallel converter with open-drain outputs. This device is designed as a driver for AC-electroluminescent displays. It can also be used in any application requiring multiple-output high-voltage current sinking capabilities, such as driving inkjet and electrostatic print heads, plasma panels, vacuum fluorescent or large matrix LCD displays.

This device consists of a 32-bit Shift register, 32 latches and control logic to perform the polarity selection and blanking of the outputs. Data is shifted through the Shift register on the high-to-low transition of the clock. The HV5623 shifts clockwise when viewed from the top of the package. A data output buffer is provided for cascading devices. This output reflects the current status of the last bit of the Shift register. Operation of the Shift register is not affected by the \overline{LE} (latch enable), \overline{BL} (blanking) and the POL (polarity) inputs. Transfer of data from the Shift register to the latch occurs when the \overline{LE} (latch enable) input is high. The data in the latch is stored when \overline{LE} is low.

Package Type

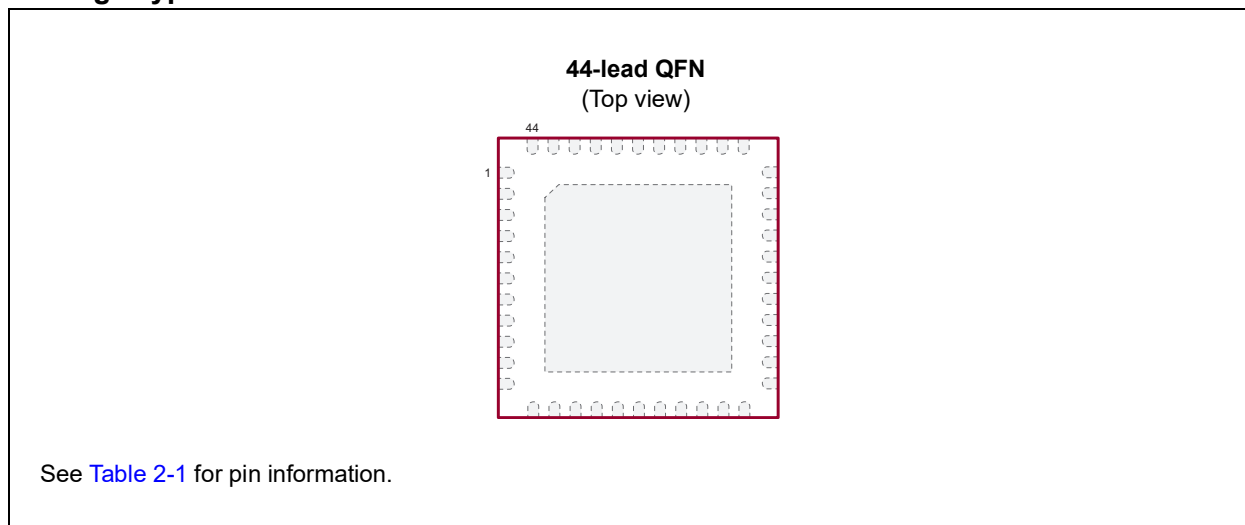

HV5623

Functional Block Diagram

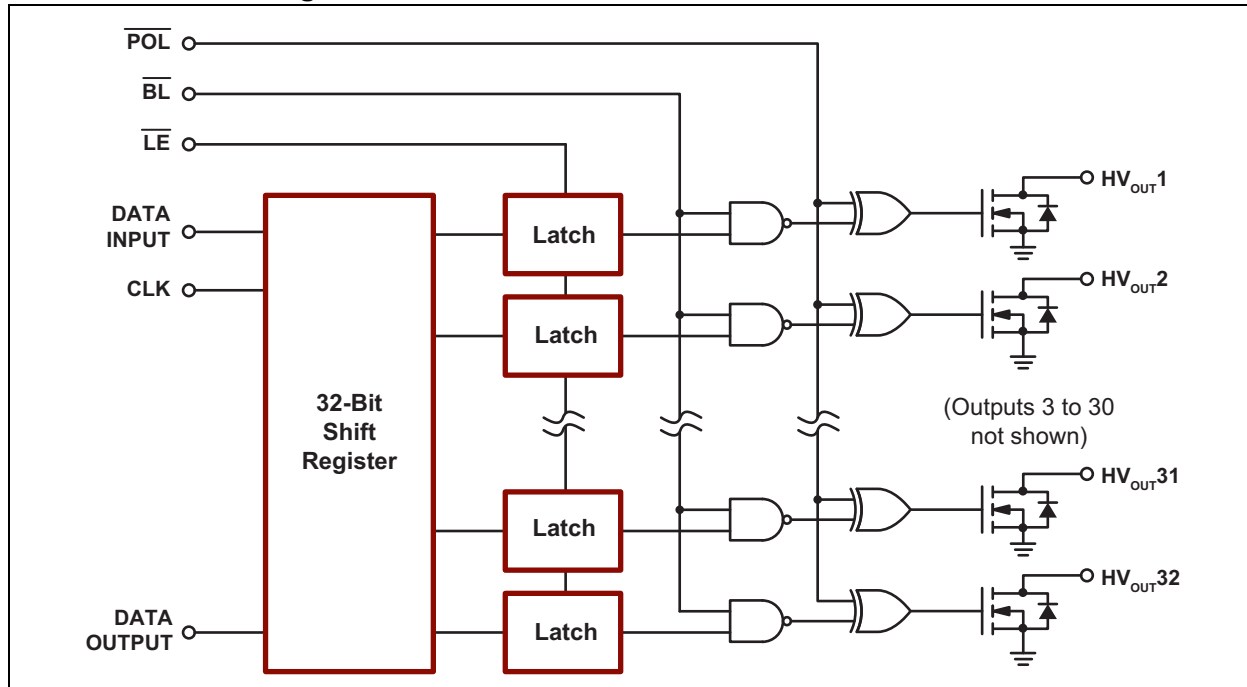

1.0 ELECTRICAL CHARACTERISTICS

Absolute Maximum Ratings†

Supply Voltage, V_{DD} (Note 1)	–0.5V to +7V
Output Voltage, HV_{OUT} (Note 1)	–0.5V to +230V
Logic Input Levels (Note 1)	–0.5V to $V_{DD} + 0.5V$
Ground Current (Note 2)	1.5A
Maximum Junction Temperature, $T_{J(MAX)}$	+125°C
Storage Temperature, T_S	–65°C to +150°C
Continuous Total Power Dissipation:	
44-lead QFN (Note 3)	3.4W

† **Notice:** Stresses above those listed under “Absolute Maximum Ratings” may cause permanent damage to the device. This is a stress rating only, and functional operation of the device at those or any other conditions above those indicated in the operational sections of this specification is not intended. Exposure to maximum rating conditions for extended periods may affect device reliability.

- Note 1:** All voltages are referenced to V_{SS} .
Note 2: Duty cycle is limited by the total power dissipated in the package.
Note 3: 1 oz 4-layer 3" x 4" PCB

RECOMMENDED OPERATING CONDITIONS

Parameter	Sym.	Min.	Typ.	Max.	Unit	Conditions
Logic Supply Voltage	V_{DD}	4.5	—	5.5	V	
High-Voltage Output	HV_{OUT}	–0.3	—	+220	V	
High-Level Input Voltage	V_{IH}	0.8 V_{DD}	—	V_{DD}	V	
Low-Level Input Voltage	V_{IL}	0	—	0.2 V_{DD}	V	
Clock Frequency	f_{CLK}	—	—	16	MHz	
Operating Ambient Temperature	T_A	–40	—	+85	°C	

DC ELECTRICAL CHARACTERISTICS

Electrical Specifications: Over recommended operating conditions unless otherwise noted.							
Parameter	Sym.	Min.	Typ.	Max.	Unit	Conditions	
V_{DD} Supply Current	I_{DD}	—	—	25	mA	$f_{CLK} = 16$ MHz, $f_{DATA} = 8$ MHz	
Quiescent V_{DD} Supply Current	I_{DDQ}	—	—	100	µA	$D_{IN} = 0V$, all input logic pins = 0V, all outputs off	
Off-State Output Current	$I_{O(OFF)}$	—	—	10	µA	All outputs high, all switches parallel	
High-Level Logic Input Current	I_{IH}	—	—	1	µA	$V_{IH} = V_{DD}$	
Low-Level Logic Input Current	I_{IL}	—	—	–1	µA	$V_{IL} = 0V$	
High-Level Output Data Out	V_{OH}	$V_{DD} - 1V$	—	—	V	$I_{DOUT} = -10$ mA	
Low-Level Output Voltage	HV_{OUT}	V_{OL}	—	—	15	V	$I_{HV_{OUT}} = +100$ mA
	Data Out		—	—	1	V	$I_{DOUT} = +10$ mA
HV_{OUT} Clamp Voltage	V_{OC}	—	—	–1.5	V	$I_{OL} = -100$ mA	

HV5623

AC ELECTRICAL CHARACTERISTICS

Electrical Specifications: $V_{DD} = 5V$, $T_J = 25^\circ C$						
Parameter	Sym.	Min.	Typ.	Max.	Unit	Conditions
Clock Frequency	f_{CLK}	—	—	16	MHz	
Clock Pulse Width, High or Low	t_{WL}, t_{WH}	31	—	—	ns	
Data Setup Time before CLK Falls	t_{SU}	25	—	—	ns	
Data Hold Time after CLK Falls	t_H	10	—	—	ns	
Turn-On Time, HV_{OUT} from Enable	t_{ON}	—	—	400	ns	$R_L = 2\text{ k}\Omega$ to V_{PP} maximum
Delay Time Clock to Data High to Low	t_{DHL}	—	—	35	ns	$C_L = 15\text{ pF}$
Delay Time Clock to Data Low to High	t_{DLH}	—	—	35	ns	$C_L = 15\text{ pF}$
Delay Time Clock to \overline{LE} Low to High	t_{DLE}	20	—	—	ns	
Width of \overline{LE} Pulse	t_{WLE}	20	—	—	ns	
\overline{LE} Setup Time before Clock Falls	t_{SLE}	20	—	—	ns	
Digital Logic Input Capacitance	C_{IN}	—	—	15	pF	

TEMPERATURE SPECIFICATIONS

Parameter	Sym.	Min.	Typ.	Max.	Unit	Conditions
TEMPERATURE RANGE						
Operating Ambient Temperature	T_A	-40	—	+85	$^\circ C$	
Maximum Junction Temperature	$T_{J(MAX)}$	—	—	+125	$^\circ C$	
Storage Temperature	T_S	-65	—	+150	$^\circ C$	
PACKAGE THERMAL RESISTANCE						
44-lead QFN	θ_{JA}	—	19	—	$^\circ C/W$	Note 1

Note 1: 1 oz 4-layer 3" x 4" PCB

Switching Waveforms

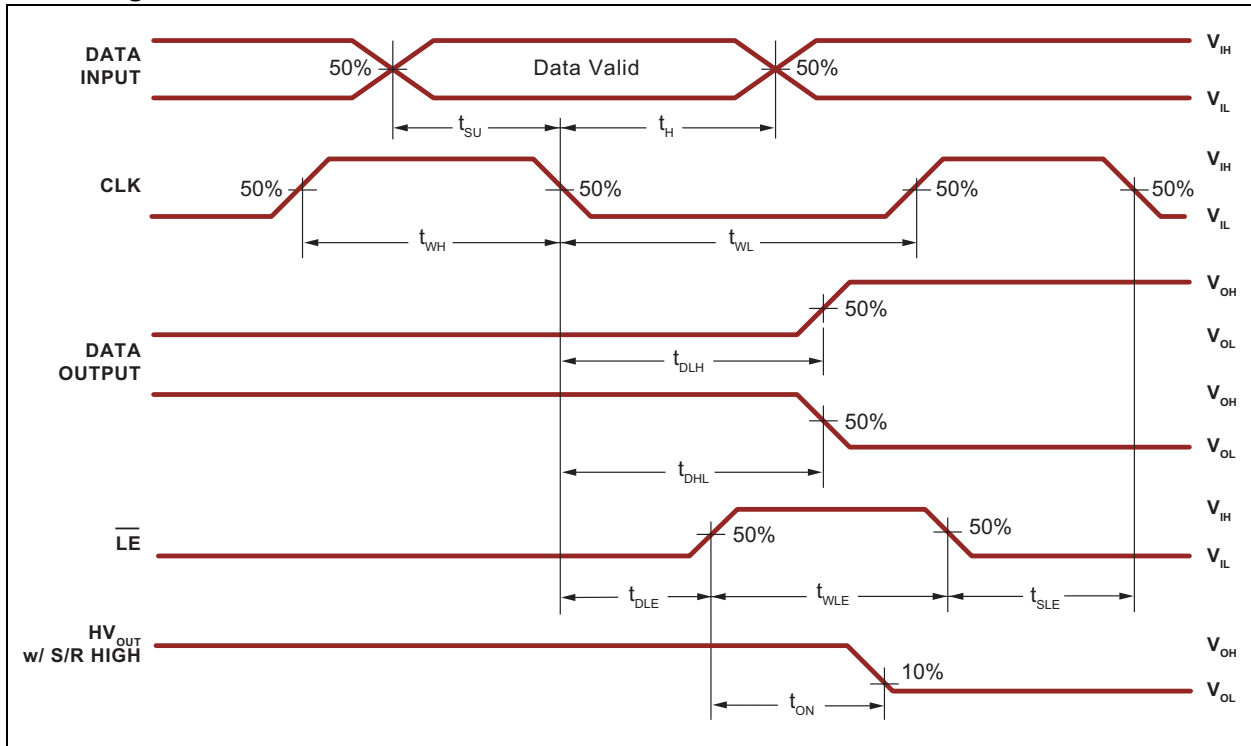

HV5623

2.0 PIN DESCRIPTION

The details on the pins of HV5623 are listed in [Table 2-1](#). Refer to [Package Type](#) for the location of pins.

TABLE 2-1: 44-LEAD QFN PIN FUNCTION TABLE

Pin Number	Pin Name	Description
1	HV _{OUT22}	High-voltage output
2	HV _{OUT21}	High-voltage output
3	HV _{OUT20}	High-voltage output
4	HV _{OUT19}	High-voltage output
5	HV _{OUT18}	High-voltage output
6	HV _{OUT17}	High-voltage output
7	HV _{OUT16}	High-voltage output
8	HV _{OUT15}	High-voltage output
9	HV _{OUT14}	High-voltage output
10	HV _{OUT13}	High-voltage output
11	HV _{OUT12}	High-voltage output
12	HV _{OUT11}	High-voltage output
13	HV _{OUT10}	High-voltage output
14	HV _{OUT9}	High-voltage output
15	HV _{OUT8}	High-voltage output
16	HV _{OUT7}	High-voltage output
17	HV _{OUT6}	High-voltage output
18	HV _{OUT5}	High-voltage output
19	HV _{OUT4}	High-voltage output
20	HV _{OUT3}	High-voltage output
21	HV _{OUT2}	High-voltage output
22	HV _{OUT1}	High-voltage output
23	DATA OUT	Data output pin
24	NC	No internal connection
25	NC	No internal connection
26	NC	No internal connection
27	$\overline{\text{POL}}$	Inverts the polarity of the HV _{OUT} pins
28	CLK	Clock pin, Shift registers shift data on falling edge of input clock.
29	VSS	Reference voltage, usually ground
30	VDD	Logic supply voltage
31	$\overline{\text{LE}}$	Latch enable pin, data is shifted from Shift register to latches on logic input high.
32	DATA IN	Data input pin
33	$\overline{\text{BL}}$	Blanking pin sets all HV _{OUT} pins on or off depending upon state of polarity. See Table 3-2 .
34	N/C	No internal connection
35	HV _{OUT32}	High-voltage output

TABLE 2-1: 44-LEAD QFN PIN FUNCTION TABLE (CONTINUED)

Pin Number	Pin Name	Description
36	HV _{OUT} 31	High-voltage output
37	HV _{OUT} 30	High-voltage output
38	HV _{OUT} 29	High-voltage output
39	HV _{OUT} 28	High-voltage output
40	HV _{OUT} 27	High-voltage output
41	HV _{OUT} 26	High-voltage output
42	HV _{OUT} 25	High-voltage output
43	HV _{OUT} 24	High-voltage output
44	HV _{OUT} 23	High-voltage output
Center Tab		Connect to VSS.

HV5623

3.0 FUNCTIONAL DESCRIPTION

Follow the steps in [Table 3-1](#) to power up and power down the HV5623.

TABLE 3-1: POWER-UP AND POWER-DOWN SEQUENCE

Power-Up		Power-Down	
Step	Description	Step	Description
1	Connect ground.	1	Remove all inputs.
2	Apply V _{DD} .	2	Remove V _{DD} .
3	Set all inputs to a known state.	3	Disconnect ground.

TABLE 3-2: FUNCTION TABLE

Function	Inputs ¹					Outputs				
	Data	CLK	\overline{LE}	\overline{BL}	\overline{POL}	Shift Register		High-Voltage Output		Data Out
						1	2...32	1	2...32	
All On	X	X	X	L	L	Note 2	Note 2	On	On	Note 2
All Off	X	X	X	L	H	Note 2	Note 2	Off	Off	Note 2
Invert Mode	X	X	L	H	L	Note 2	Note 2	$\overline{\text{Note 2}}$	$\overline{\text{Note 2}}$	Note 2
Load S/R	H or L	↓	L	H	H	H or L	Note 2	Note 2	Note 2	Note 2
Load Latches	X	H or L	↑	H	H	Note 2	Note 2	Note 2	Note 2	Note 2
	X	H or L	↑	H	L	Note 2	Note 2	$\overline{\text{Note 2}}$	$\overline{\text{Note 2}}$	Note 2
Transparent Latch Mode	L	↓	H	H	H	L	Note 2	Off	Note 2	Note 2
	H	↓	H	H	H	H	Note 2	On	Note 2	Note 2

Note 1: H = High logic level

L = Low logic level

X = Don't care

↓ = High-to-low transition

↑ = Low-to-high transition

2: Dependent on previous stage's state before the last CLK ↓ or last \overline{LE} high

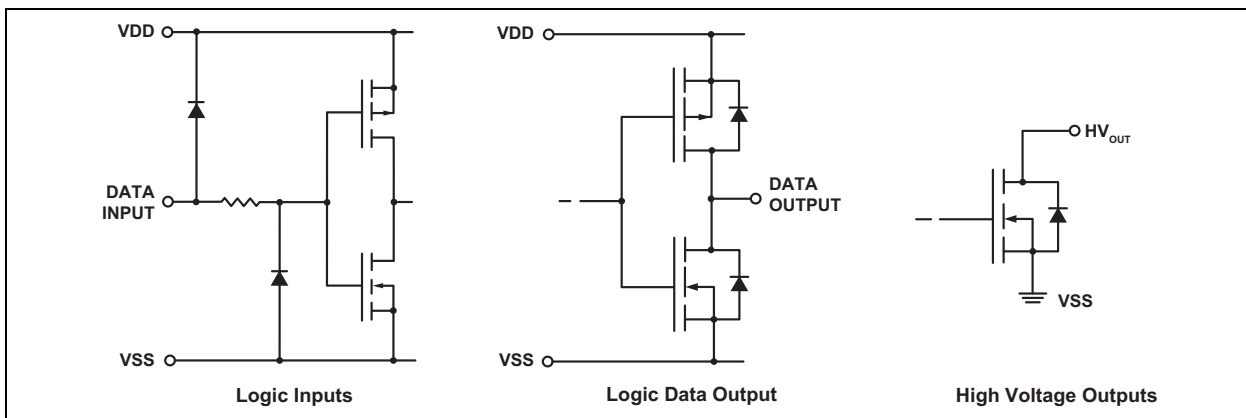
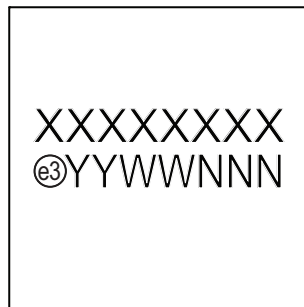

FIGURE 3-1: Input and Output Equivalent Circuits.

4.0 PACKAGE MARKING INFORMATION

4.1 Packaging Information

44-lead QFN



Example



Legend:	XX...X	Product Code or Customer-specific information
	Y	Year code (last digit of calendar year)
	YY	Year code (last 2 digits of calendar year)
	WW	Week code (week of January 1 is week '01')
	NNN	Alphanumeric traceability code
	ⓔ3	Pb-free JEDEC [®] designator for Matte Tin (Sn)
	*	This package is Pb-free. The Pb-free JEDEC designator (ⓔ3) can be found on the outer packaging for this package.
Note:	In the event the full Microchip part number cannot be marked on one line, it will be carried over to the next line, thus limiting the number of available characters for product code or customer-specific information. Package may or not include the corporate logo.	

44-Lead QFN Package Outline (K7) 7.00x7.00mm body, 0.80mm height (max), 0.50mm pitch

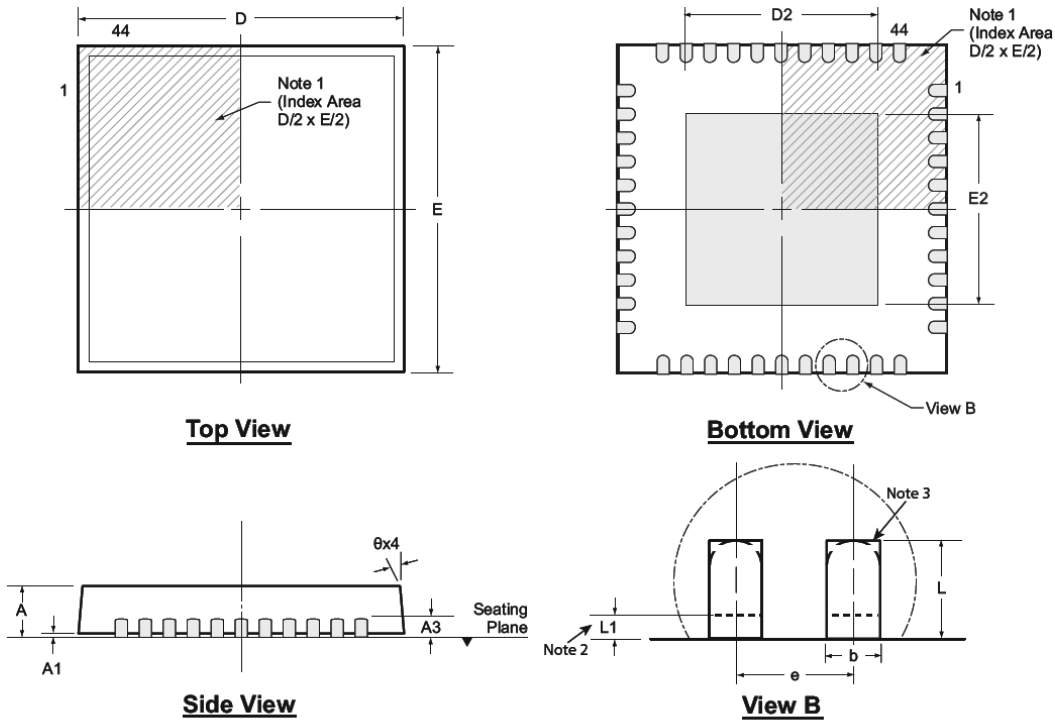

Note: For the most current package drawings, see the Microchip Packaging Specification at www.microchip.com/packaging.

Notes:

1. A Pin 1 identifier must be located in the index area indicated. The Pin 1 identifier can be: a molded mark/identifier; an embedded metal marker; or a printed indicator.
2. Depending on the method of manufacturing, a maximum of 0.15mm pullback (L1) may be present.
3. The inner tip of the lead may be either rounded or square.

Symbol	A	A1	A3	b	D	D2	E	E2	e	L	L1	θ	
Dimension (mm)	MIN	0.70	0.00	0.20 REF	0.18	6.85*	5.00†	6.85*	5.00†	0.50 BSC	0.45†	0.00	0°
	NOM	0.75	0.02		0.25	7.00	5.15†	7.00	5.15†		0.55†	-	-
	MAX	0.80	0.05		0.30	7.15*	5.25†	7.15*	5.25†		0.65†	0.15	14°

JEDEC Registration MO-220, Variation WKKD-3, Issue K, June 2006

* This dimension is not specified in the JEDEC drawing.

† This dimension differs from the JEDEC drawing.

Drawings not to scale.

APPENDIX A: REVISION HISTORY

Revision A (July 2019)

- Converted Supertex Doc# DSFP-PIC18FXXXX to Microchip DS20005702A
- Changed the quantity of the 44-lead QFN K7 package from 280/Tray to 260/Tray
- Changed the quantity of the K7 M933 media type from 2000/Reel to 3000/Reel
- Removed the HVCMOS[®] Technology from the Features section
- Made minor text changes throughout the document

HV5623

PRODUCT IDENTIFICATION SYSTEM

To order or obtain information, e.g., on pricing or delivery, contact your local Microchip representative or sales office.

<u>PART NO.</u>	<u>XX</u>	-	<u>X</u>	-	<u>X</u>
Device	Package Options		Environmental		Media Type
Device:	HV5623	=	32-Channel Serial-to-Parallel Converter with Open-Drain Outputs		
Package:	K7	=	44-lead (7x7) WQFN		
Environmental:	G	=	Lead (Pb)-free/RoHS-compliant Package		
Media Type:	(blank)	=	260/Tray for a K7 Package		
	M933	=	3000/Reel for a K7 Package		

Examples:

a) HV5623K7-G: 32-Channel Serial-to-Parallel Converter with Open-Drain Outputs, 44-lead (7x7) WQFN, 260/Tray

b) HV5623K7-G-M933: 32-Channel Serial-to-Parallel Converter with Open-Drain Outputs, 44-lead (7x7) WQFN, 3000/Reel

Note the following details of the code protection feature on Microchip devices:

- Microchip products meet the specification contained in their particular Microchip Data Sheet.
- Microchip believes that its family of products is one of the most secure families of its kind on the market today, when used in the intended manner and under normal conditions.
- There are dishonest and possibly illegal methods used to breach the code protection feature. All of these methods, to our knowledge, require using the Microchip products in a manner outside the operating specifications contained in Microchip's Data Sheets. Most likely, the person doing so is engaged in theft of intellectual property.
- Microchip is willing to work with the customer who is concerned about the integrity of their code.
- Neither Microchip nor any other semiconductor manufacturer can guarantee the security of their code. Code protection does not mean that we are guaranteeing the product as “unbreakable.”

Code protection is constantly evolving. We at Microchip are committed to continuously improving the code protection features of our products. Attempts to break Microchip's code protection feature may be a violation of the Digital Millennium Copyright Act. If such acts allow unauthorized access to your software or other copyrighted work, you may have a right to sue for relief under that Act.

Information contained in this publication regarding device applications and the like is provided only for your convenience and may be superseded by updates. It is your responsibility to ensure that your application meets with your specifications. MICROCHIP MAKES NO REPRESENTATIONS OR WARRANTIES OF ANY KIND WHETHER EXPRESS OR IMPLIED, WRITTEN OR ORAL, STATUTORY OR OTHERWISE, RELATED TO THE INFORMATION, INCLUDING BUT NOT LIMITED TO ITS CONDITION, QUALITY, PERFORMANCE, MERCHANTABILITY OR FITNESS FOR PURPOSE. Microchip disclaims all liability arising from this information and its use. Use of Microchip devices in life support and/or safety applications is entirely at the buyer's risk, and the buyer agrees to defend, indemnify and hold harmless Microchip from any and all damages, claims, suits, or expenses resulting from such use. No licenses are conveyed, implicitly or otherwise, under any Microchip intellectual property rights unless otherwise stated.

Trademarks

The Microchip name and logo, the Microchip logo, Adaptec, AnyRate, AVR, AVR logo, AVR Freaks, BesTime, BitCloud, chipKIT, chipKIT logo, CryptoMemory, CryptoRF, dsPIC, FlashFlex, flexPWR, HELDO, IGLoo, JukeBlox, KeeLoq, Klear, LANCheck, LinkMD, maXStylus, maXTouch, MediaLB, megaAVR, Microsemi, Microsemi logo, MOST, MOST logo, MPLAB, OptoLyzer, PackeTime, PIC, picoPower, PICSTART, PIC32 logo, PolarFire, Prochip Designer, QTouch, SAM-BA, SenGenuity, SpyNIC, SST, SST Logo, SuperFlash, Symmetricom, SyncServer, Tachyon, TempTrackr, TimeSource, tinyAVR, UNI/O, Vectron, and XMEGA are registered trademarks of Microchip Technology Incorporated in the U.S.A. and other countries.

APT, ClockWorks, The Embedded Control Solutions Company, EtherSynch, FlashTec, Hyper Speed Control, HyperLight Load, IntelliMOS, Libero, motorBench, mTouch, Powermite 3, Precision Edge, ProASIC, ProASIC Plus, ProASIC Plus logo, Quiet-Wire, SmartFusion, SyncWorld, Temux, TimeCesium, TimeHub, TimePictra, TimeProvider, Vite, WinPath, and ZL are registered trademarks of Microchip Technology Incorporated in the U.S.A.

Adjacent Key Suppression, AKS, Analog-for-the-Digital Age, Any Capacitor, AnyIn, AnyOut, BlueSky, BodyCom, CodeGuard, CryptoAuthentication, CryptoAutomotive, CryptoCompanion, CryptoController, dsPICDEM, dsPICDEM.net, Dynamic Average Matching, DAM, ECAN, EtherGREEN, In-Circuit Serial Programming, ICSP, INICnet, Inter-Chip Connectivity, JitterBlocker, KlearNet, KlearNet logo, memBrain, Mindi, MiWi, MPASM, MPF, MPLAB Certified logo, MPLIB, MPLINK, MultiTRAK, NetDetach, Omniscient Code Generation, PICDEM, PICDEM.net, PICkit, PICtail, PowerSmart, PureSilicon, QMatrix, REAL ICE, Ripple Blocker, SAM-ICE, Serial Quad I/O, SMART-I.S., SQI, SuperSwitcher, SuperSwitcher II, Total Endurance, TSHARC, USBCheck, VariSense, ViewSpan, WiperLock, Wireless DNA, and ZENA are trademarks of Microchip Technology Incorporated in the U.S.A. and other countries.

SQTP is a service mark of Microchip Technology Incorporated in the U.S.A.

The Adaptec logo, Frequency on Demand, Silicon Storage Technology, and Symmcom are registered trademarks of Microchip Technology Inc. in other countries.

GestIC is a registered trademark of Microchip Technology Germany II GmbH & Co. KG, a subsidiary of Microchip Technology Inc., in other countries.

All other trademarks mentioned herein are property of their respective companies.

© 2019, Microchip Technology Incorporated, All Rights Reserved.

ISBN: 978-1-5224-4791-7

For information regarding Microchip's Quality Management Systems, please visit www.microchip.com/quality.



MICROCHIP

Worldwide Sales and Service

AMERICAS

Corporate Office

2355 West Chandler Blvd.
Chandler, AZ 85224-6199

Tel: 480-792-7200

Fax: 480-792-7277

Technical Support:

[http://www.microchip.com/
support](http://www.microchip.com/support)

Web Address:

www.microchip.com

Atlanta

Duluth, GA

Tel: 678-957-9614

Fax: 678-957-1455

Austin, TX

Tel: 512-257-3370

Boston

Westborough, MA

Tel: 774-760-0087

Fax: 774-760-0088

Chicago

Itasca, IL

Tel: 630-285-0071

Fax: 630-285-0075

Dallas

Addison, TX

Tel: 972-818-7423

Fax: 972-818-2924

Detroit

Novi, MI

Tel: 248-848-4000

Houston, TX

Tel: 281-894-5983

Indianapolis

Noblesville, IN

Tel: 317-773-8323

Fax: 317-773-5453

Tel: 317-536-2380

Los Angeles

Mission Viejo, CA

Tel: 949-462-9523

Fax: 949-462-9608

Tel: 951-273-7800

Raleigh, NC

Tel: 919-844-7510

New York, NY

Tel: 631-435-6000

San Jose, CA

Tel: 408-735-9110

Tel: 408-436-4270

Canada - Toronto

Tel: 905-695-1980

Fax: 905-695-2078

ASIA/PACIFIC

Australia - Sydney

Tel: 61-2-9868-6733

China - Beijing

Tel: 86-10-8569-7000

China - Chengdu

Tel: 86-28-8665-5511

China - Chongqing

Tel: 86-23-8980-9588

China - Dongguan

Tel: 86-769-8702-9880

China - Guangzhou

Tel: 86-20-8755-8029

China - Hangzhou

Tel: 86-571-8792-8115

China - Hong Kong SAR

Tel: 852-2943-5100

China - Nanjing

Tel: 86-25-8473-2460

China - Qingdao

Tel: 86-532-8502-7355

China - Shanghai

Tel: 86-21-3326-8000

China - Shenyang

Tel: 86-24-2334-2829

China - Shenzhen

Tel: 86-755-8864-2200

China - Suzhou

Tel: 86-186-6233-1526

China - Wuhan

Tel: 86-27-5980-5300

China - Xian

Tel: 86-29-8833-7252

China - Xiamen

Tel: 86-592-2388138

China - Zhuhai

Tel: 86-756-3210040

ASIA/PACIFIC

India - Bangalore

Tel: 91-80-3090-4444

India - New Delhi

Tel: 91-11-4160-8631

India - Pune

Tel: 91-20-4121-0141

Japan - Osaka

Tel: 81-6-6152-7160

Japan - Tokyo

Tel: 81-3-6880-3770

Korea - Daegu

Tel: 82-53-744-4301

Korea - Seoul

Tel: 82-2-554-7200

Malaysia - Kuala Lumpur

Tel: 60-3-7651-7906

Malaysia - Penang

Tel: 60-4-227-8870

Philippines - Manila

Tel: 63-2-634-9065

Singapore

Tel: 65-6334-8870

Taiwan - Hsin Chu

Tel: 886-3-577-8366

Taiwan - Kaohsiung

Tel: 886-7-213-7830

Taiwan - Taipei

Tel: 886-2-2508-8600

Thailand - Bangkok

Tel: 66-2-694-1351

Vietnam - Ho Chi Minh

Tel: 84-28-5448-2100

EUROPE

Austria - Wels

Tel: 43-7242-2244-39

Fax: 43-7242-2244-393

Denmark - Copenhagen

Tel: 45-4450-2828

Fax: 45-4485-2829

Finland - Espoo

Tel: 358-9-4520-820

France - Paris

Tel: 33-1-69-53-63-20

Fax: 33-1-69-30-90-79

Germany - Garching

Tel: 49-8931-9700

Germany - Haan

Tel: 49-2129-3766400

Germany - Heilbronn

Tel: 49-7131-72400

Germany - Karlsruhe

Tel: 49-721-625370

Germany - Munich

Tel: 49-89-627-144-0

Fax: 49-89-627-144-44

Germany - Rosenheim

Tel: 49-8031-354-560

Israel - Ra'anana

Tel: 972-9-744-7705

Italy - Milan

Tel: 39-0331-742611

Fax: 39-0331-466781

Italy - Padova

Tel: 39-049-7625286

Netherlands - Drunen

Tel: 31-416-690399

Fax: 31-416-690340

Norway - Trondheim

Tel: 47-7288-4388

Poland - Warsaw

Tel: 48-22-3325737

Romania - Bucharest

Tel: 40-21-407-87-50

Spain - Madrid

Tel: 34-91-708-08-90

Fax: 34-91-708-08-91

Sweden - Gothenberg

Tel: 46-31-704-60-40

Sweden - Stockholm

Tel: 46-8-5090-4654

UK - Wokingham

Tel: 44-118-921-5800

Fax: 44-118-921-5820